

Nathan Deal
Governor



Christopher Nunn
Commissioner

MEMORANDUM

TO: Members of the State Codes Advisory Committee
Georgia Building Officials
Industrialized Buildings Manufacturers and Third Party Agencies
Interested Parties

FROM: Ted Miltiades, Director TM
Office of Construction Codes and Industrialized Buildings

DATE: August 9, 2018

SUBJECT: Notice of Intent to adopt new mandatory State Codes and Georgia Amendments,
Effective January 1, 2020

The State Codes Advisory Committee (SCAC) met on June 14, 2018. It recommended that the Department of Community Affairs (DCA) Board adopt the 2015 International Energy Conservation Code (IECC) with Georgia Amendments, the 2018 International Residential Code (IRC) with Georgia Amendments and 2018 International Building Code (IBC) with Georgia Amendments.

The Notice of Intention to Adopt, Synopsis, and proposed Georgia Amendments are available for review on the Georgia Department of Community Affairs webpage:

<https://dca.ga.gov/node/1965/documents/2033>

The proposed new mandatory State Codes and proposed Georgia Amendments will be presented to the Department of Community Affairs Board at 2 P.M. on Wednesday, November 14, 2018 at the Ogeechee Technical College, Natural Resources Building, Oak Room, 1 Joseph E Kennedy Boulevard, Statesboro, GA 30458. If approved, they will become effective January 1, 2020. If you have questions regarding the referenced documents, please contact the Construction Codes Program at 404-679-3118 or codes@dca.ga.gov.

TM/jr
cc: Rusty Haygood, DCA



NOTICE OF INTENTION TO ADOPT

- **2015 International Energy Conservation Code with Georgia Amendments**
- **2018 International Residential Code with Georgia Amendments**
- **2018 International Building Code with Georgia Amendments**

NOTICE IS HEREBY GIVEN at a meeting beginning at 2 P.M. on Wednesday, November 14, 2018, at the Ogeechee Technical College, Natural Resources Building, Oak Room, 1 Joseph E Kennedy Boulevard, Statesboro, GA 30458, the Board of Community Affairs intends to adopt the above-referenced code edition and amendments. If adopted by the Board, it is proposed the code edition and amendments identified above become effective on January 1, 2020.

The new mandatory state code and amendments to the Georgia State Minimum Standard Codes for construction are proposed for adoption under the authority granted to the Board of Community Affairs by the Official Code of Georgia Annotated (O.C.G.A.) Section 8-2-23. The proposed Georgia Amendments are available for review on the Georgia Department of Community Affairs website: <https://dca.ga.gov/node/1965/documents/2033> or by contacting the Construction Codes Program at 404-679-3118. The 2015 International Energy Conservation Code, the 2018 International Residential Code and the 2018 International Building Code along with their corresponding amendments are available for inspection at the Department of Community Affairs, 60 Executive Park South, N.E., Atlanta, Georgia 30329-2231.

In accordance with the Administrative Procedure Act, a public hearing has been scheduled for 10:00 A.M., Thursday, September 20, 2018 at the Department of Community Affairs, Room 302, 60 Executive Park South, N.E., Atlanta, Georgia 30329-2231.

Any party wishing to express views or opinions regarding the proposed new mandatory state code and proposed Georgia Amendments may do so by submitting them in writing by close of business on Tuesday, September 4, 2018 to: Ted Miltiades, Director, Office of Construction Codes, Georgia Department of Community Affairs, 60 Executive Park South, N.E., Atlanta, Georgia, 30329-2231 or by presenting them at the public hearing.

This 9th day of August, 2018.



G. Christopher Nunn, Commissioner

Sworn to and subscribed

before me this

9 day of August, 2018

**THE ADOPTED INTERNATIONAL ENERGY CONSERVATION CODE, 2015
EDITION, WITH GEORGIA AMENDMENTS, THE ADOPTED INTERNATIONAL
BUILDING CODE, 2018 EDITION, WITH GEORGIA AMENDMENTS AND THE
ADOPTED INTERNATIONAL RESIDENTIAL CODE, 2018 EDITION, WITH
GEORGIA AMENDMENTS**

SYNOPSIS OF PROPOSED RULES

If adopted by the Board of Community Affairs, the proposed rule would adopt the **INTERNATIONAL ENERGY CONSERVATION CODE, 2015 Edition**, with the following Georgia Amendments, to replace the current **INTERNATIONAL ENERGY CONSERVATION CODE, 2009 Edition**, with Georgia Amendments:

INTERNATIONAL ENERGY CONSERVATION CODE, 2015 EDITION:

- Delete Section C101.1 ‘Title’ without substitution.
- Add new Section C101.6 ‘Requirements for high-efficiency cooling towers’.
- Delete SECTION C104 ‘INSPECTIONS’ without substitution.
- Delete SECTION C107 ‘FEES’ without substitution.
- Delete SECTION C108 ‘STOP WORK ORDER’ without substitution.
- Delete SECTION C109 ‘BOARD OF APPEALS’ without substitution.
- Revise the definition for ‘COEFFICIENT OF PERFORMANCE (COP) – COOLING’.
- Delete definition of ‘CONDITIONED SPACE’ and substitute.
- Add definition of ‘COOLING TOWER’.
- Delete definition of ‘ON-SITE RENEWABLE ENERGY’, and substitute.
- Revise Table C402.1.3 ‘Opaque Thermal Envelope Insulation Component Minimum Requirements, R-Value Method^a’ *Climate Zone 4* except Marine, for unheated slabs.
- Delete Section C403.2.3 ‘HVAC equipment performance requirements’ and substitute.
- Delete Section C403.2.8 ‘Kitchen Exhaust Systems’ without substitution.
- Delete Table C403.2.8 ‘MAXIMUM NET EXHAUST FLOW RATE, CFM PER LINEAR FOOT OF HOOD LENGTH’ without substitution.
- Delete Section C403.2.9 ‘Duct and plenum insulation and sealing’ and substitute.
- Add new Section C403.2.9.2 ‘Joints, Seams and Connections’.
- Revise Section C403.3 ‘Economizers (Prescriptive)’.
- Delete Section C403.4.2.6 ‘Pump isolation’ to add a new sentence at the end.
- Delete Section C407.3 ‘Performance-based compliance’ and substitute.
- Revise Section C407.4.2 ‘Additional documentation’ to add a new item 6.
- Revise Section C408 ‘System Commissioning’.
- Delete Section C408.2.4.1 ‘Acceptance of report’.
- Revise Chapter 6 ‘Referenced Standards’.
- Delete Section R101.1 ‘Title’ without substitution.
- Delete SECTION R103 ‘CONSTRUCTION DOCUMENTS’ without substitution.
- Delete SECTION R104 ‘INSPECTIONS’ without substitution.
- Delete SECTION R107 ‘FEES’ without substitution.
- Delete SECTION R108 ‘STOP WORK ORDER’ without substitution.

- Delete SECTION R109 ‘BOARD OF APPEALS’ without substitution.
- Add definition of ‘ATTIC KNEEWALL’.
- Add new definition of ‘CERTIFIED DUCT AND ENVELOPE TIGHTNESS (DET) VERIFIER’.
- Delete definition of ‘CONDITIONED SPACE’ and substitute.
- Add definition of ‘ON-SITE RENEWABLE ENERGY’.
- Revise Section R401.2 ‘Compliance’.
- Revise Section R401.3 ‘Certificate (Mandatory)’ by revising first sentence and adding at end.
- Revise Table R402.1.2 ‘Insulation and Fenestration Requirements by Component^a’.
- Revise Table R402.1.4 ‘Equivalent *U*-Factors^a’.
- Add a new Section R402.1.6 ‘Compliance Alternative Constraints (Mandatory)’.
- Add a new Table R402.1.6, ‘Minimum Insulation *R*-Values for Envelope Components When Trade-offs Are Used’.
- Revise Section R402.2.1 ‘Ceilings with attic spaces’.
- Delete Section R402.2.3 ‘Eave baffle’ and substitute.
- Delete Section R402.2.4 ‘Access hatches and doors’ and substitute.
- Delete Section R402.2.11 ‘Crawl space walls’ and substitute.
- Revise Section R402.3.4 ‘Opaque door exemption’.
- Revise R402.4.1.1 ‘Installation’.
- Revise Section R402.4.1.2 ‘Testing’.
- Add a new Section R402.4.1.3 ‘Low-rise R-2 multifamily testing’.
- Add a new Section R402.4.1.3.1 ‘Low-rise multifamily testing protocol (Optional)’.
- Revise Section R403.1.2 ‘Heat pump supplementary heat (Mandatory)’ to add a new sentence at the end.
- Add new Section R403.1.2.3 ‘Primary heat source’.
- Revise Section R403.3.2 ‘Sealing (Mandatory)’.
- Revise Section R403.3.3 ‘Duct testing (Mandatory)’.
- Revise Section R403.3.4 ‘Duct leakage (Prescriptive)’.
- Add a new Section R403.3.6 ‘Joints, seams and Connections’.
- Revise Section R403.5.4 ‘Drain water heat recovery units’.
- Revise Section R403.6 ‘Mechanical Ventilation’.
- Revise Section R403.7 ‘Equipment sizing and efficiency rating (Mandatory)’ by adding the following sentence at the end.
- Add new Section R403.13 ‘Power attic ventilators’.
- Revise Section R406.3 ‘Energy Rating Index’.
- Delete Section R406.3.1 ‘ERI reference design’ without substitution.
- Revise Table R406.4 ‘MAXIMUM ENERGY RATING INDEX’.
- Revise Section R406.6.1 ‘Compliance software tools’.
- Delete Section R406.7 ‘Calculation software tools’ without substitution.
- Delete Section R406.7.1 ‘Minimum capabilities’ without substitution.
- Revise and rename Section R406.7.2 ‘Specific approval’.
- Revise and rename Section R406.7.3 ‘Input values’.

- Revise Section R502.1.1.2 ‘Heating and cooling systems’ to delete the exception and substitute.
- Revise Section R503.1.2 ‘Heating and cooling systems’.
- Revise Chapter 6 ‘Referenced Standards’ to add the following new Standards.
- Delete APPENDIX RA ‘RECOMMENDED PROCEDURE FOR WORST-CASE TESTING OF ATMOSPHERIC VENTING SYSTEMS UNDER R402.4 OR R405 CONDITIONS $\leq 5ACH50$ ’, entirely and substitute with new APPENDIX RA ‘AIR SEALING KEY POINTS’.
- Add new APPENDIX RC ‘THIRD PARTY VERIFICATION’.
- Add new APPENDIX RD ‘MANDATORY COMPLIANCE CERTIFICATE’.

FURTHERMORE, if adopted by the Board of Community Affairs, the proposed rule would adopt the **INTERNATIONAL BUILDING CODE, 2018 Edition**, with the following Georgia Amendments, to replace the current **INTERNATIONAL BUILDING CODE, 2012 Edition**, with Georgia Amendments:

INTERNATIONAL BUILDING CODE, 2018 EDITION:

- Add *Preface* new paragraph (c) for *International Existing Building Code* references.
- Delete Chapter 1 ‘Scope and Administration’ entirely without substitution.
- Add a new definition of ‘Elevator Door Opening Protective Device’.
- Add a new Section 308.3.3 ‘Assisted living communities’.
- Revise Section [F] 415.9.2 ‘Liquefied Petroleum Gas Facilities’.
- Revise Table 504.4 ‘Allowable Number of Stories Above Grade Plane^{a,b}’ for the Occupancy Classification ‘I-1 Condition 2’ as shown and add new footnote ‘i’.
- Revise Section 706.2 ‘Structural stability’.
- Delete Exception to Section 706.3 ‘Materials’ without substitution.
- Add new Section 713.14.1 ‘Designated floor lobbies for elevator return’.
- Revise Section [F] 903.2.8 ‘Group R’ to add exception.
- Revise Section [F] 903.2.8.1 ‘Group R-3’.
- Revise Section [F] 903.2.8.2 ‘Group R-4, Condition 1’.
- Revise Section [F] 903.2.8.4 ‘Care facilities’.
- Revise Section [F] 903.3.1.3 ‘NFPA 13D sprinkler systems’.
- Delete Section 909.21.1 ‘Pressurization requirements’ entirely and substitute.
- Delete Chapter 11 ‘Accessibility’ entirely without substitution.
- Add new Section [BS] 1404.19 ‘Installation of wall coverings’.
- Add new Section 1701.2 ‘Construction documents’.
- Add new Section 1701.3 ‘Guidelines’.
- Revise Section 1704.2 ‘Special inspections and tests’.
- Revise Section 1704.2.1 ‘Special inspector qualifications’.
- Add new Table 1704.2 ‘Minimum Special Inspector Qualifications’.
- Revise Section 1704.2.4 ‘Report Requirement’.
- Revise Section 1810.3.2.6 ‘Allowable stresses’ title.

- Revise Table 1810.3.2.6 ‘Allowable Stresses for Materials Used in Deep Foundation Elements’ title and item 4 ‘Other conditions’.
- Delete the requirements for “service sinks” from Table [P] 2902.1 ‘Minimum Number of Required Plumbing Fixtures^a’ without substitution.
- Revise Table 3001.3 ‘Elevators and Conveying Systems and Components’ under ‘STANDARDS’ for Elevators, escalators, dumbwaiters, moving walks, material lifts to add the following new standards.
- Revise Section 3002.4 ‘Elevator car to accommodate ambulance stretcher’ to add a new exception at the end of the section.
- Delete Section 3005.4 ‘Machine rooms, control rooms, machinery spaces and control spaces’ and substitute.
- Revise Section 3005.5 ‘Shunt trip’.
- Revise the title of Chapter 34 ‘Reserved’ to read as ‘Existing Buildings’ and carry forward all the provisions from Chapter 34 ‘Existing Buildings’ of the 2012 *International Building Code*.
- Add new Section 3401.7 ‘Existing system conformance’.
- Add new Section 3408.2.1 ‘Assisted living communities’.
- Revise Chapter 35 ‘Referenced Standards’ to add the following new reference standards.
- The Department of Community Affairs hereby adopts Appendix O ‘Disaster Resilient Construction’ as optional.

FURTHERMORE, if adopted by the Board of Community Affairs, the proposed rule would adopt the **INTERNATIONAL RESIDENTIAL CODE, 2018 Edition**, with the following Georgia Amendments, to replace the current **INTERNATIONAL RESIDENTIAL CODE, 2012 Edition**, with Georgia Amendments:

INTERNATIONAL RESIDENTIAL CODE FOR ONE- AND TWO-FAMILY DWELLINGS, 2018 EDITION

- Delete Chapter 1 ‘Scope and Administration’ without substitution.
- Revise Section R202 ‘Definitions’ for “[RB] Lodging House”.
- Revise Section R202 ‘Definitions’ for “[RB] Townhouse”.
- Revise Section R302.1 ‘Exterior walls’.
- Revise Section R302.2 ‘Townhouses’.
- Delete Section R302.2.1 ‘Double walls’ without substitution.
- Delete Section R302.2.2 ‘Common walls’ without substitution.
- Revise Section R302.2.6 ‘Structural independence’ to delete exception 5 without substitution.
- Revise Section R302.5.1 ‘Opening protection’.
- Revise Table R302.6 ‘DWELLING-GARAGE SEPARATION’ to add a new footnote “a”.
- Delete Section R302.13 ‘Fire protection of floors’ without substitution.
- Revise Section R303.4 ‘Mechanical ventilation’.
- Add new Section R306.5 ‘Exterior hose bibs, sill cocks or outside hydrants’.

- Add new Section R306.6 ‘Construction worker toilet facilities’.
- Delete Section R309.5 ‘Fire sprinklers’ without substitution.
- Delete Exception to Section R311.7.11 ‘Alternating tread devices’ without substitution.
- Revise the heading of Section R312 ‘Guards and Window Fall Protection’.
- Delete Section 312.2 ‘Window fall protection’ without substitution.
- Delete Section R313 ‘AUTOMATIC FIRE SPRINKLER SYSTEMS’ and substitute.
- Delete any other code references to Section P2904 ‘Dwelling unit fire sprinkler systems’ and substitute NFPA 13D.
- Revise Section R315.2.1 ‘New Construction’.
- Revise Section R321.1 ‘Elevators’ and add a new Section R321.1.1 ‘Hoistway opening framing’.
- Delete Section R322.1.9 ‘Manufactured homes’ without substitution.
- Revise Section R502.6 ‘Bearing’.
- Revise Figure R507.5.1(1) ‘DECK BEAM TO DECK POST’ to include a new illustration for “Corner Beam Over Post”.
- Revise R507.9.1.3 ‘Ledger to band joist details’.
- Revise Figure R507.9.1.3(2) ‘Placement of Lag Screws and Bolts in Band Joists’.
- Revise Figure R507.9.2(1) ‘Deck Attachment for Lateral Loads’.
- Revise Figure R507.9.2(2) ‘Deck Attachment for Lateral Loads’ and Note.
- Add new exception to R602.10 ‘Wall bracing’.
- Delete R806.5 ‘Unvented attic and unvented enclosed rafter assemblies’ Item 5.2 without substitution.
- Add new Section R807.1.1 ‘Attic service access’.
- Revise Section M1301.2 ‘Identification’.
- Delete Section M1601.1.1 ‘Above-ground duct systems’, Item 5 without substitution.
- Revise Section M1601.1.1 ‘Above ground duct systems’, Item 7.1.
- Revise Section M1901.2 ‘Cooking appliances’ to add a new exception.
- Delete Section G2415.6 (404.6) ‘Underground penetrations prohibited’ and substitute.
- Revise Section G2415.7.1 (404.7.1) ‘Piping through bored holes or notches’.
- Delete Section G2415.7.2 (404.7.2) ‘Piping installed in other locations’ without substitution.
- Delete Section G2415.11.1 (404.11.1) ‘Galvanizing’ without substitution.
- Revise Section G2415.18 (404.18) ‘Pipe Cleaning’.
- Add new Section G2420.2.1 (409.2.1) ‘System shutoff valve’.
- Delete Section G2423.1 (413.1) ‘General’ and substitute.
- Revise Appendix Q ‘Tiny Houses’.
- Add Appendix U ‘Disaster Resilient Construction’ as optional.



Georgia State Supplements and Amendments to the International Energy Conservation Code (2015 Edition)

Georgia Department of Community Affairs
Community Development Division
60 Executive Park South, N.E.
Atlanta, Georgia 30329-2231
(404) 679-3118
www.dca.ga.gov

Revised January 1, 2019

**GEORGIA STATE MINIMUM STANDARD ENERGY CODE
(INTERNATIONAL ENERGY CONSERVATION CODE
WITH GEORGIA STATE SUPPLEMENTS AND AMENDMENTS)**

The INTERNATIONAL ENERGY CONSERVATION CODE, 2015 Edition, published by the International Code Council, when used in conjunction with these Georgia State Supplements, Amendments and any other Georgia State Amendments, shall constitute the official *Georgia State Minimum Standard Energy Code*.

GEORGIA STATE SUPPLEMENTS AND AMENDMENTS

SCOPE:

Each chapter of these Georgia State Supplements and Amendments corresponds with a chapter of the *International Energy Conservation Code (IECC)*.

Commercial Provisions

- Chapter 1: Scope and Administration
- Chapter 2: Definitions
- Chapter 3: General Requirements
- Chapter 4: Commercial Energy Efficiency
 - Compliance Pathways for Commercial and High-Rise Residential Construction:
 - Any of those delineated in this chapter; or
 - *COMcheck*¹
- Chapter 5: Existing Buildings
- Chapter 6: Referenced Standards

Residential Provisions

- Chapter 1: Scope and Administration
- Chapter 2: Definitions
- Chapter 3: General Requirements
- Chapter 4: Residential Energy Efficiency
 - Compliance Pathways for Low-Rise Residential Construction:
 - Any of those delineated in this chapter; or
 - *REScheck*¹
- Chapter 5: Existing Buildings
- Chapter 6: Referenced Standards
- Appendices RA, RB, RC and RD
 - Throughout the appendices, there is information that may be helpful in meeting and understanding the *Georgia State Minimum Standard Energy Code*. In cases of conflict, refer to the *IECC* for clarification.

1. *REScheck* and *COMcheck* are computer programs developed by Pacific Northwest National Laboratories for the U.S. Department of Energy (D.O.E.) to assist in demonstration of compliance with the *IECC*. They may be obtained free of charge from the D.O.E. online at www.energycodes.gov. When following the *REScheck* compliance pathway, select the 2015 *IECC* as the code version. When following the *COMcheck* compliance pathway, select either *IECC* 2015 or *ASHRAE/IESNA Standard 90.1-2013*.

The ‘Mandatory’ requirements of the *IECC* apply to all compliance methods.

Where these Georgia State Supplements and Amendments conflict with either the *IECC* or *ANSI/ASHRAE/IES Standard 90.1*, these Georgia State Supplements and Amendments shall take precedence.

Air infiltration accounts for substantial heat loss, heat gain and moisture migration in a building. Proper sealing around all doors, windows and other envelope penetrations through the walls, ceiling and foundation is as important to code compliance as are proper insulation R-values and component U-factors.

It is not the intention of this code to abridge safety or health. Where the *IECC* and these Georgia State Supplements and Amendments conflict with other mandatory *State Minimum Standard Codes*, the *IECC* and these Georgia State Supplements and Amendments shall be enforced as written, provided that safety, health or environmental requirements of other mandatory *State Minimum Standard Codes* are not abridged.

APPENDICES:

Appendices are not enforceable unless they are specifically referenced in the body of the code or adopted by the Department of Community Affairs or the authority having jurisdiction.

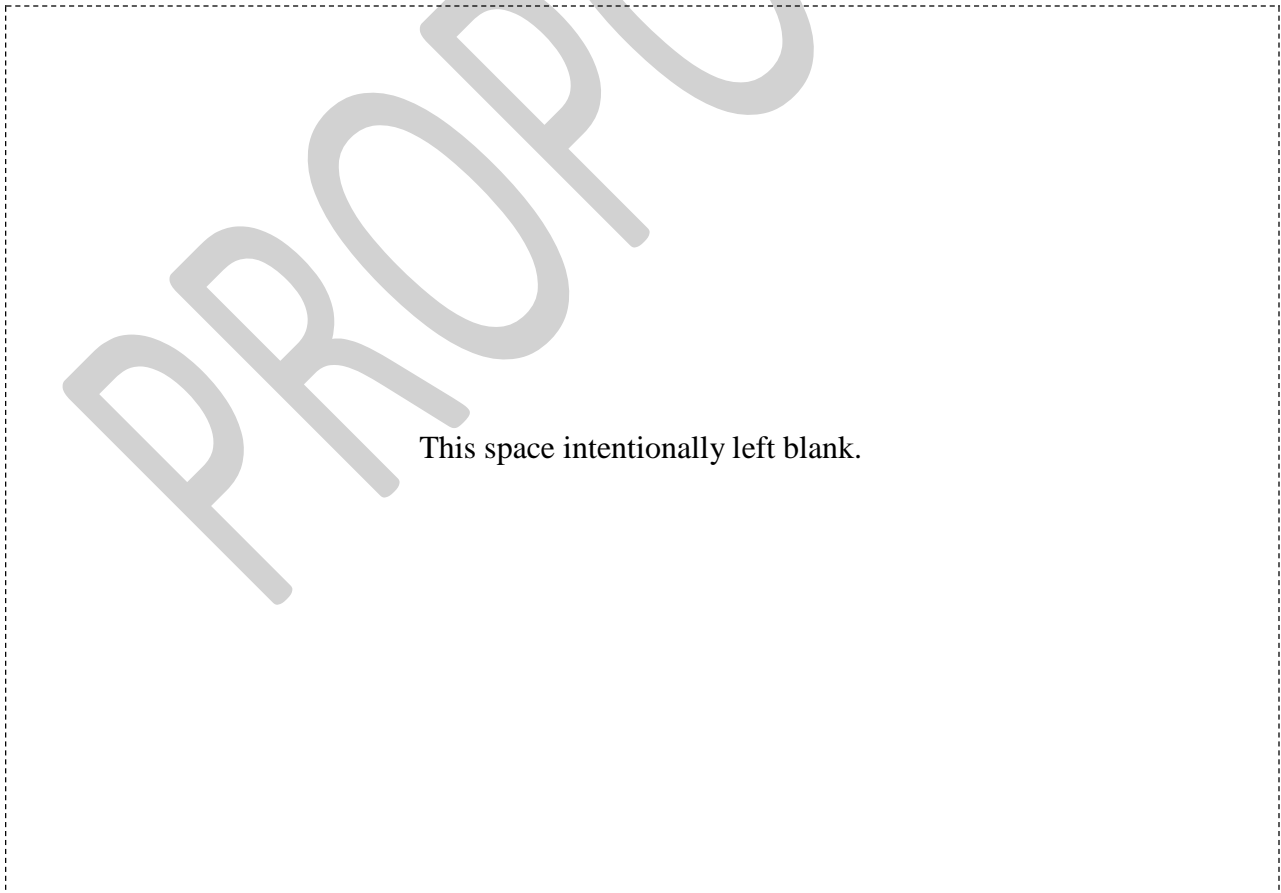

COMMERCIAL PROVISIONS

CHAPTER 1 [CE] SCOPE AND ADMINISTRATION

SECTION C101 SCOPE AND GENERAL REQUIREMENTS

*Delete Section C101.1 'Title' without substitution.
(Effective January 1, 2019)

*Add new Section C101.6 'Requirements for high-efficiency cooling towers' to read as follows:

C101.6 Requirements for high-efficiency cooling towers. Cooling towers installed in new construction shall be in compliance with ANSI/ASHRAE/IES 90.1 Standard.
(Effective January 1, 2019)

SECTION C104 INSPECTIONS

*Delete SECTION C104 'INSPECTIONS' without substitution.
(Effective January 1, 2019)

SECTION C107 FEES

*Delete SECTION C107 'FEES' without substitution.
(Effective January 1, 2019)

SECTION C108 STOP WORK ORDER

*Delete SECTION C108 'STOP WORK ORDER' without substitution.
(Effective January 1, 2019)

SECTION C109 BOARD OF APPEALS

*Delete SECTION C109 'BOARD OF APPEALS' without substitution.
(Effective January 1, 2019)

CHAPTER 2 [CE] DEFINITIONS

SECTION C202 GENERAL DEFINITIONS

*Revise the definition for ‘COEFFICIENT OF PERFORMANCE (COP) – COOLING’, to read as follows:

COEFFICIENT OF PERFORMANCE (COP) – COOLING. The ratio of the rate of heat removal to the rate of energy input, in consistent units, for a complete refrigerating system or some specific portion of that system under designated operating conditions.
(Effective January 1, 2019)

*Delete definition of ‘CONDITIONED SPACE’ and substitute the following:

SPACE. An enclosed space within a building. The classifications of spaces are as follows for the purpose of determining building envelope requirements:

(a) Conditioned space: a cooled space, heated space, or indirectly conditioned space is defined as follows:

(1) Cooled space: an enclosed space within a building that is cooled by a cooling system whose sensible output capacity exceeds 5 Btu/h·ft² of floor area.

(2) Heated space: an enclosed space within a building that is heated by a heating system whose output capacity relative to the floor area is greater than or equal to 5 Btu/h·ft².

(3) Indirectly conditioned space: an enclosed space within a building that is not a heated space or a cooled space, containing un-insulated ducts, or containing the heating equipment or which is heated or cooled indirectly by being connected to adjacent space(s), provided that air from heated or cooled spaces is transferred (naturally or mechanically) into the space. Unvented Attic Assemblies meeting the requirements of the IRC are an approved indirectly conditioned space.

(b) Semi-heated space: an enclosed space within a building that is heated by a heating system whose output capacity is greater than or equal to 3.4 Btu/h·ft² of floor area but is not a conditioned space.

(c) Unconditioned space: an enclosed space within a building that is not a conditioned space or a semi-heated space. Crawl spaces, attics, and parking garages with natural or mechanical ventilation are not considered enclosed spaces.

(Effective January 1, 2019)

*Add definition of ‘COOLING TOWER’ to read as follows:

COOLING TOWER. A building heat removal device used to transfer process waste heat to the atmosphere.

(Effective January 1, 2019)

* Delete definition of ‘ON-SITE RENEWABLE ENERGY’, and substitute the following:

ON-SITE RENEWABLE ENERGY. Energy systems that are located on the building site, are installed on the building’s side of the utility service provider’s meter, produce energy primarily intended for use in the building and not solely for export to utilities, and produce energy derived from any of the following sources: solar radiation, wind, waves, tides, biogas, biomass or the internal heat of the earth. Energy systems that derive energy from solar radiation shall be modeled in the orientation of the energy system.

The following description only pertains to energy systems that derive energy from solar radiation and are owned by a third-party. The Georgia Solar Power Free-Market Financing Act of 2015 (commonly referred to as “HB 57”) allows a customer to purchase solar electricity generated by a solar system owned by a third-party so long as certain criteria are met. Two key criteria are that the law only authorizes solar systems that generate electricity fueled by sunlight and that the solar system must be installed on property owned or occupied by the entity purchasing the system’s electricity. The definition of “property” extends to all adjacent contiguous tracts of land utilized by the entity purchasing the solar system’s electricity. “Building Site” in C202 is defined as a contiguous area of land that is under the ownership or control of one entity. While this definition of “building site” is similar to HB 57’s definition of “property,” the key difference is that HB 57 focuses on the entity purchasing the solar system’s electricity. When modeling a solar system that is owned by a third-party, it is best to refer to HB 57 to determine whether all criteria have been met.

(Effective January 1, 2019)

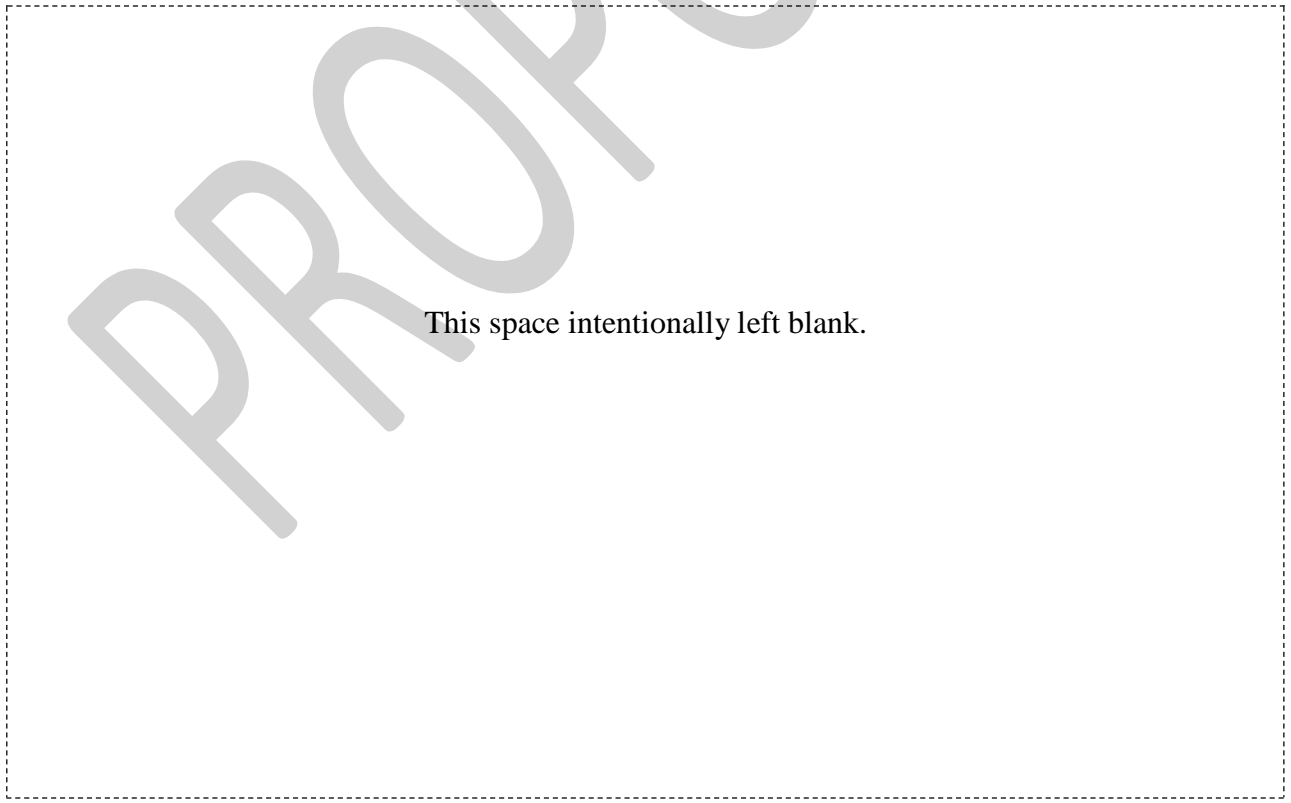

**CHAPTER 4 [CE] COMMERCIAL
ENERGY EFFICIENCY**

**SECTION C402
BUILDING ENVELOPE REQUIREMENTS**

*Revise Table C402.1.3 ‘Opaque Thermal Envelope Insulation Component Minimum Requirements, R-Value Method^a’ *Climate Zone* 4 except Marine, for unheated slabs to read as follows:

TABLE C402.1.3 OPAQUE THERMAL ENVELOPE INSULATION COMPONENT MINIMUM REQUIREMENTS, R- VALUE METHOD^a		
Climate Zone	4 EXCEPT MARINE	
	All other	Group R
	Slab-on-grade floors	
Unheated slabs	NR	NR

(remainder of table left unchanged)

(Effective January 1, 2019)

**SECTION C403
BUILDING MECHANICAL SYSTEMS**

*Delete Section C403.2.3 ‘HVAC equipment performance requirements’ and substitute to read as follows:

C403.2.3 HVAC equipment performance requirements. Equipment shall meet the minimum efficiency requirements of Tables 6.8.1-1, 6.8.1-2, 6.8.1-3, 6.8.1-4, 6.8.1-5, 6.8.1-6, 6.8.1-7, 6.8.1-9, 6.8.1-10, 6.8.1-11, 6.8.1-12, and 6.8.1-13 of ASHRAE Standard 90.1 when tested and rated in accordance with the applicable test procedure. Plate-type liquid-to-liquid heat exchangers shall meet the minimum requirements of Table 6.8.1-8 of ASHRAE Standard 90.1. The efficiency shall be verified through certification under an *approved* certification program or, where a certification program does not exist, the equipment efficiency ratings shall be supported by data furnished by the manufacturer. Where multiple rating conditions or performance requirements are provided, the equipment shall satisfy all stated requirements. Where components, such as indoor or outdoor coils, from different manufacturers are used, calculations and supporting data shall be furnished by the designer that demonstrates that the combined efficiency of the specified components meets the requirements herein.

The above referenced tables of ASHRAE 90.1, HVAC equipment performance tables are available to download for free from DCA’s webpage located at: <https://dca.ga.gov/node/3522/documents/2085> (Effective January 1, 2019)

*Delete Section C403.2.8 'Kitchen Exhaust Systems' without substitution.
(Effective January 1, 2019)

*Delete Table C403.2.8 'MAXIMUM NET EXHAUST FLOW RATE, CFM PER LINEAR FOOT OF HOOD LENGTH' without substitution.
(Effective January 1, 2019)

*Delete Section C403.2.9 'Duct and plenum insulation and sealing' and substitute to read as follows:

C403.2.9 Duct and plenum insulation and sealing. Supply and return air ducts and plenums shall be insulated with a minimum of R-6 insulation where located in unconditioned spaces and where located outside the building with a minimum of R-8 insulation in *Climate Zones 2 through 4*. Where located within a building envelope assembly, the duct or plenum shall be separated from the building exterior or unconditioned or exempt spaces by a minimum of R-8 insulation in *Climate Zones 2 through 4*.

Exceptions:

1. Where located within equipment.
2. Where the design temperature difference between the interior and exterior of the duct or plenum is not greater than 15°F (8°C).

Ducts, air handlers and filter boxes shall be sealed. Joints and seams shall comply with section C403.2.9.2 of these Georgia State Supplements and Amendments.

Exceptions:

1. Air-impermeable spray foam product shall be permitted to be applied without additional joint seals.
2. For ducts having a static pressure classification of less than 2 inches of water column (500 Pa), additional closure systems shall not be required for continuously welded joints and seams, and locking-type joints and seams of other than the snap-lock and button-lock types.
3. Where a duct connection is made that is partially inaccessible, three screws or rivets shall be equally spaced on the exposed portion of the joint so as to prevent a hinge effect.
4. Sealing that would void product listings is not required.

(Effective January 1, 2019)

*Add new Section C403.2.9.2 'Joints, Seams and Connections' to read as follows:

C403.2.9.2 Joints, Seams and Connections. All longitudinal and transverse joints, seams and connections in metallic and nonmetallic ducts shall be constructed as specified in *SMACNA HVAC Duct Construction Standards- Metal and Flexible* and *NAIMA Fibrous Glass Duct Construction Standards*. All joints, longitudinal and transverse seams, and connections in ductwork shall be securely fastened and sealed with welds, gaskets, mastics (adhesives), mastic-plus-embedded-fabric systems or tapes. Without exception all closure systems shall have mastic applied that is at least 0.08 inches (2 mm) thick.

Closure systems used to seal flexible air ducts and flexible air connections shall comply with UL 181B and shall be marked “181B-FX” for pressure-sensitive tape or “181B-M” for mastic. Duct connections to flanges of air distribution systems equipment shall be sealed and mechanically fastened. Mechanical fasteners for use with flexible non-metallic air ducts shall comply with UL 181B and shall be marked 181B-C. Crimp joints for round metallic ducts shall have a contact lap of not less than 1 inch (25.4 mm) and shall be mechanically fastened by means of not less than three sheet-metal screws or rivets equally spaced around the joint.

Closure systems used to seal metal ductwork shall be installed in accordance with manufacturer’s instructions. Round metallic ducts shall be mechanically fastened by means of at least three sheet metal screws or rivets spaced equally around the joint. Unlisted duct tape shall not be permitted as a sealant on any duct.

Exceptions:

1. Spray polyurethane foam shall be permitted to be applied without additional joint seals.
2. Where a duct connection is made that is partially inaccessible, three screws or rivets shall be equally spaced on the exposed portion of the joint so as to prevent a hinge effect.
3. Continuously welded and locking-type longitudinal joints and seams in ducts operating at static pressure less than 2 inches (51 mm) of water column (500 Pa) pressure classification shall not require additional closure systems.

(Effective January 1, 2019)

*Revise Section C403.3 ‘Economizers (Prescriptive)’ to read as follows:

C403.3 Economizers (Prescriptive).

Revise Section C403.3, Economizers (Prescriptive), to delete the last sentence of exception 2 and add exception number 10, Computer Room Applications, at the end.

10. Computer Room Applications

(Effective January 1, 2019)

*Delete Section C403.4.2.6 ‘Pump isolation’ to add a new sentence at the end to read as follows:

C403.4.2.6 Pump isolation. Chilled water plants including more than one chiller shall have the capability to reduce flow automatically through the chiller plant when a chiller is shut down. Chillers piped in series for the purpose of increased temperature differential shall be considered as one chiller.

Boiler plants including more than one boiler shall have the capability to reduce flow automatically through the boiler plant when a boiler is shut down. Flow isolation shall allow time for adequate thermal dissipation of residual heat to prevent relief before isolating boiler(s). (Effective January 1, 2019)

**SECTION C407
TOTAL BUILDING PERFORMANCE**

*Delete Section C407.3 ‘Performance-based compliance’ and substitute to read as follows:

C407.3 Performance-based compliance. Compliance based on total building performance requires that a proposed building (*proposed design*) be shown to have an annual energy cost that is less than or equal to the annual energy cost of the *standard reference design*. Energy prices shall be taken from a source *approved* by the *code official*, such as the Department of Energy, Energy Information Administration's *State Energy Price and Expenditure Report*. *Code officials* shall be permitted to require time-of-use pricing in energy cost calculations. The reduction in annual energy cost of the *proposed design* associated with *on-site renewable energy* shall be not more than 5% of the total annual energy cost. The amount of renewable energy purchased from off-site sources shall be the same in the *standard reference design* and the *proposed design*.

Exception: Jurisdictions that require site energy (1 kWh = 3413 Btu) rather than energy cost as the metric of comparison.

(Effective January 1, 2019)

*Revise Section C407.4.2 ‘Additional documentation’ to add a new item 6 to read as follows:

C407.4.2 Additional documentation.

6. Documentation of the reduction in annual energy use associated with on-site renewable energy.

**SECTION C408
SYSTEM COMMISSIONING**

*Revise Section C408 ‘System Commissioning’ to read as follows:

Strike the words “commission” and “commissioning” wherever they appear and replace with “functional performance testing” throughout the entire Section C408 SYSTEM COMMISSIONING as required.

(Effective January 1, 2019)

*Delete Section C408.2.4.1 ‘Acceptance of report’ without substitution.

(Effective January 1, 2019)

**CHAPTER 6 [CE]
REFERENCED STANDARDS**

*Revise Chapter 6 ‘Referenced Standards’ to add the following new Standards to read as follows:

UL UL LLC
 333 Pfingsten Road
 Northbrook, IL 60062-2096

Standard reference number	Title	Referenced in code section number
181—2013	Factory-made Air Ducts and Air Connectors—with Revisions through May 2003	C403.2.9.2
181A—2013	Closure Systems for Use with Rigid Air Ducts and Air Connectors—with Revisions through December 1998.....	C403.2.9.2
181B—2013	Closure Systems for Use with Flexible Air Ducts and Air Connectors—with Revisions through August 2003.....	C403.2.9.2

(Standards not listed to remain unchanged)

This space intentionally left blank.

RESIDENTIAL PROVISIONS

**CHAPTER 1 [RE]
SCOPE AND ADMINISTRATION**

**SECTION R101
SCOPE AND GENERAL REQUIREMENTS**

*Delete Section R101.1 'Title' without substitution.
(Effective January 1, 2019)

**SECTION R103
CONSTRUCTION DOCUMENTS**

*Delete SECTION R103 'CONSTRUCTION DOCUMENTS' without substitution.
(Effective January 1, 2019)

**SECTION R104
INSPECTIONS**

*Delete SECTION R104 'INSPECTIONS' without substitution.
(Effective January 1, 2019)

**SECTION R107
FEES**

*Delete SECTION R107 'FEES' without substitution.
(Effective January 1, 2019)

**SECTION R108
STOP WORK ORDER**

*Delete SECTION R108 'STOP WORK ORDER' without substitution.
(Effective January 1, 2019)

**SECTION R109
BOARD OF APPEALS**

*Delete SECTION R109 'BOARD OF APPEALS' without substitution.
(Effective January 1, 2019)

CHAPTER 2 [RE] DEFINITIONS

*Add definition of 'ATTIC KNEEWALL' to read as follows:

ATTIC KNEEWALL. Any vertical or near-vertical wall in the building envelope that has conditioned space on one side and unconditioned attic space on the other side. If the envelope features the insulation installed along the sloped ceiling, the vertical wall is considered an interior wall and thus does not require insulation.
(Effective January 1, 2019)

*Add new definition of 'CERTIFIED DUCT AND ENVELOPE TIGHTNESS (DET) VERIFIER' to read as follows:

CERTIFIED DUCT AND ENVELOPE TIGHTNESS (DET) VERIFIER. A certified DET verifier shall be a certified Home Energy Rating Systems (HERS) rater, or be a Building Performance Institute (BPI) Analyst, or be an Infiltration Duct Leakage (IDL) Certified, or successfully complete a certified DET verifier course that is approved by the Georgia Department of Community Affairs.
(Effective January 1, 2019)

*Delete definition of 'CONDITIONED SPACE' and substitute to read as follows:

SPACE. An enclosed space within a building. The classifications of spaces are as follows for the purpose of determining building envelope requirements:

(a) Conditioned space: a cooled space, heated space, or indirectly conditioned space is defined as follows:

(1) Cooled space: an enclosed space within a building that is cooled by a cooling system whose sensible output capacity exceeds 5 Btu/h·ft² of floor area.

(2) Heated space: an enclosed space within a building that is heated by a heating system whose output capacity relative to the floor area is greater than or equal to 5 Btu/h·ft².

(3) Indirectly conditioned space: an enclosed space within a building that is not a heated space or a cooled space, containing un-insulated ducts, or containing the heating equipment or which is heated or cooled indirectly by being connected to adjacent space(s), provided that air from heated or cooled spaces is transferred (naturally or mechanically) into the space. Unvented Attic Assemblies meeting the requirements of the IRC are an approved indirectly conditioned space.

(b) Semi-heated space: an enclosed space within a building that is heated by a heating system whose output capacity is greater than or equal to 3.4 Btu/h·ft² of floor area but is not a conditioned space.

(c) Unconditioned space: an enclosed space within a building that is not a conditioned space or a semi-heated space. Crawl spaces, attics, and parking garages with natural or mechanical ventilation are not considered enclosed spaces.

(Effective January 1, 2019)

* Add definition of 'ON-SITE RENEWABLE ENERGY' to read as follows:

ON-SITE RENEWABLE ENERGY. Energy systems that are located on the building site, are installed on the building's side of the utility service provider's meter, produce energy primarily intended for use in the building and not solely for export to utilities, and produce energy derived from any of the following sources: solar radiation, wind, waves, tides, biogas, biomass or the internal heat of the earth. Energy systems that derive energy from solar radiation shall be modeled in the orientation of the energy system.

The following description only pertains to energy systems that derive energy from solar radiation and are owned by a third-party. The Georgia Solar Power Free-Market Financing Act of 2015 (commonly referred to as "HB 57") allows a customer to purchase solar electricity generated by a solar system owned by a third-party so long as certain criteria are met. Two key criteria are that the law only authorizes solar systems that generate electricity fueled by sunlight and that the solar system must be installed on property owned or occupied by the entity purchasing the system's electricity. The definition of "property" extends to all adjacent contiguous tracts of land utilized by the entity purchasing the solar system's electricity. "Building Site" in R202 is defined as a contiguous area of land that is under the ownership or control of one entity. While this definition of "building site" is similar to HB 57's definition of "property," the key difference is that HB 57 focuses on the entity purchasing the solar system's electricity. When modeling a solar system that is owned by a third-party, it is best to refer to HB 57 to determine whether all criteria have been met.

(Effective January 1, 2019)

**CHAPTER 4 [RE] RESIDENTIAL
ENERGY EFFICIENCY**

**SECTION R401
GENERAL**

*Revise Section R401.2 ‘Compliance’ to read as follows:

R401.2 Compliance. Projects shall comply with all provisions of Chapter 4 labeled “Mandatory” and one of the following:

1. Sections R401 through R404.
2. Section R405.
3. Section R406.
4. The most recent version of REScheck, keyed to the 2015 IECC.

*Revise Section R401.3 ‘Certificate (Mandatory)’ by revising first sentence and adding at end as follows:

R401.3 Certificate (Mandatory). A permanent certificate shall be completed by the builder or registered design professional and posted on or near the electrical distribution panel or air handler. Where located on ...

(Middle of section left unchanged) ... water heating equipment. Refer to Appendix RD for the Mandatory Compliance Certificate that shall be used. (Remainder of section left unchanged) (Effective January 1, 2019)

The above referenced form, Mandatory Compliance Certificate is available to download for free from DCA’s webpage located at: <https://dca.ga.gov/node/3522/documents/2090>

**SECTION R402
BUILDING THERMAL ENVELOPE**

*Revise Table R402.1.2 ‘Insulation and Fenestration Requirements by Component^a’ as follows:

TABLE R402.1.2 INSULATION AND FENESTRATION REQUIREMENTS BY COMPONENT^a											
Climate Zone	Fenestration U-Factor ^b	Skylight ^b U-Factor	Glazed Fenestration SHGC ^{b,e}	Ceiling R-Value	Wood Frame Wall R-Value	Attic Kneewall R-Value ⁱ	Mass Wall R-Value	Floor R-Value	Basement ^c Wall R-Value	Slab ^d R-Value & Depth	Crawl Space ^c Wall R-Value
2	0.35	0.65	0.27	38	13	18	4/6	13	0	0	0
3	0.35	0.55	0.27	38	13	18	8/13	19	5/13 ^f	0	5/13
4 except marine	0.35	0.55	0.27	38	13	18	8/13	19	10/13	0	10/13

(Remainder of footnotes left unchanged) (Effective January 1, 2019)

*Revise Table R402.1.4 ‘Equivalent *U*-Factors^a’ as follows:

TABLE R402.1.4 EQUIVALENT <i>U</i> -FACTORS ^a								
Climate Zone	Fenestration <i>U</i> -Factor	Skylight <i>U</i> -Factor	Ceiling <i>U</i> -Factor	Frame Wall <i>U</i> -Factor	Mass Wall <i>U</i> -Factor ^b	Floor <i>U</i> -Factor	Basement Wall <i>U</i> -Factor	Crawl Space Wall <i>U</i> -Factor
2	0.35	0.65	0.030	0.084	0.165	0.064	0.360	0.477
3	0.35	0.55	0.030	0.084	0.098	0.047	0.091 ^c	0.136
4 except marine	0.35	0.55	0.030	0.084	0.098	0.047	0.059	0.065

Table footnote left unchanged
(Effective January 1, 2019)

*Add a new Section R402.1.6 ‘Compliance Alternative Constraints (Mandatory)’ to read as follows:

R402.1.6 Compliance Alternative Constraints. (Mandatory) Where Compliance Alternative Pathways are used, the minimum R-values, maximum U-factors, and maximum SHGCs for thermal envelope components in projects complying under this code (including the use of REScheck) shall be according to Table 402.1.6. Compliance Alternative Pathways include Total UA Alternative, Simulated Performance Alternative, and Energy Rating Index Alternative.

*Add a new Table R402.1.6, ‘Minimum Insulation R-Values for Envelope Components When Trade-offs Are Used’ to read as follows:

Table R402.1.6 MINIMUM INSULATION R-VALUES FOR ENVELOPE COMPONENTS WHEN TRADE-OFFS ARE USED										
Climate Zone	Wood ^a Framed Walls	Mass ^{a, b} Wall	Attic ^{a, c} Kneewall	Basement ^a Wall	Crawl ^a Wall	Floor Over Unheated Spaces	Ceilings with Attic Space	Vaulted ^{c, d} Unvented Attic Roofline Air-impermeable	Vaulted ^{c, d} Unvented Attic Roofline Air-permeable	Cathedralized ^{c, d} Vented Ceiling Roofline Air-permeable
2	13	4	18	0	0	13	30	20	20+5*	20
3	13	5	18	5	5	13	30	20	20+5*	20
4	13	5	18	5	5	13	30	20	20+15*	20
Window <i>U</i> -Factor 0.5 max with SHGC 0.30 max								* Air -impermeable as per IRC 806.5		
<p>a: Weather-stripped hinged vertical doors (minimum R-5 insulation or maximum U-0.20), weather-stripped hatches/scuttle hole covers (minimum R-19 insulation or maximum U-0.05), or weather-stripped and disappearing/ pull-down stairs (minimum R-5 insulation or maximum U-0.20) shall be deemed to meet the minimum insulation R-values of the corresponding envelope element.</p> <p>b: Any mass wall (masonry, CMU, etc.)</p> <p>c: Attic kneewall for the purpose of this code is defined as any vertical or near vertical wall in the building envelope that has conditioned space on one side and attic space on the other side.</p> <p>Exception: When the building roofline is insulated, the former kneewall is classified as an interior wall.</p> <p>d: Examples of air-impermeable insulation include spray foam and rigid foam board. Examples of air-permeable insulation include fiberglass batts and cellulose. See ‘Roofline Installed Insulation Options’ in Appendix RA, of these Georgia State Supplements and Amendments for details.</p>										

(Effective January 1, 2019)

*Revise Section R402.2.1 ‘Ceilings with attic spaces’ to read as follows:

R402.2.1 Ceilings with attic spaces. Where Section R402.1.2 would require R-38 insulation in the ceiling, installing R-30 over 100 percent of the ceiling area requiring insulation shall be deemed to satisfy the requirement for R-38 wherever the full height of uncompressed R-30 insulation extends completely over the wall top plate at the eaves.

This reduction shall not apply to the U-factor alternative approach in Section R402.1.4 and the total UA alternative in Section R402.1.5.

For HVAC attic platforms used for locating and servicing equipment, R-19 (maximum *U*-Factor 0.047) shall be deemed to meet the requirements of R-38 (maximum *U*-Factor 0.027) in the ceiling. R-19 is deemed acceptable for up to 32 square feet of attic decking per HVAC system. R-19 shall be deemed acceptable for a maximum 32 inch wide passage to the HVAC system as referenced under M1305.1.3 of the International Residential Code.
(Effective January 1, 2019)

*Delete Section R402.2.3 ‘Eave baffle’ and substitute to read as follows:

R402.2.3 Eave baffle. For air permeable insulation in vented attics, baffles shall be installed adjacent to soffit and eave vents. A minimum of a 1-inch of space shall be provided between the insulation and the roof sheathing and at the location of the vent. The baffle shall extend over the top of the insulation inward until it is at least 4 inches vertically above the top of the insulation. Any solid material such as cardboard or thin insulating sheathing shall be permissible as the baffle. (See Appendix RA for further clarification.)

(Effective January 1, 2019)

*Delete Section R402.2.4 ‘Access hatches and doors’ and substitute to read as follows:

R402.2.4 Access hatches and doors. Access doors from conditioned spaces to unconditioned spaces (e.g. attics, unconditioned basements and crawl spaces) shall be weather-stripped and insulated in accordance with the following insulation values:

1. Hinged vertical doors shall have a maximum *U*-Factor of U-0.20 (R-5 minimum);
2. Hatches/scuttle hole covers shall have a maximum *U*-Factor of U-0.05 (R-19 minimum);
and
3. Pull down stairs shall have a maximum *U*-Factor of U-0.20 with a minimum of 75 percent of the panel area having (R-5 minimum) insulation.

Access shall be provided to all equipment which prevents damaging or compressing the insulation. A wood framed or equivalent baffle or retainer is required to be provided when loose fill insulation is installed, the purpose of which is to prevent the loose fill insulation from spilling into the living space when the attic access is opened, and to provide a permanent means of maintaining the installed *R*-value of the loose fill insulation.

(Effective January 1, 2019)

*Delete Section R402.2.11 ‘Crawl space walls’ and substitute to read as follows:

R402.2.11 Crawl space walls. As an alternative to insulating floors over crawl spaces, crawl space walls shall be permitted to be insulated when the crawl space is not vented to the outside. Crawl space wall insulation shall be permanently fastened to the wall and extend downward from the floor to within 9 inches (229 mm) of the finished interior grade adjacent to the foundation wall. A 3-inch (76 mm) inspection/view strip immediately below the floor joists shall be provided to permit inspections for termites. Exposed earth in unvented crawl space foundations shall be covered with a continuous Class 1 vapor retarder in accordance with the *International Building Code*. All joints of the vapor retarder shall overlap by 6 inches (152 mm) and be sealed or taped. The edges of the vapor retarder shall extend at least 6 inches (152 mm) up the stem wall and shall be attached and sealed to the stem wall.
(Effective January 1, 2019)

*Revise Section R402.3.4 ‘Opaque door exemption’ to read as follows:

R402.3.4 Opaque door exemption. One side-hinged opaque door assembly up to 24 square feet (2.22 m²) in area is exempted from the *U*-factor requirement in Section R402.1.4. This exemption shall not apply to Attic Access Doors or the *U*-factor alternative approach in Section R402.1.4 and the total UA alternative in Section R402.1.5.
(Effective January 1, 2019)

*Revise R402.4.1.1 ‘Installation’ to read as follows:

R402.4.1.1 Installation. The components of the building thermal envelope shall be installed in accordance with the manufacturer’s instructions and the criteria listed on page 1 of Appendix RA of the 2019 Georgia State Supplements and Amendments, as applicable to the method of construction. Where required by the *code official*, an *approved* third party shall inspect all components and verify compliance. See Appendix RA ‘AIR BARRIER AND INSULATION INSTALLATION COMPONENT GUIDE’ of these Georgia State Supplements and Amendments for a graphical representation of the items listed above.
(Effective January 1, 2019)

*Revise Section R402.4.1.2 ‘Testing’ to read as follows:

R402.4.1.2 Testing. All one and two-family dwelling units shall be tested and verified to less than five air changes per hour at 50 Pascals (ACH50) for Climate Zones 2, 3, and 4. Testing shall be conducted in accordance with ASTM E 779 or ASTM E 1827 or ANSI/RESNET/ICC 380 and reported at a pressure of 0.2 inch w.g. (50 Pascals). A written report of the results of the test shall be signed by the party conducting the test and provided to the *code official*. Testing shall be performed at any time after creation of all penetrations of the *building thermal envelope*. Testing shall be conducted by a *certified duct and envelope tightness (DET) verifier*.
(Remainder of section left unchanged)
(Effective January 1, 2019)

*Add a new Section R402.4.1.3 ‘Low-rise R-2 multifamily testing’ to read as follows:

R402.4.1.3 Low-rise R-2 multifamily testing. Low-rise R-2 multifamily dwellings shall be tested to less than 7 air changes per hour at 50 Pascals (ACH50).

As an alternative to ACH50, compliance for Low-rise R-2 dwellings may be attained by achieving an Envelope Leakage Ratio at 50 Pascals (ELR50) of less than 0.35 ($ELR50 < 0.35$, where $ELR50 = CFM50 / \text{Envelope Shell Area}$, in square feet).
(Effective January 1, 2019)

*Add a new Section R402.4.1.3.1 ‘Low-rise multifamily testing protocol (Optional)’ to read as follows:

R402.4.1.3.1 Low-rise multifamily testing protocol (Optional). Where a residential building is classified as R-2, envelope testing may (optionally) employ either one or both of the following testing protocols:

1. Utilize multiple fans in adjacent units (commonly referred to as Guarded Blower Door testing) to minimize effect of leakage to adjacent units (not required).
2. Envelope testing of less than 100 percent shall be acceptable assuming a maximum sampling protocol of 1 in 4 units per floor (if sampled unit passes, the remaining up to three units are deemed to comply; if sampled unit fails, it must be sealed and retested and the remaining up to three units shall also be tested).

(Effective January 1, 2019)

SECTION R403 SYSTEMS

*Revise Section R403.1.2 ‘Heat pump supplementary heat (Mandatory)’ to add a new sentence at the end to read as follows:

R403.1.2 Heat pump supplementary heat (Mandatory). Heat pumps having supplementary electric-resistance heat shall have controls that, except during defrost, prevent supplemental heat operation when the heat pump compressor can meet the heating load. Except in emergency heating mode, the supplementary electric-resistance heat in heat pump systems installed in new construction may not energize unless the outdoor temperature is below 40° F (4°C).

(Effective January 1, 2019)

*Add new Section R403.1.2.3 ‘Primary heat source’ to read as follows:

R403.1.2.3 Primary heat source. For new dwelling unit central HVAC systems, or replacement HVAC systems installed in dwelling units that were originally permitted after January 1, 1996, electric-resistance heat shall not be used as the primary heat source. Primary heat source is defined as the heat source for the original dwelling unit system.

(Effective January 1, 2019)

*Revise Section R403.3.2 ‘Sealing (Mandatory)’ to read as follows:

R403.3.2 Sealing (Mandatory). Ducts, air handlers and filter boxes shall be sealed. Joints and seams shall comply with Section R403.3.6 of these Georgia State Supplements and Amendments.

Exceptions:

1. Air-impermeable spray foam product shall be permitted to be applied without additional joint seals.
2. For ducts having a static pressure classification of less than 2 inches of water column (500 Pa), additional closure systems shall not be required for continuously welded joints and seams, and locking-type joints and seams of other than the snap-lock and button-lock types.
3. Where a duct connection is made that is partially inaccessible, three screws or rivets shall be equally spaced on the exposed portion of the joint so as to prevent a hinge effect.
4. Sealing that would void product listings is not required.

*Revise Section R403.3.3 ‘Duct testing (Mandatory)’ to read as follows:

R403.3.3 Duct testing (Mandatory). Ducts shall be pressure tested to determine air leakage by one of the following methods:

1. Rough-in test: Total leakage shall be measured with a pressure differential of 0.1 inch w.g. (25 Pa) across the system, including the manufacturer’s air handler enclosure. All registers shall be taped or otherwise sealed during the test.
2. Post-construction test: Total leakage shall be measured with a pressure differential of 0.1 inch w.g. (25 Pa) across the entire system, including the manufacturer’s air handler enclosure. Registers shall be taped or otherwise sealed during the test.

Exceptions:

1. A duct air leakage test shall not be required where the ducts and air handlers are located entirely within the building thermal envelope.
2. Duct tightness testing is not required for existing duct systems unless more than 50% of the duct system is modified.
3. If the air handler, furnace or evaporator coil is replaced on an existing system, all joints, seams and connections from equipment to duct system and duct system connections to plenums within 5 feet from the new work shall meet the sealing requirements of this code and be verified by a visual inspection by the state licensed conditioned air contractor or by a DET Verifier.

A report of the results of the test shall be signed by the party conducting the test and provided to the owner or the owner’s agent and, if requested, to the *code official*.
(Effective January 1, 2019)

*Revise Section R403.3.4 ‘Duct leakage (Prescriptive)’ to read as follows:

R403.3.4 Duct leakage (Mandatory). The total leakage of the ducts, where measured by one of the following methods in accordance with Section R403.3.3 shall be as follows:

1. Rough-in test: The total leakage shall be less than or equal to 6 cubic feet per minute (113.3 L/min) per 100 square feet (9.29 m²) of conditioned floor area where the air handler is installed at the time of the test.
2. Post-construction test: Total leakage shall be less than or equal to 6 cubic feet per minute (113.3 L/min) per 100 sq. feet (9.29 m²) of conditioned floor area.

Exceptions:

1. A duct air leakage test shall not be required where the ducts and air handlers are located entirely within the building thermal envelope.
2. Duct tightness testing is not required for existing duct systems unless more than 50% of the duct system is modified.
3. If the air handler, furnace or evaporator coil is replaced on an existing system, all joints, seams and connections from equipment to duct system and duct system connections to plenums within 5 feet from the new work shall meet the sealing requirements of this code and be verified by a visual inspection by the state licensed conditioned air contractor or by a DET Verifier.

(Effective January 1, 2019)

*Add a new Section R403.3.6 ‘Joints, seams and Connections’ to read as follows:

R403.3.6 Joints, seams and Connections. All longitudinal and transverse joints, seams and connections in metallic and nonmetallic ducts shall be constructed as specified in *SMACNA HVAC Duct Construction Standards- Metal and Flexible* and *NAIMA Fibrous Glass Duct Construction Standards*. All joints, longitudinal and transverse seams, and connections in ductwork shall be securely fastened and sealed with welds, gaskets, mastics (adhesives), mastic-plus-embedded-fabric systems or tapes. Without exception all closure systems shall have mastic applied that is at least 0.08 inches (2 mm) thick.

Closure systems used to seal flexible air ducts and flexible air connections shall comply with UL 181B and shall be marked “181B-FX” for pressure-sensitive tape or “181B-M” for mastic. Duct connections to flanges of air distribution systems equipment shall be sealed and mechanically fastened. Mechanical fasteners for use with flexible non-metallic air ducts shall comply with UL 181B and shall be marked 181B-C. Crimp joints for round metallic ducts shall have a contact lap of not less than 1 inch (25.4 mm) and shall be mechanically fastened by means of not less than three sheet-metal screws or rivets equally spaced around the joint.

Closure systems used to seal metal ductwork shall be installed in accordance with manufacturer’s instructions. Round metallic ducts shall be mechanically fastened by means of at least three sheet metal screws or rivets spaced equally around the joint. Unlisted duct tape shall not be permitted as a sealant on any duct.

Exceptions:

1. Spray polyurethane foam shall be permitted to be applied without additional joint seals.
2. Where a duct connection is made that is partially inaccessible, three screws or rivets shall be equally spaced on the exposed portion of the joint so as to prevent a hinge effect.
3. Continuously welded and locking-type longitudinal joints and seams in ducts operating at static pressure less than 2 inches (51 mm) of water column (500 Pa) pressure classification shall not require additional closure systems.

(Effective January 1, 2019)

*Revise Section R403.5.4 ‘Drain water heat recovery units’ to read as follows:

R403.5.4 Drain water heat recovery units. Drain water heat recovery units shall comply with CSA B55.2 or IAPMO PS 92. Vertical drain water heat recovery units shall be tested in accordance with CSA B55.1 and have a minimum effectiveness of 42 percent when tested in accordance with CSA B55.1. Sloped drain water heat recovery units shall be tested in accordance with IAPMO IGC 346 and have a minimum rated effectiveness of 42 percent when tested in accordance with IAPMO IGC 346 at the minimum slope specified in the Georgia plumbing code. Potable water-side pressure loss of vertical drain water heat recovery units shall be less than 3 psi (20.7 kPa) for individual units connected to one or two showers. Potable water-side pressure loss of vertical drain water heat recovery units shall be less than 2 psi (13.8 kPa) for individual units connected to three or more showers. Potable water-side pressure loss of sloped drain water heat recovery units shall be less than 4 psi (20.7 kPa).

(Effective January 1, 2019)

*Revise Section R403.6 ‘Mechanical Ventilation’ to read as follows:

R403.6 Mechanical ventilation (Mandatory). Where required, the building shall be provided with ventilation that meets the requirements of the *International Residential Code* or *International Mechanical Code*, as applicable, or with ASHRAE 62.2-2016, *Ventilation and Acceptable Indoor Air Quality in Low-Rise Residential Buildings* (in entirety) or with other approved means of ventilation. Outdoor air intakes and exhausts shall have automatic or gravity dampers that close when the ventilation system is not operating.

(Remainder of section left unchanged)

(Effective January 1, 2019)

*Revise Section R403.7 ‘Equipment sizing and efficiency rating (Mandatory)’ by adding the following sentence at the end:

R403.7 Equipment sizing and efficiency rating (Mandatory). (The beginning of the section left unchanged) For automatically modulating capacity heating and cooling equipment, the system shall be deemed to comply with appropriate portions of Manual S provided the lowest output capacity of the equipment is less than the peak design load as determined by Manual J. (Effective January 1, 2019)

*Add new Section R403.13 ‘Power attic ventilators’ to read as follows:

R403.13 Electric powered attic ventilators. In new construction, electric powered attic ventilators shall not be connected to the Service supply premise wiring system. Solar photovoltaic (PV) powered attic ventilators shall be permitted. (Effective January 1, 2019)

**SECTION R406
ENERGY RATING INDEX
COMPLIANCE ALTERNATIVE**

*Revise Section R406.3 ‘Energy Rating Index’ to read as follows:

R406.3 Energy Rating Index. The Energy Rating Index (ERI) shall be determined in accordance with ANSI/RESNET/ICC 301 except for buildings constructed in accordance with the International Residential Code, where the ERI reference design ventilation rate shall be in accordance with the following:

$$\text{Ventilation rate} = (0.01 \times \text{total square foot area of house}) + (7.5 (N_{br} + 1))$$

Equation 4-1 where,

Ventilation rate is defined in units of cubic feet per
minute N_{br} = Number of bedrooms

The ERI shall consider all energy used in the *residential building* including *on-site renewable energy*. Energy used to recharge or refuel a vehicle for on-road (and off-site) transportation purposes shall not be included in the ERI *reference design* or the *rated design*. (Effective January 1, 2019)

*Delete Section R406.3.1 ‘ERI reference design’ without substitution. (Effective January 1, 2019)

*Revise Table R406.4 ‘MAXIMUM ENERGY RATING INDEX’ to read as follows:

**TABLE R406.4
MAXIMUM ENERGY RATING INDEX**

CLIMATE ZONE	ENERGY RATING INDEX
2	57
3	57
4	62

(Effective January 1, 2019)

*Revise Section R406.6.1 ‘Compliance software tools’ to read as follows:

R406.6.1 Compliance software tools. The ERI shall be determined using Approved Software Rating Tools in accordance with ANSI/RESNET/ICC 301.
(Effective January 1, 2019)

*Delete Section R406.7 ‘Calculation software tools’ without substitution.
(Effective January 1, 2019)

*Delete Section R406.7.1 ‘Minimum capabilities’ without substitution.
(Effective January 1, 2019)

*Revise and rename Section R406.7.2 ‘Specific approval’ to read as follows:
(Effective January 1, 2019)

R406.6.4 Specific approval. Performance analysis tools meeting the applicable sections of Section R406 shall be *approved*. Documentation demonstrating the approval of performance analysis tools in accordance with Section R406.6.1 shall be provided to *WKH FRGH RIILFLDO* The *code official* shall approve tools for a specified application or limited scope.
(Effective January 1, 2019)

*Revise and rename Section R406.7.3 ‘Input values’ to read as follows:

R406.6.5 Input values. Where calculations require input values not specified by Sections R402, R403, R404 and R405, those input values shall be taken from ANSI/RESNET/ICC 301.
(Effective January 1, 2019)

**CHAPTER 5 [RE]
EXISTING BUILDINGS**

**SECTION R502
ADDITIONS**

*Revise Section R502.1.1.2 'Heating and cooling systems' to delete the exception and substitute to read as follows:

R502.1.1.2 Heating and cooling systems. New heating, cooling and duct systems that are part of the addition shall comply with Sections R403.1, R403.2, R403.3, R403.5 and R403.6.

Exception: Duct tightness testing is not required for existing duct systems unless more than 50% of the existing duct system is modified.

(Effective January 1, 2019)

**SECTION R503
ALTERATIONS**

*Revise Section R503.1.2 'Heating and cooling systems' to read as follows:

R503.1.2 Heating and cooling systems. New heating, cooling and duct systems that are part of the alteration shall comply with Sections R403.1, R403.2, R403.3 and R403.6.

Exception: Duct tightness testing is not required for existing duct systems unless more than 50% of the existing duct system is modified.

(Effective January 1, 2019)

**CHAPTER 6 [RE]
REFERENCED STANDARDS**

*Revise Chapter 6 ‘Referenced Standards’ to add the following new Standards to read as follows:

UL		
	UL LLC 333 Pfingsten Road Northbrook, IL 60062-2096	
<u>Standard reference number</u>	<u>Title</u>	<u>Referenced in code section number</u>
181 - 2013	Factory-made Air Ducts and Air Connectors—with Revisions through May 2003	R403.3.6
181A - 2013	Closure Systems for Use with Rigid Air Ducts and Air Connectors—with Revisions through December 1998	R403.3.6
181B - 2013	Closure Systems for Use with Flexible Air Ducts and Air Connectors—with Revisions through August 2003	R403.3.6
ASHRAE		
	American Society of Heating, Refrigerating and Air-Conditioning Engineers, Inc. 1791 Tullie Circle, NE Atlanta, GA 30329-2305	
<u>Standard reference number</u>	<u>Title</u>	<u>Referenced in code section number</u>
ASHRAE 62.2 – 2016	Ventilation and Acceptable Indoor Air Quality in Low- Rise Residential Buildings	R403.6
ANSI/RESNE T/ICC 301		
	Residential Energy Services Network, Inc. P.O. Box 4561. Oceanside, CA 92052-4561 International Code Council, 500 New Jersey Avenue, NW, 6th Floor. Washington, D.C. 20001	
<u>Standard reference number</u>	<u>Title</u>	<u>Referenced in code section number</u>
ANSI/RESNET/ICC 301-2014	Standard for the Calculation and Labeling of the Energy Performance of Low-Rise Residential Buildings using an Energy Rating Index	R406
IAPMO PS 92		
	IAPMO 4755 E. Philadelphia St. Ontario, CA 91761 – USA	
<u>Standard reference number</u>	<u>Title</u>	<u>Referenced in code section number</u>
IAPMO PS 92-2013	Heat Exchangers and Indirect Water Heaters	R403.5.4
IAPMO IGC 346	Test Method for Measuring the Performance of Drain Water Heat Recovery Units	R403.5.4

(Standards not listed to remain unchanged)

APPENDICES

Throughout these appendices there is information that may be helpful in meeting and understanding the *Georgia State Minimum Standard Energy Code*. In cases of conflict, refer to the *2015 International Energy Conservation Code* for clarification.

APPENDIX RA

*Delete APPENDIX RA ‘RECOMMENDED PROCEDURE FOR WORST-CASE TESTING OF ATMOSPHERIC VENTING SYSTEMS UNDER R402.4 OR R405 CONDITIONS ≤ 5 ACH50’, entirely and substitute with new APPENDIX RA ‘AIR SEALING KEY POINTS’.
(Effective January 1, 2019)

APPENDIX RC

*Add new APPENDIX RC ‘THIRD PARTY VERIFICATION’.
(Effective January 1, 2019)

APPENDIX RD

*Add new APPENDIX RD ‘MANDATORY COMPLIANCE CERTIFICATE’.
(Effective January 1, 2019)

The above referenced form, Mandatory Compliance Certificate is available to download for free from DCA’s webpage located at: <https://dca.ga.gov/node/3522/documents/2090>

End of Supplements and Amendments.

Appendix RA

Air Sealing and Insulation Key Points

Air Barrier and Insulation Installation Component Guide

	COMPONENT	AIR BARRIER CRITERIA	INSULATION INSTALLATION CRITERIA
1	General requirements	A continuous air barrier shall be installed in the building envelope. The exterior thermal envelope contains a continuous air barrier. Breaks or joints in the air barrier shall be sealed.	Air-permeable insulation shall not be used as a sealing material.
2	Ceiling/attic	The air barrier in any dropped ceiling/soffit shall be aligned with the insulation and any gaps in the air barrier shall be sealed. Access openings, drop down stairs or knee wall doors to unconditioned attic spaces shall be sealed.	The insulation in any dropped ceiling/soffit shall be aligned with the air barrier.
3	Walls	The junction of the foundation and sill plate shall be sealed. The junction of the top plate and the top of exterior walls shall be sealed. Knee walls shall be sealed.	Cavities within corners and headers of frame walls shall be insulated by completely filling the cavity with a material having a thermal resistance of R-3 per inch minimum. Exterior thermal envelope insulation for framed walls shall be installed in substantial contact and continuous alignment with the air barrier.
4	Windows, skylights and doors	The space between window/door jambs and framing, and skylights and framing shall be sealed.	
5	Rim joists	Rim joists shall include the air barrier.	Rim joists shall be insulated.
6	Floors (including above garage and cantilevered floors)	The air barrier shall be installed at any exposed edge of insulation.	Floor framing cavity insulation shall be installed to maintain permanent contact with the underside of subfloor decking, or floor framing cavity insulation shall be permitted to be in contact with the top side of sheathing, or continuous insulation installed on the underside of floor framing and extends from the bottom to the top of all perimeter floor framing members.
7	Crawl space walls	Exposed earth in unvented crawl spaces shall be covered with a Class I vapor retarder with overlapping joints taped.	Where provided instead of floor insulation (unvented crawl spaces), insulation shall be permanently attached to the crawlspace walls.
8	Shafts, penetrations	Duct shafts, utility penetrations, and flue shafts opening to exterior or unconditioned space shall be sealed.	Capped chases shall be insulated to surrounding ceiling R-values (maintain clearance from combustion flues).
9	Narrow cavities		Batts in narrow cavities shall be cut to fit, or narrow cavities shall be filled by insulation that on installation readily conforms to the available cavity space.
10	Garage separation	Air sealing shall be provided between the garage and conditioned spaces.	Band area shall be blocked, sealed and insulated.
11	Recessed lighting	Recessed light fixtures installed in the building thermal envelope shall be sealed to the drywall.	Recessed light fixtures installed in the building thermal envelope shall be air tight and IC rated.
12	Plumbing and wiring	Wiring and plumbing penetrations shall be sealed.	Batt insulation shall be cut neatly to fit around wiring and plumbing in exterior walls, or insulation that on installation readily conforms to available space shall extend behind piping and wiring.
13	Shower/tub on exterior wall	The air barrier installed at exterior walls adjacent to showers and tubs shall separate them from the showers and tubs.	Exterior walls adjacent to showers and tubs shall be insulated.
14	Electrical/phone box on exterior walls	The air barrier shall be installed behind electrical or communication boxes or air-sealed boxes shall be installed.	
15	HVAC register boots	HVAC register boots shall be sealed to the subfloor or drywall.	Boots in unconditioned spaces shall be insulated. Recommend insulating boots in conditioned spaces for condensation control.
16	Concealed sprinklers	When required to be sealed, concealed fire sprinklers shall only be sealed in a manner that is recommended by the manufacturer. Caulking or other adhesive sealants shall not be used to fill voids between fire sprinkler cover plates and walls or ceilings.	
17	Blocking between framing (e.g. beneath knee walls, cantilevered floors, garage separation walls)	Blocking shall be sealed to framing.	Insulation shall be in contact with blocking.
18	Common walls	Air barrier is installed in common wall between dwelling units.	
19	Fireplaces	New wood-burning fireplaces shall have tight-fitting flue dampers or doors, and outdoor combustion air.	Fireplace chase insulation shall be restrained to stay in place.

Disclaimer: This document was created by Southface and is intended solely to help graphically demonstrate the air leakage and insulation provisions of the 2015 IECC (2019 Georgia Energy Code). It does not cover all air sealing locations, materials or techniques. Other code provisions may be applicable as well.

Air sealing key points *continued*

Chases and common by-passes

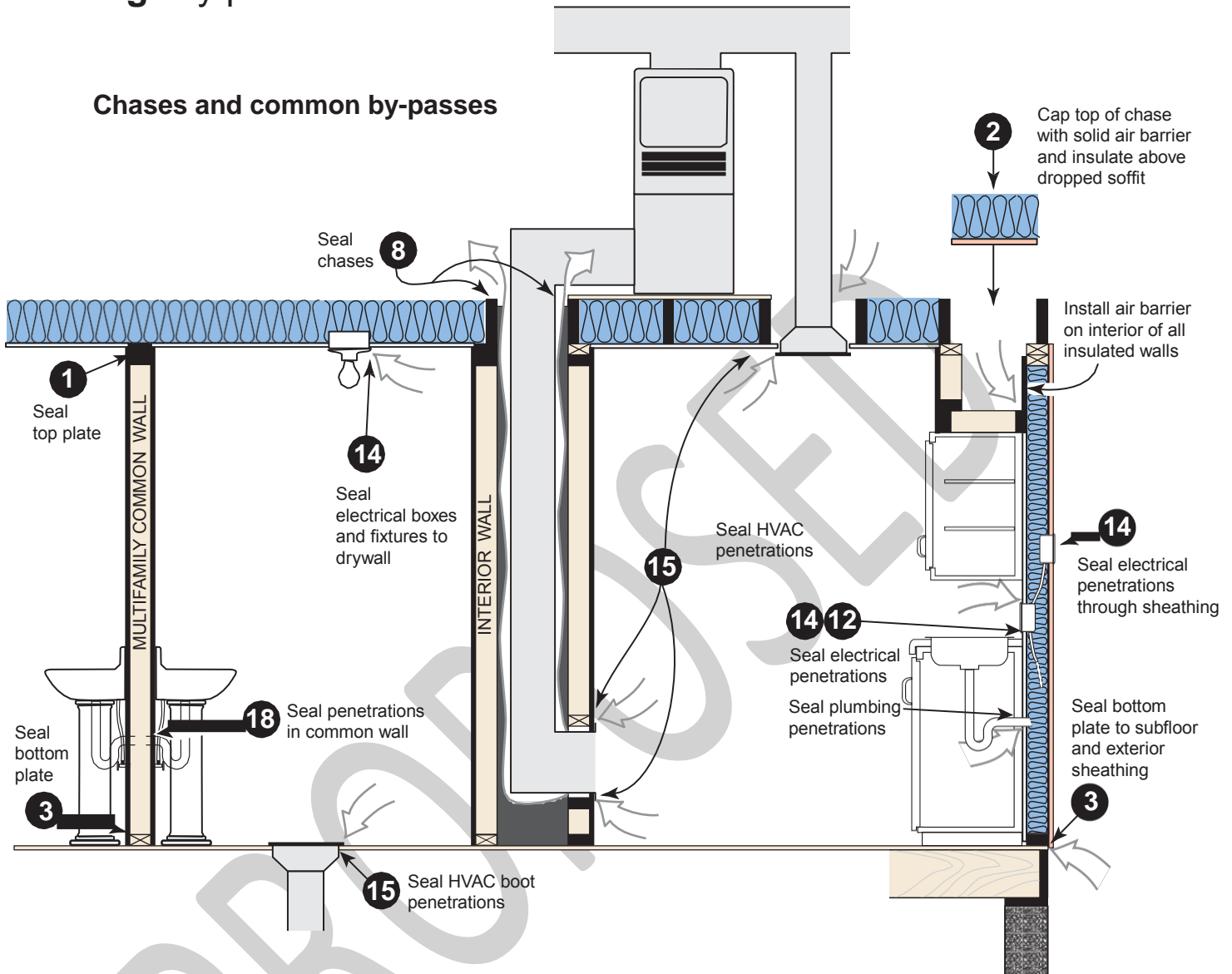

Shower/tub drain rough opening

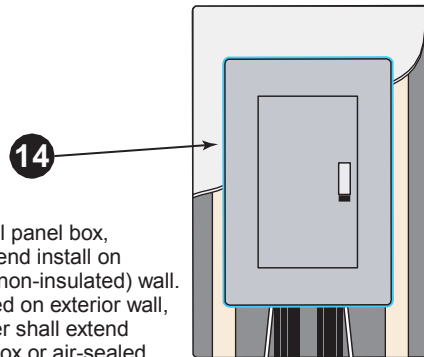
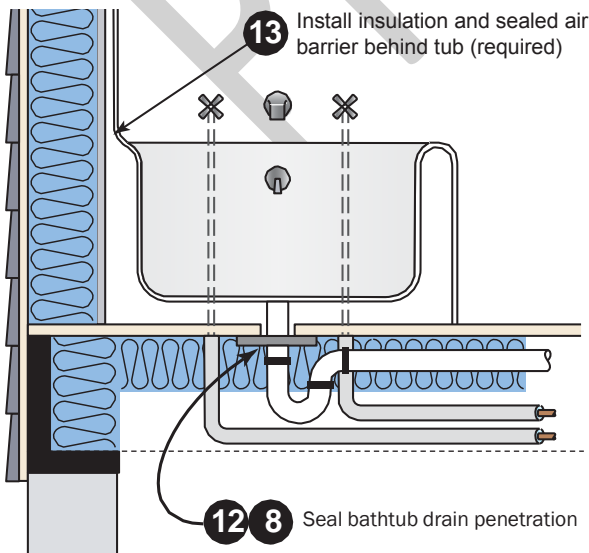

Electrical panel box, recommend install on interior (non-insulated) wall. If installed on exterior wall, air barrier shall extend behind box or air-sealed box shall be installed.

Disclaimer:
This document was created by Southface and is intended solely to help graphically demonstrate the air leakage and insulation provisions of the 2015 IECC (2019 Georgia Energy Code). It does not cover all air sealing locations, materials or techniques. Other code provisions may be applicable as well.

Air sealing key points *continued*

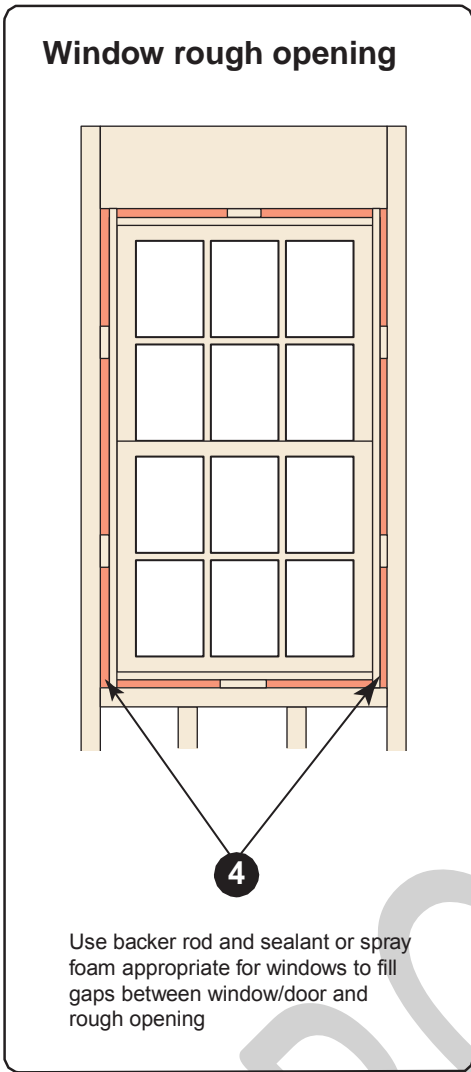

Wall cross-section

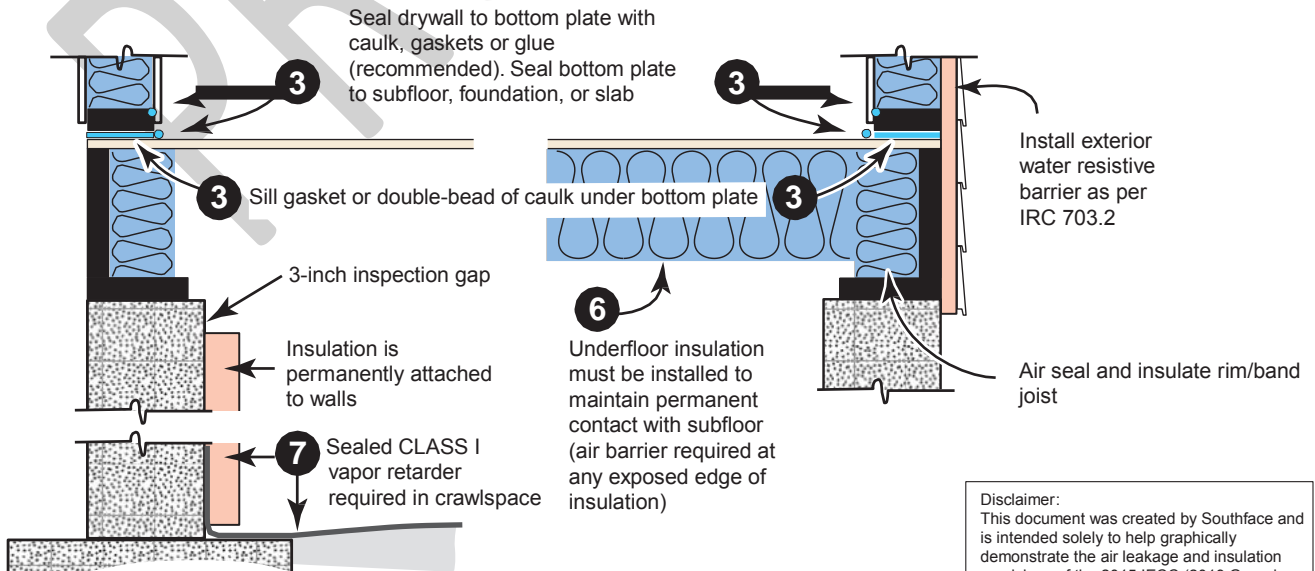
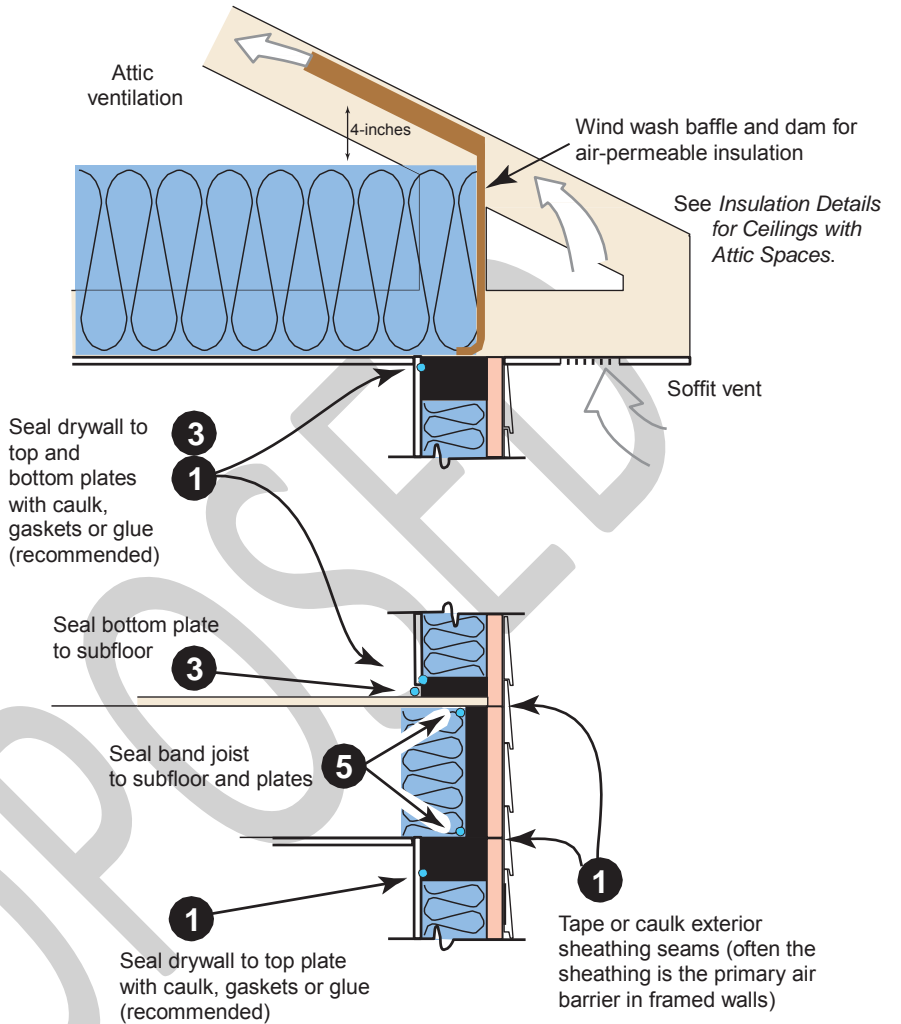

Disclaimer:
 This document was created by Southface and is intended solely to help graphically demonstrate the air leakage and insulation provisions of the 2015 IECC (2019 Georgia Energy Code). It does not cover all air sealing locations, materials or techniques. Other code provisions may be applicable as well.

Air sealing key points *continued*

Combustion chase penetrations

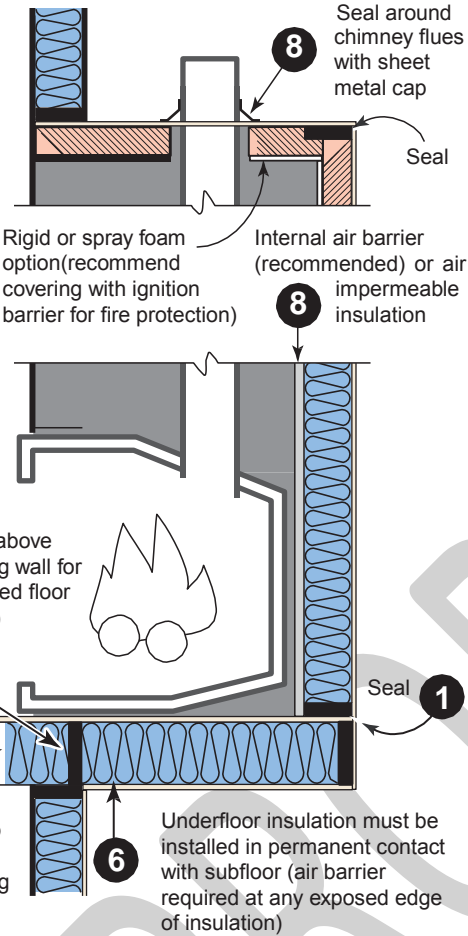

Exterior penetrations

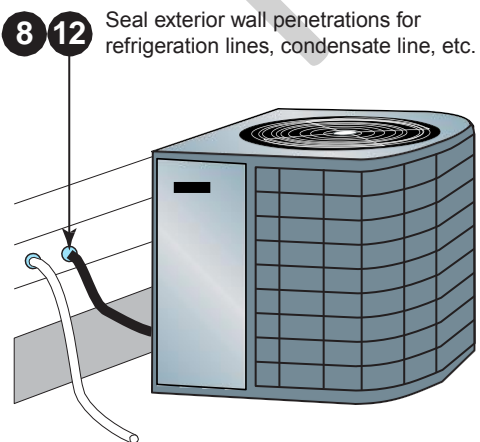

Combustion closet

Combustion air inlets
as per mechanical and/or fuel gas code

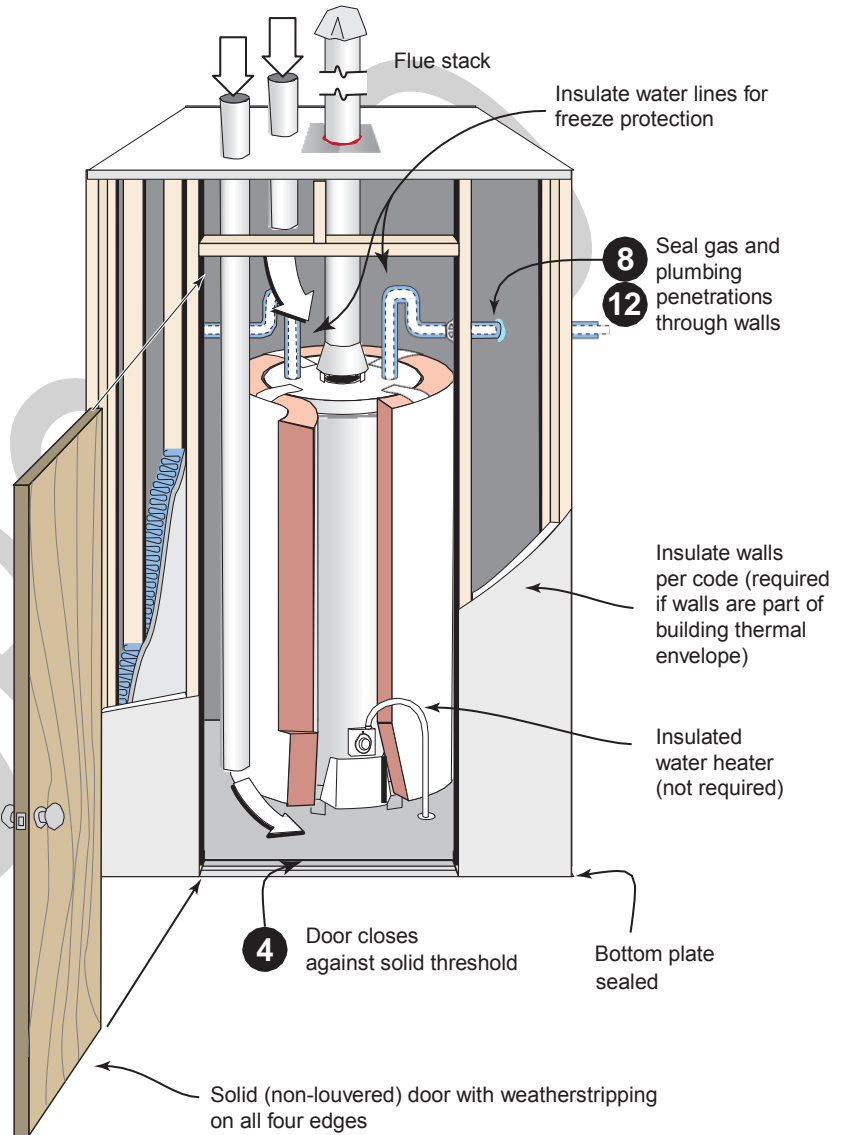

Disclaimer:
This document was created by Southface and is intended solely to help graphically demonstrate the air leakage and insulation provisions of the 2015 IECC (2019 Georgia Energy Code). It does not cover all air sealing locations, materials or techniques. Other code provisions may be applicable as well.

Air sealing key points *continued*

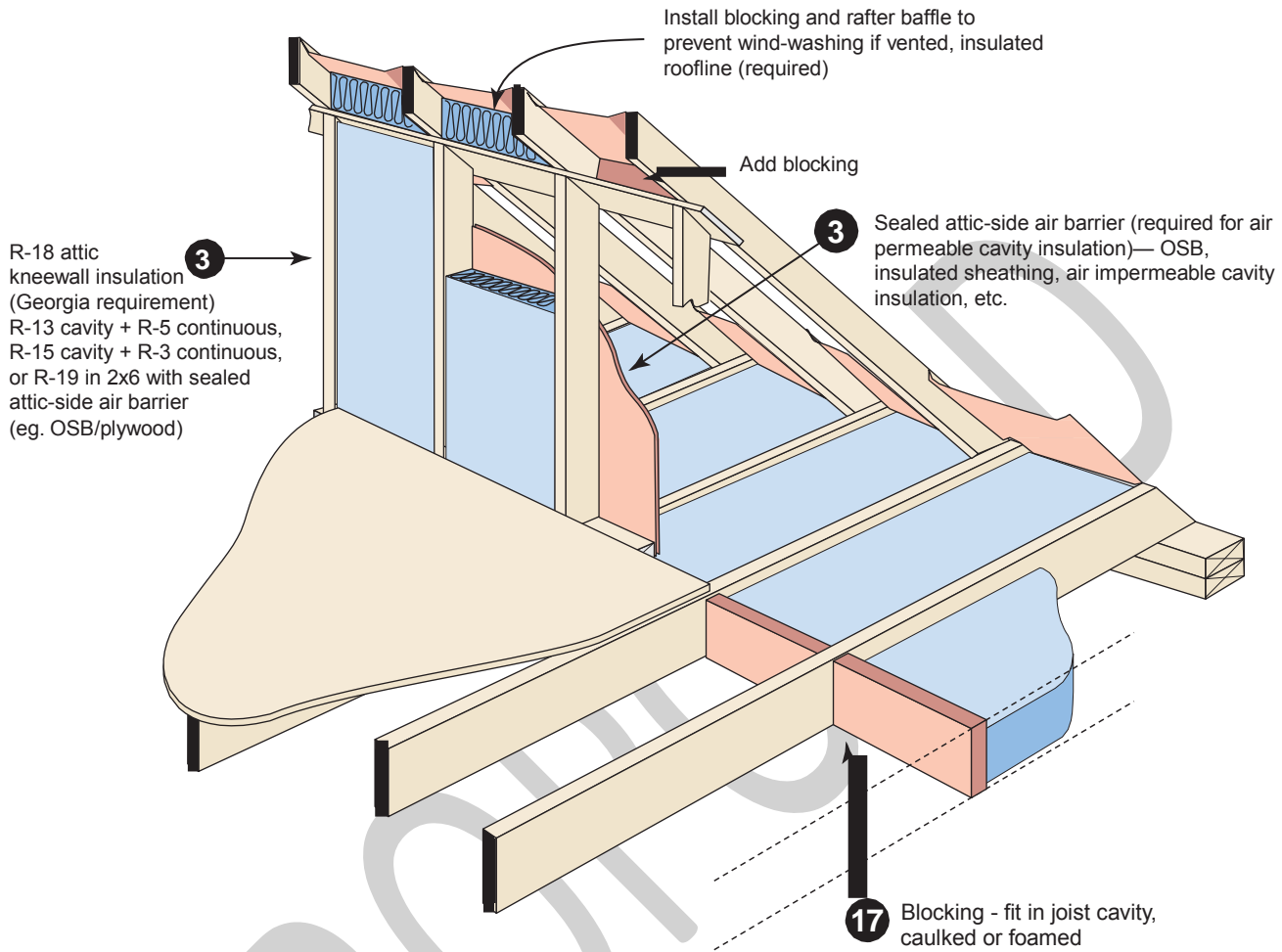

Attic knee-walls

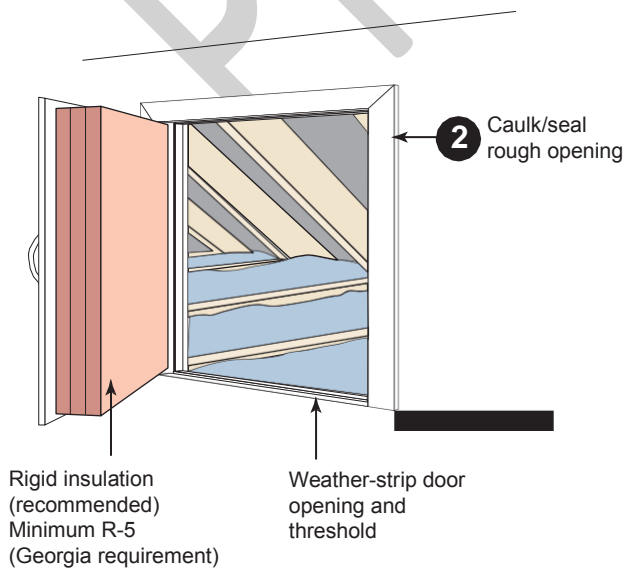

Two-level attic

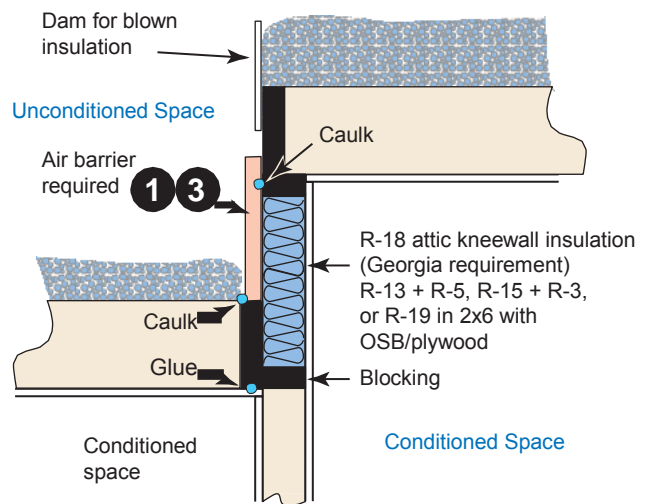

Disclaimer:
This document was created by Southface and is intended solely to help graphically demonstrate the air leakage and insulation provisions of the 2015 IECC (2019 Georgia Energy Code). It does not cover all air sealing locations, materials or techniques. Other code provisions may be applicable as well.

Air sealing key points *continued*

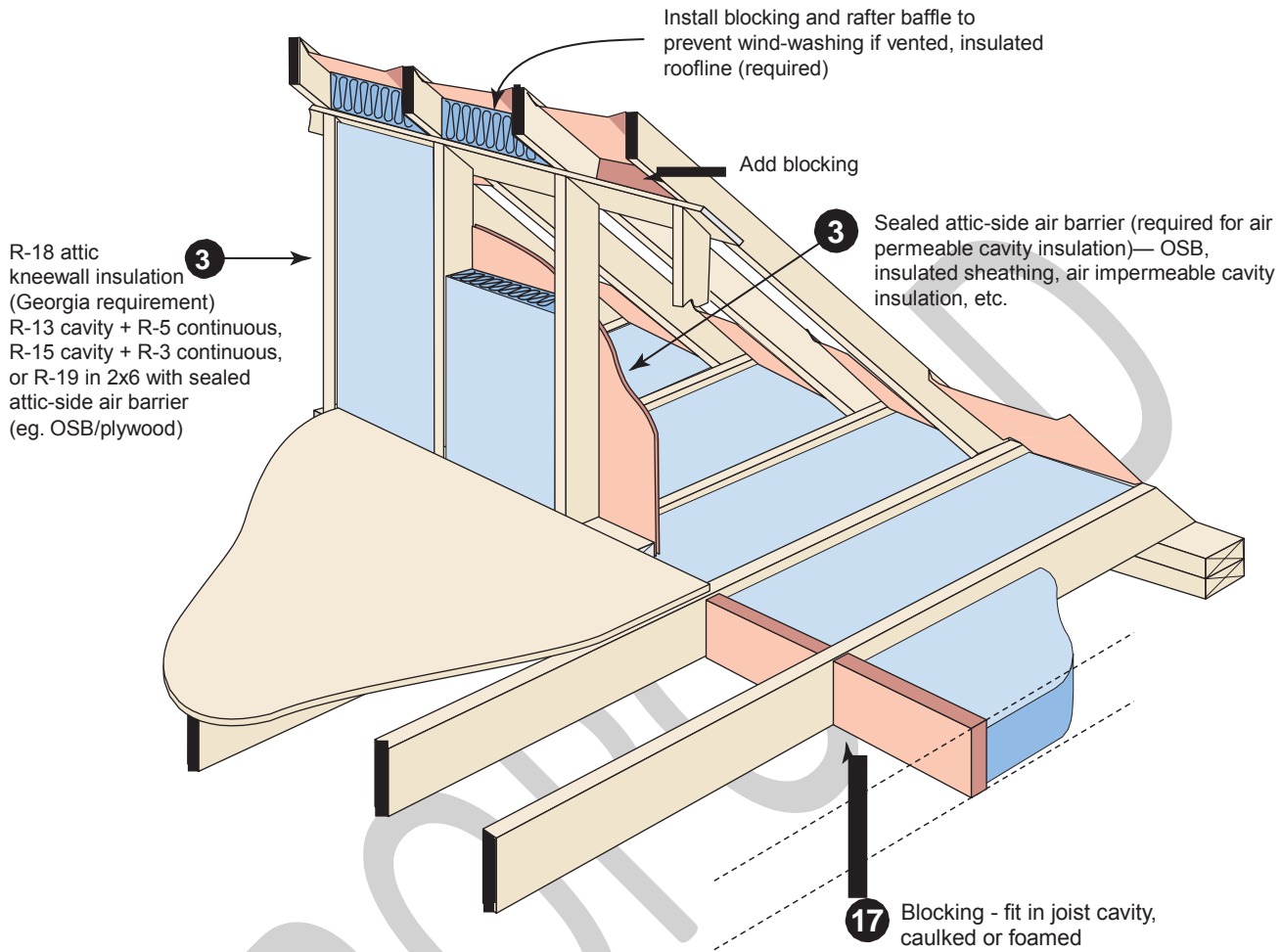

Attic knee-walls

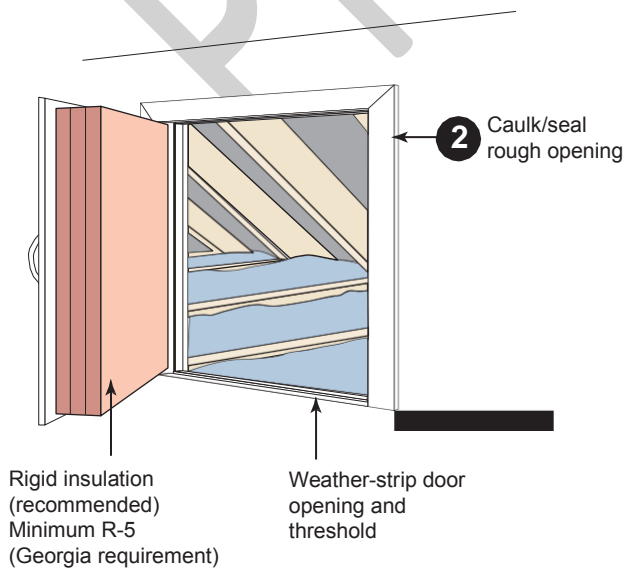

Two-level attic

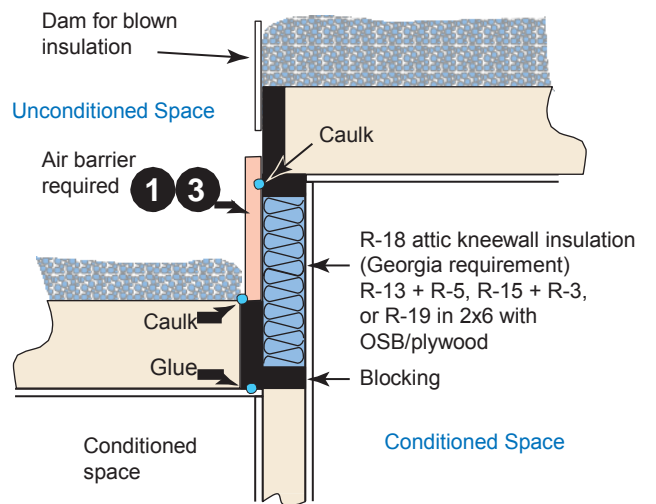

Disclaimer:
This document was created by Southface and is intended solely to help graphically demonstrate the air leakage and insulation provisions of the 2015 IECC (2019 Georgia Energy Code). It does not cover all air sealing locations, materials or techniques. Other code provisions may be applicable as well.

Air sealing key points *continued*

Attic scuttle

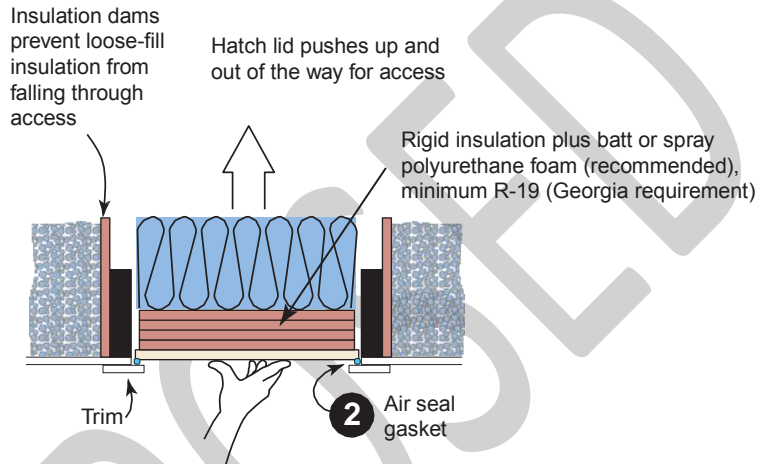

Attic pull-down stairs

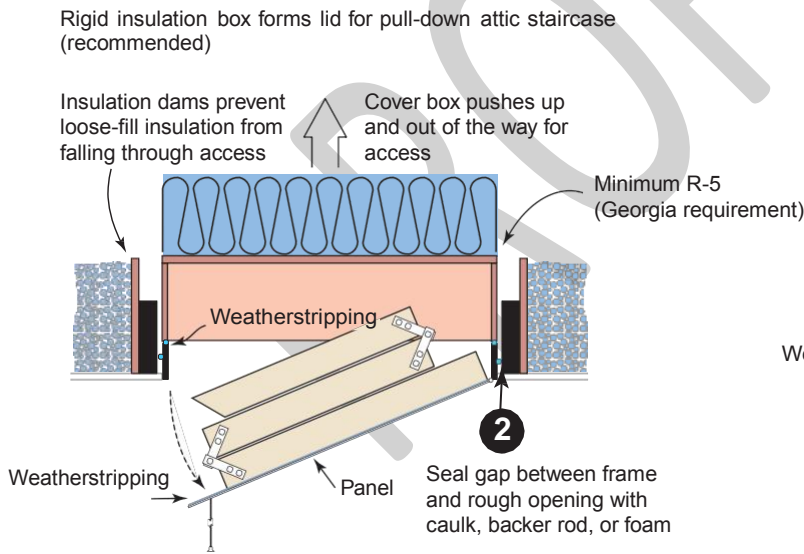

Boxed enclosure for staircase has rigid hinged lid with insulation on top

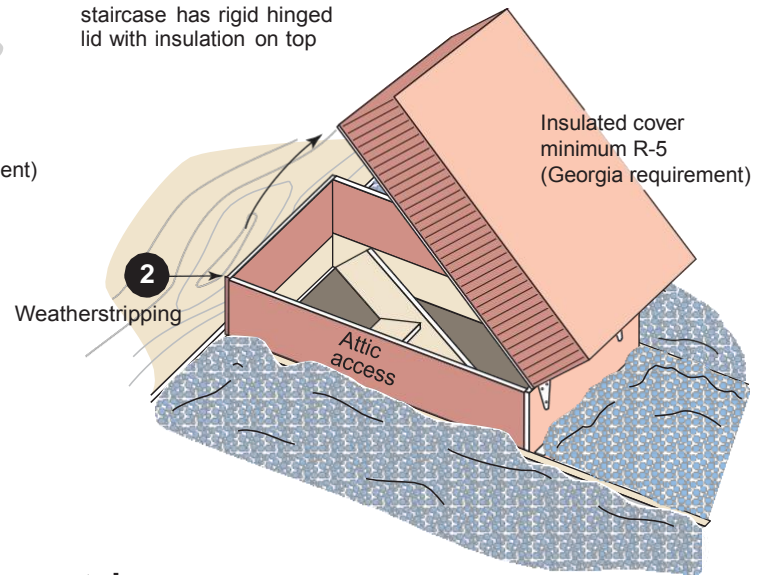

Attic pull-down stairs

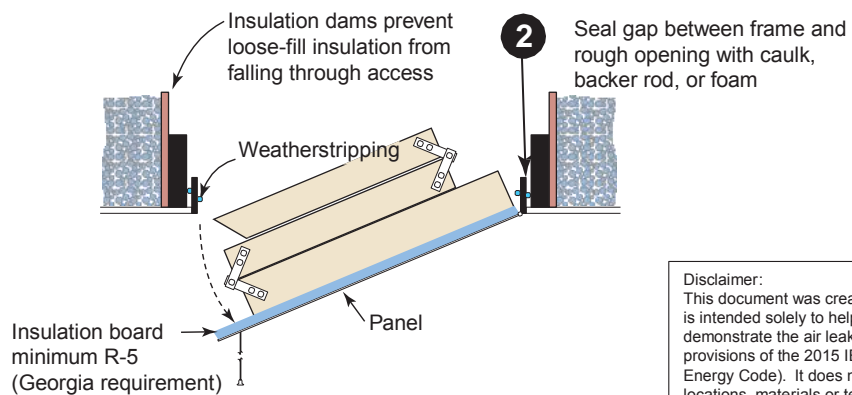

Disclaimer:
This document was created by Southface and is intended solely to help graphically demonstrate the air leakage and insulation provisions of the 2015 IECC (2019 Georgia Energy Code). It does not cover all air sealing locations, materials or techniques. Other code provisions may be applicable as well.

Air sealing key points *continued*

Attic scuttle

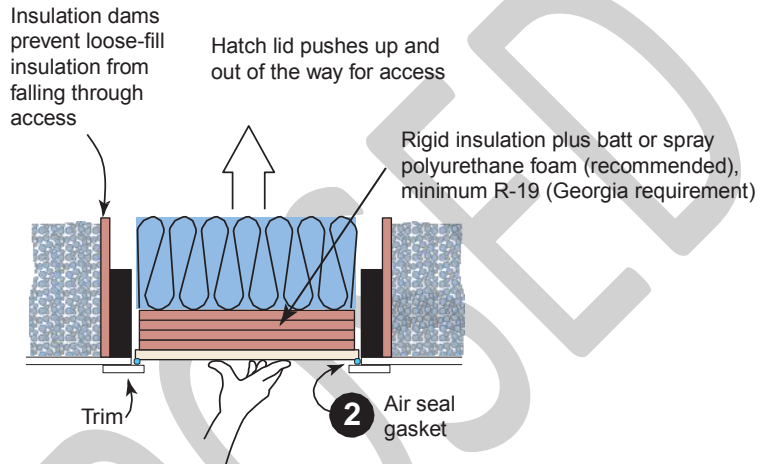

Attic pull-down stairs

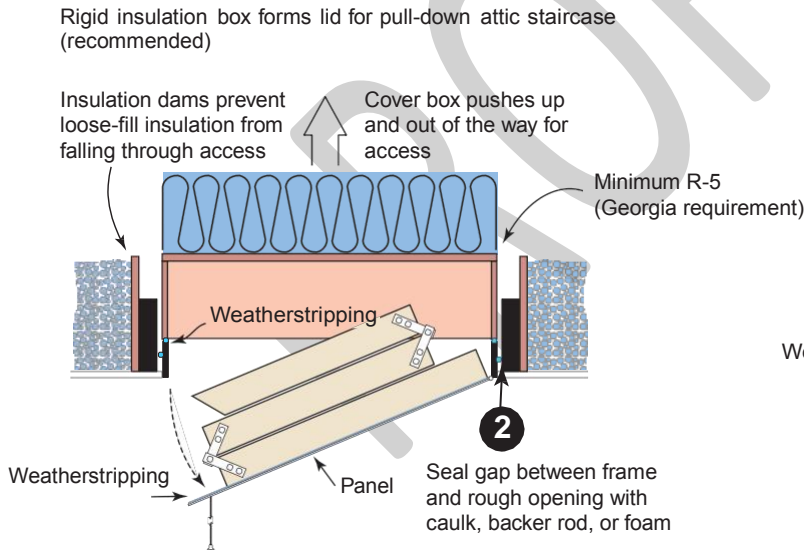

Boxed enclosure for staircase has rigid hinged lid with insulation on top

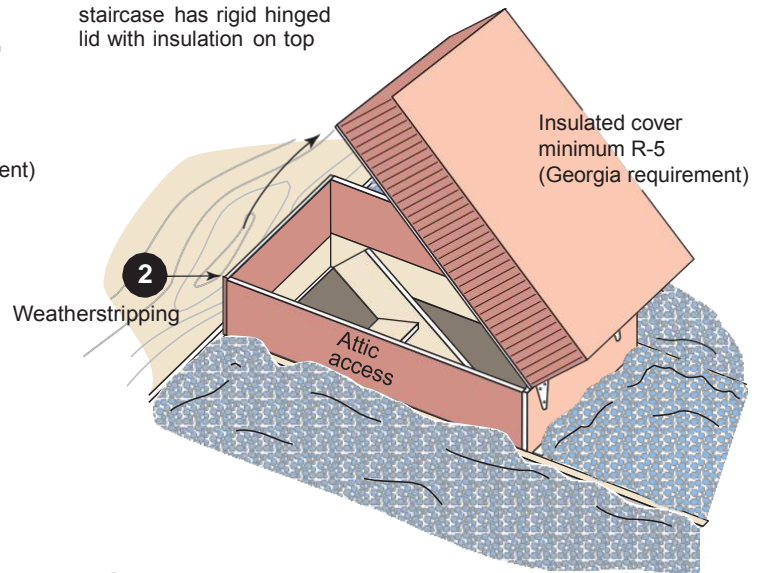

Attic pull-down stairs

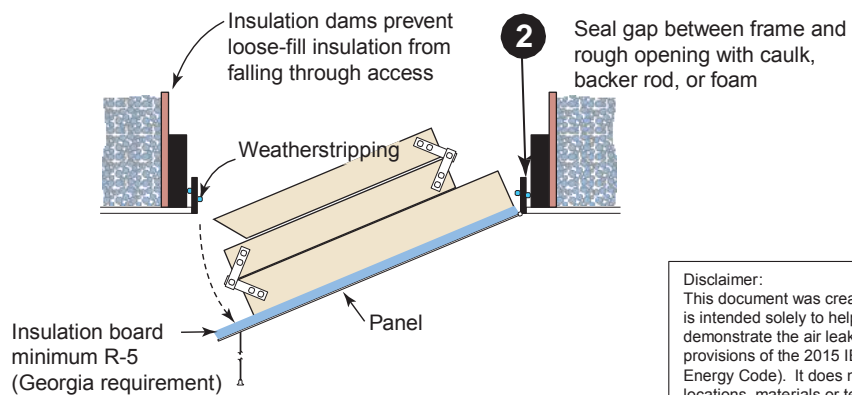

Disclaimer:
This document was created by Southface and is intended solely to help graphically demonstrate the air leakage and insulation provisions of the 2015 IECC (2019 Georgia Energy Code). It does not cover all air sealing locations, materials or techniques. Other code provisions may be applicable as well.

Garage blocking and sealing key points

Blocking, air sealing and insulation required above garage separation wall

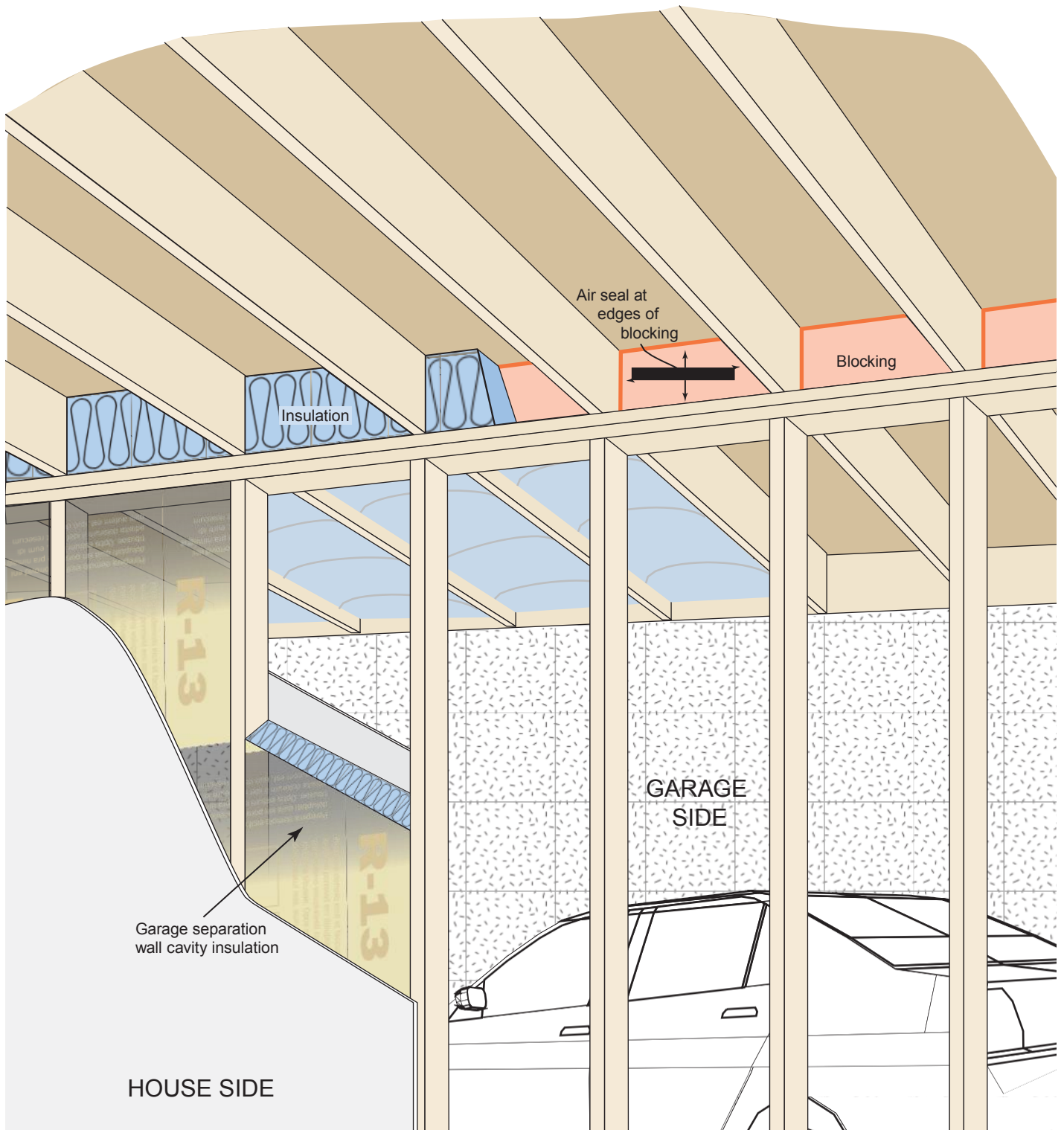

Disclaimer:
This document was created by Southface and is intended solely to help graphically demonstrate the air leakage and insulation provisions of the 2015 IECC (2019 Georgia Energy Code). It does not cover all air sealing locations, materials or techniques. Other code provisions may be applicable as well.

Air sealing key points *continued*

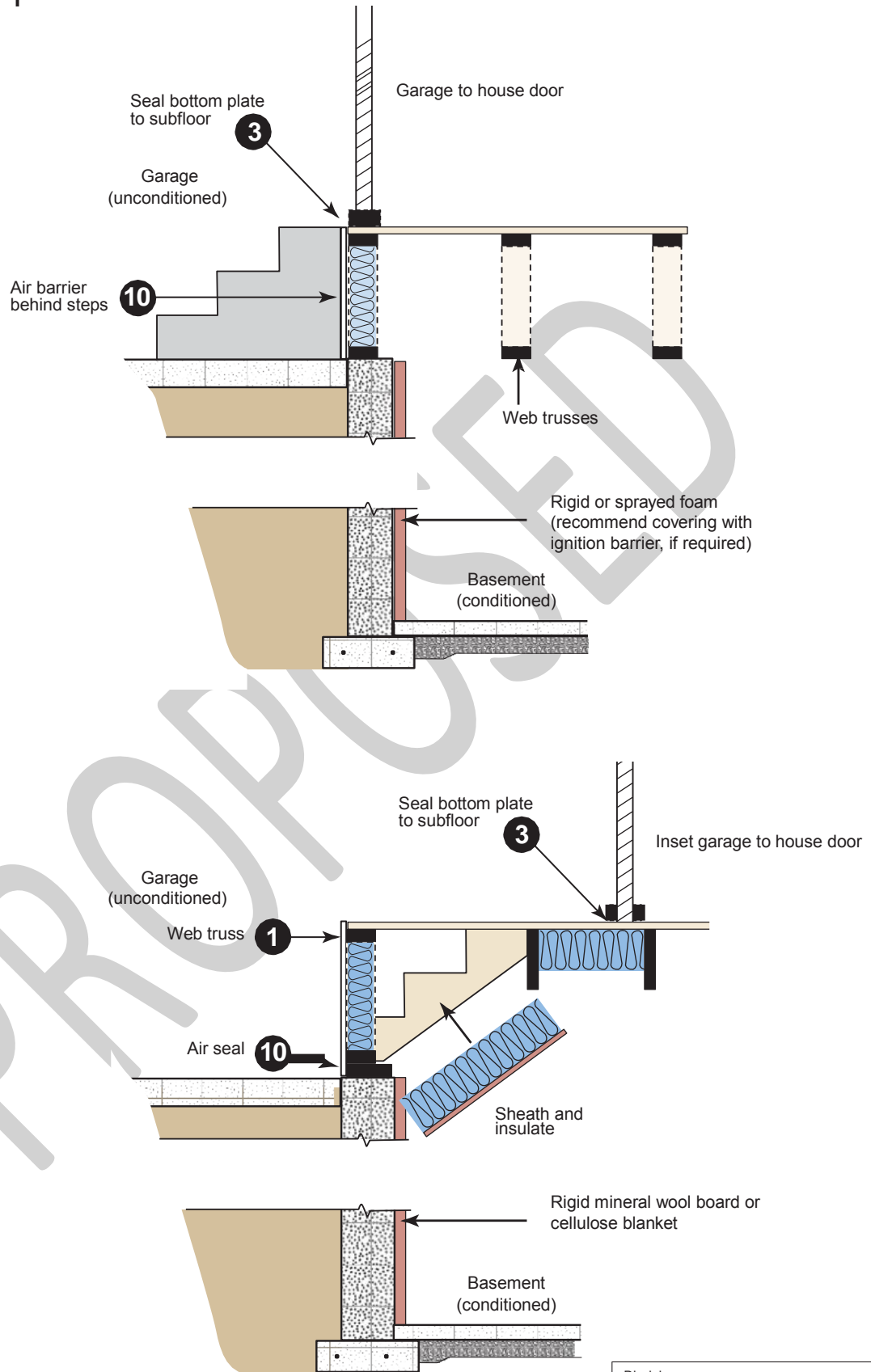

Disclaimer:
This document was created by Southface and is intended solely to help graphically demonstrate the air leakage and insulation provisions of the 2015 IECC (2019 Georgia Energy Code). It does not cover all air sealing locations, materials or techniques. Other code provisions may be applicable as well.

Duct Sealing key points

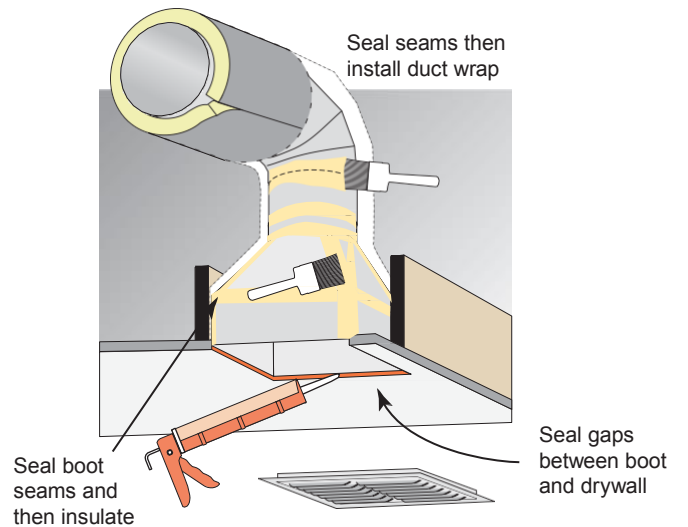
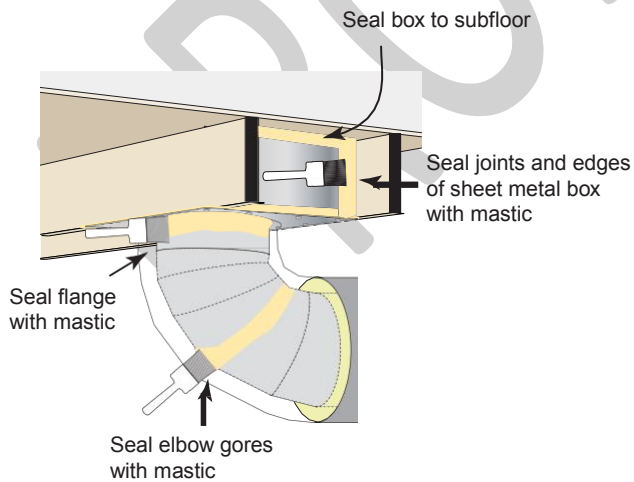
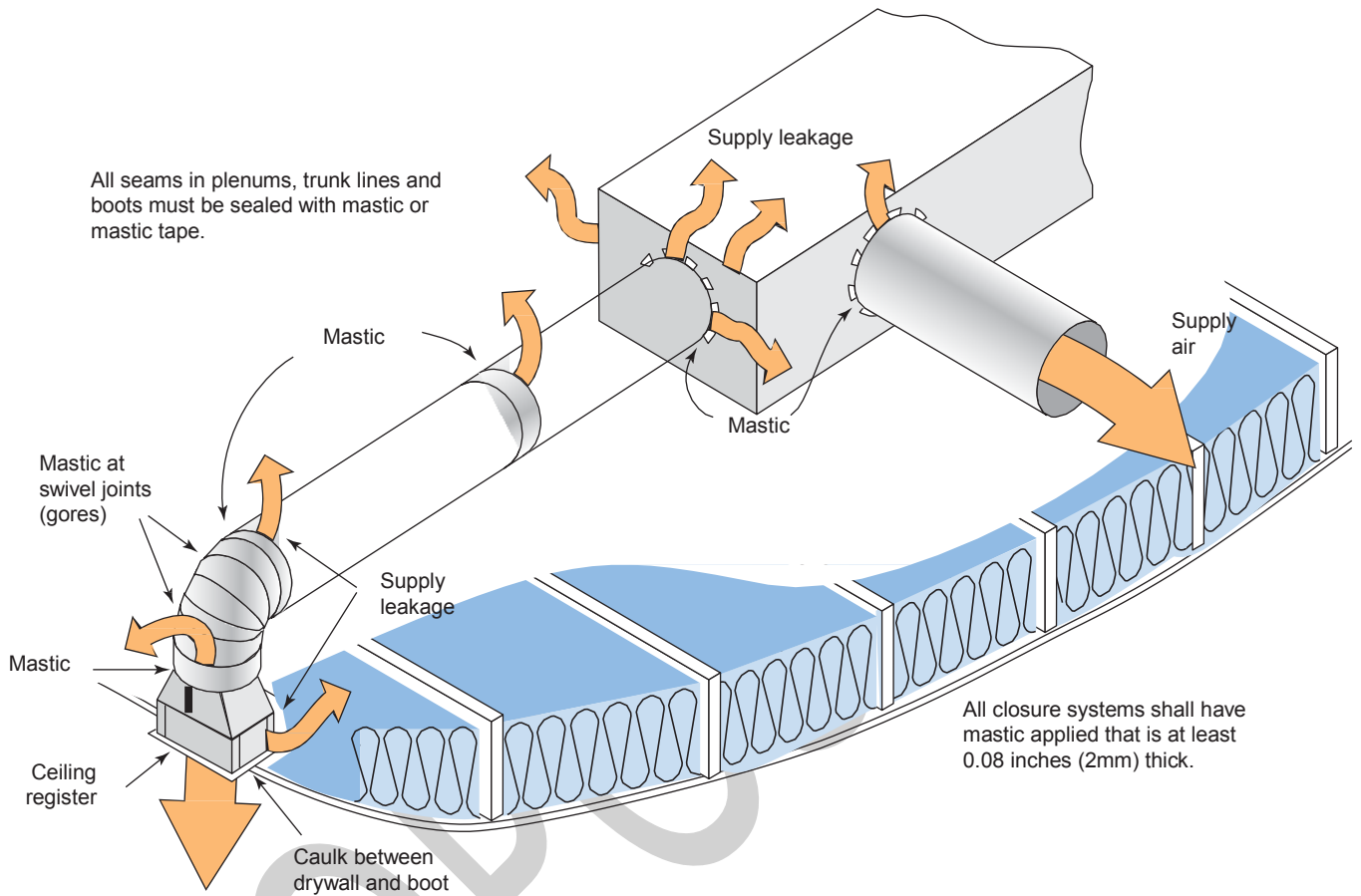

Disclaimer:
 This document was created by Southface and is intended solely to help graphically demonstrate the air leakage and insulation provisions of the 2015 IECC (2019 Georgia Energy Code). It does not cover all air sealing locations, materials or techniques. Other code provisions may be applicable as well.

Air Handler Sealing key points

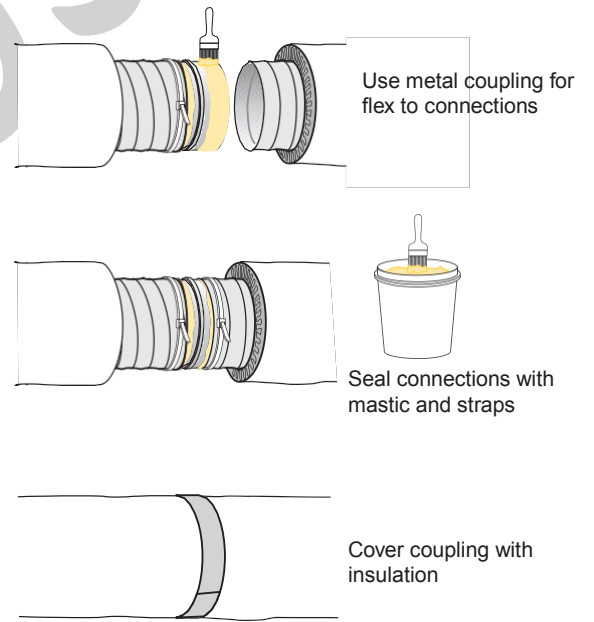
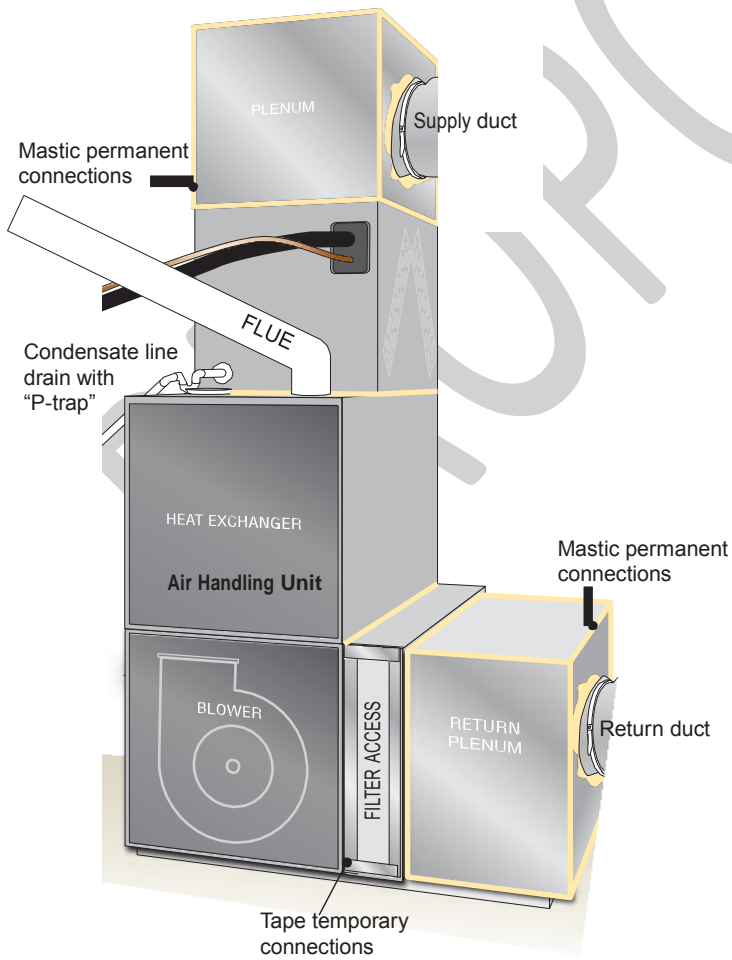
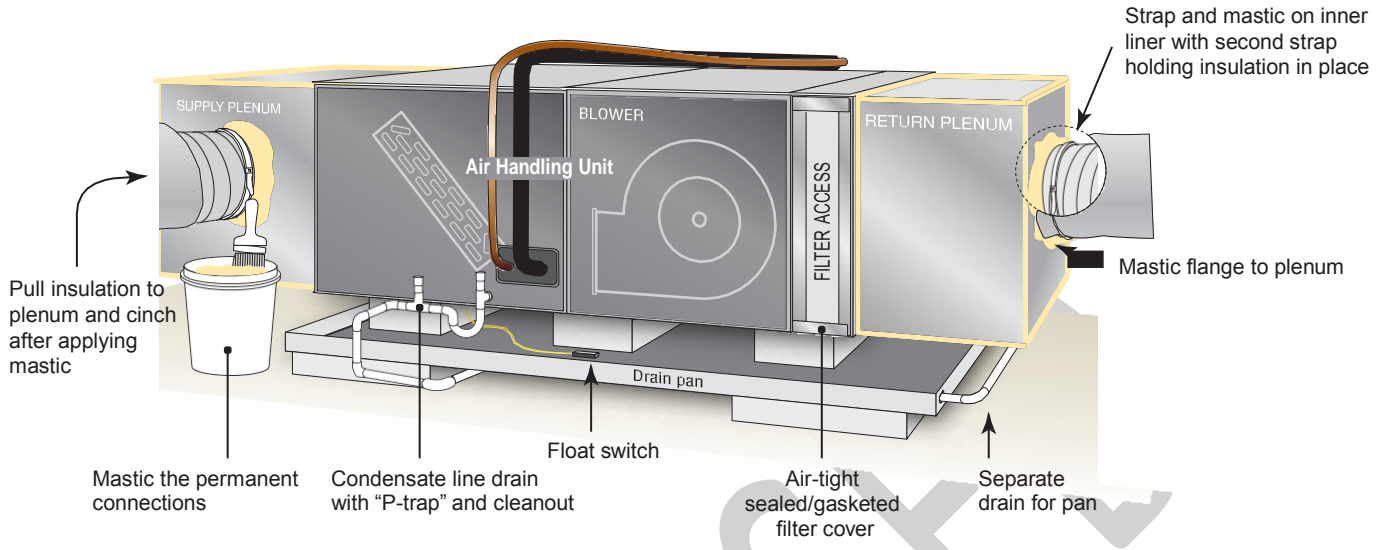

Disclaimer:
 This document was created by Southface and is intended solely to help graphically demonstrate the air leakage and insulation provisions of the 2015 IECC (2019 Georgia Energy Code). It does not cover all air sealing locations, materials or techniques. Other code provisions may be applicable as well.

Air sealing key points *continued*

Multifamily

Multifamily Air-sealing Details

- 8 Cap and seal all chases including chases for grouped utility lines and radon vents

Seal penetrations in mechanical closet including penetrations for the:

- 8 supply plenum
 - 8 outside air ventilation
 - 8 12 refrigerant line
 - 12 plumbing
 - 12 14 electrical
 - 12 gas fuel
- 5 Seal band area at exterior sheathing side and all penetrations through band
 - 1 3 UL-compliant air sealing at drywall finishing for any wall adjacent to stairwell or elevator. Air seal this gap at every change in floor level
 - 8 Seal miscellaneous clustered penetrations through building envelope (e.g. refrigerant lines)

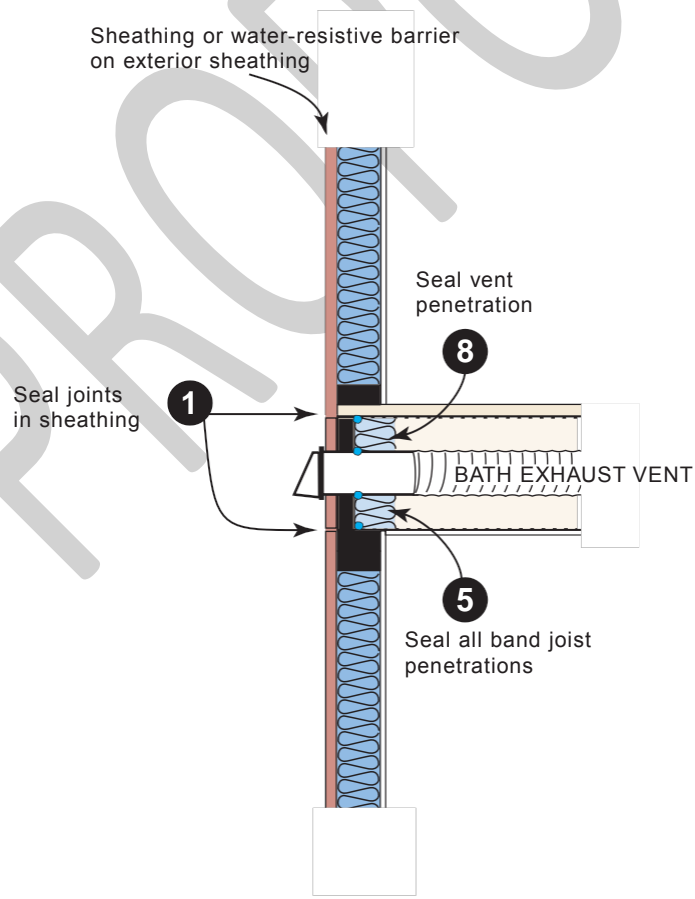

Disclaimer:
 This document was created by Southface and is intended solely to help graphically demonstrate the air leakage and insulation provisions of the 2015 IECC (2019 Georgia Energy Code). It does not cover all air sealing locations, materials or techniques. Other code provisions may be applicable as well.

Air sealing key points *continued*

Multifamily

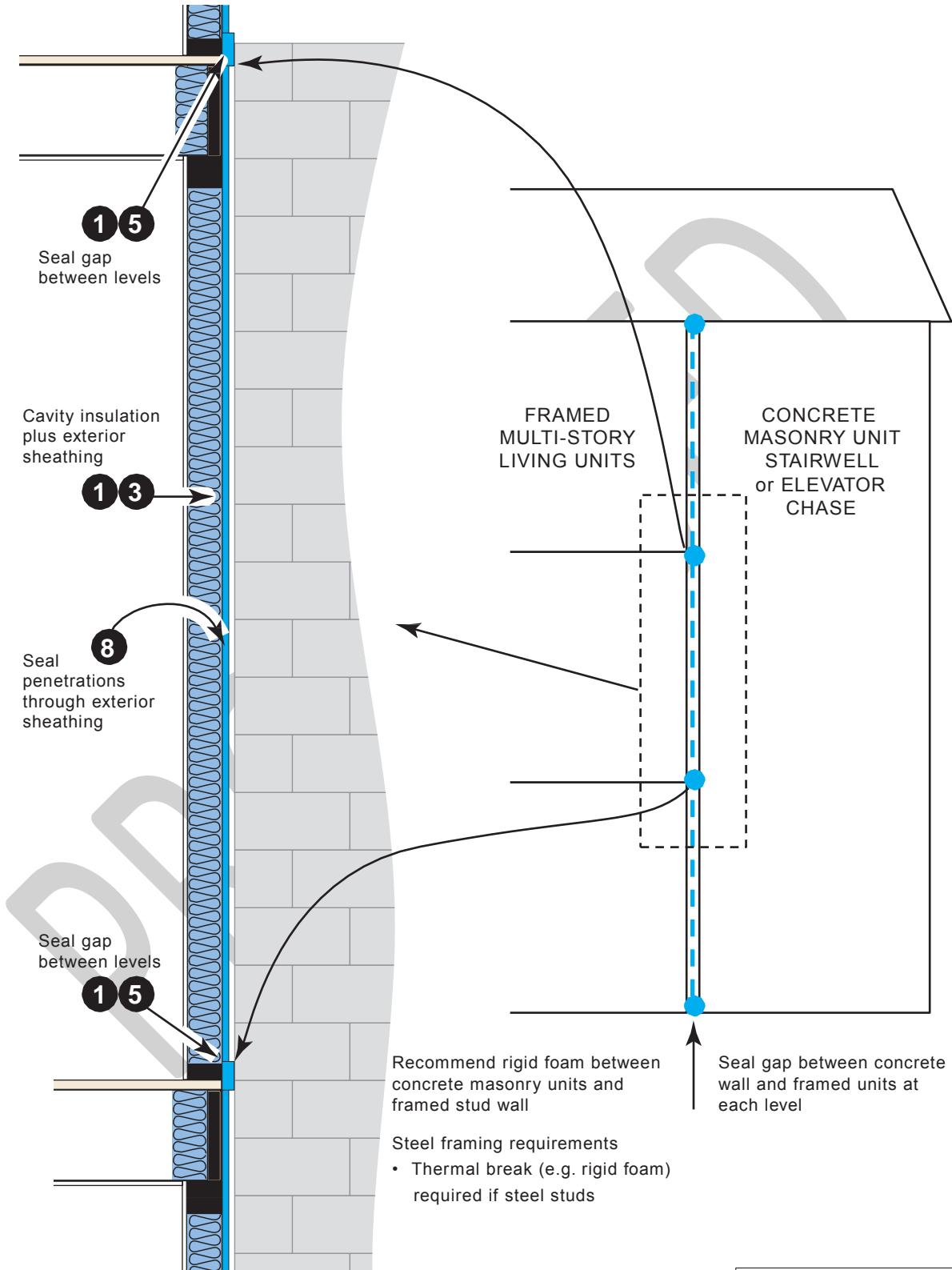

Disclaimer:
This document was created by Southface and is intended solely to help graphically demonstrate the air leakage and insulation provisions of the 2015 IECC (2019 Georgia Energy Code). It does not cover all air sealing locations, materials or techniques. Other code provisions may be applicable as well.

Air sealing key points *continued*

Multifamily Mechanical Closet

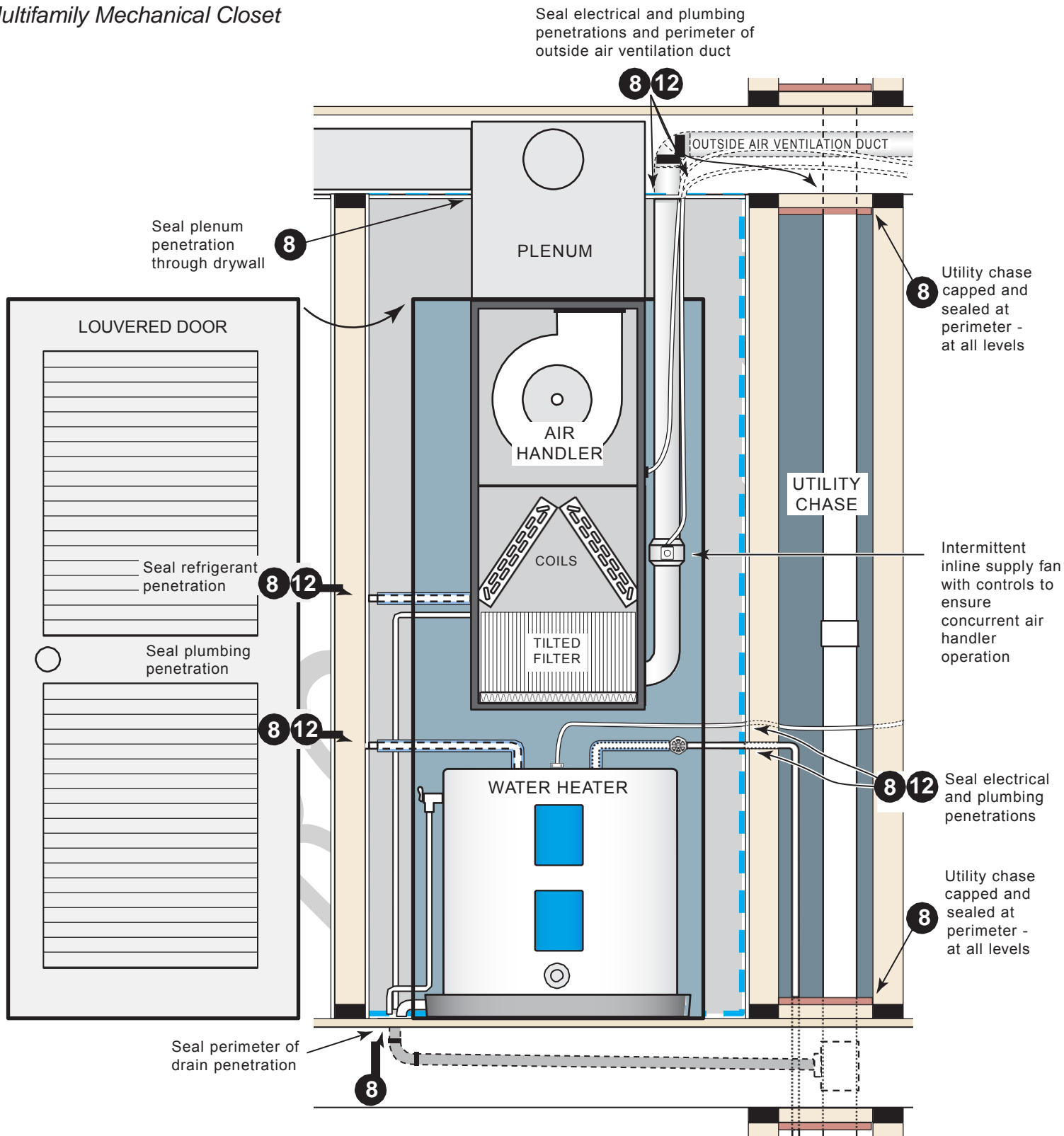

Disclaimer:
This document was created by Southface and is intended solely to help graphically demonstrate the air leakage and insulation provisions of the 2015 IECC (2019 Georgia Energy Code). It does not cover all air sealing locations, materials or techniques. Other code provisions may be applicable as well.

Building Thermal Envelope

— The basement walls, exterior walls, floor, roof, and any other building element that enclose conditioned space. This boundary also includes the boundary between conditioned space and any exempt or unconditioned space. —2015 IECC

The *building thermal envelope* is the barrier that separates the conditioned space from the outside or unconditioned spaces. The building envelope consists of two parts - an air barrier and a thermal barrier that must be both continuous and contiguous (touching each other). In a typical residence, the building envelope consists of the roof, walls, windows, doors, and foundation. Examples of unconditioned spaces include attics, vented crawlspaces, garages, and basements with ceiling insulation and no HVAC supply registers.

Example 1 – Prescriptive Compliance

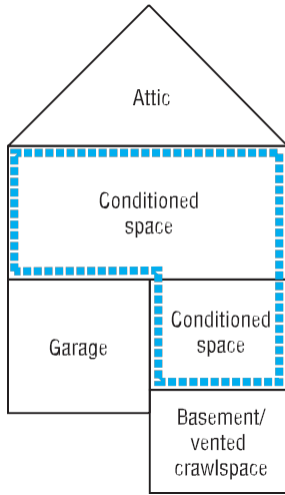

This is a conventional approach that likely locates all ductwork in unconditioned spaces.

Prescriptive R-values

- Flat ceiling: R-38
- Exterior walls: R-13
- Floor over garage and basement/crawl: R-19 (climate zones 3 & 4)
- Ductwork sealed with mastic and insulated to R-8 in attic, R-6 in basement/crawlspace
- Garage⁵, attic and basement/crawl are unconditioned spaces

Example 2 – Alternate Compliance

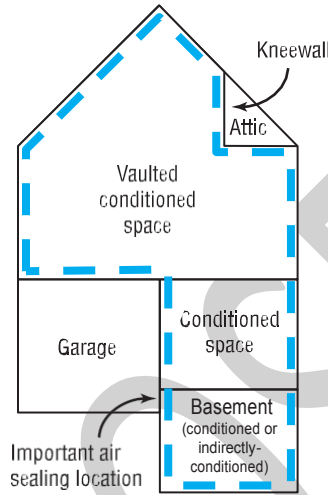

If supply registers deliver conditioned air to basement, it is considered conditioned. With no supply air, it is considered an indirectly-conditioned space.

Example R-values¹

- Flat ceiling: R-38
- Kneewalls: R-18 (required)² (R-13+ R-5, R-15 + R-3, R-19 in 2x6)
- Vaulted ceiling: R-20 air-permeable insulation plus R-5 rigid foam board³
- Exterior walls: R-13
- Basement masonry walls: R-5
- Basement slab: R-0⁴
- Ductwork sealed with mastic and insulated to R-8 in attic, R-6 in basement
- Garage⁵ and attic are unconditioned spaces

Example 3 – Alternate Compliance

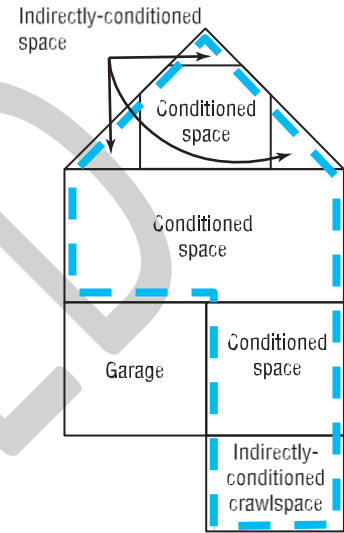

The top conditioned floor functions as a vaulted ceiling with interior walls although it appears to have kneewalls and a flat ceiling. An advantage of this approach is that all upstairs ductwork is located inside the building envelope.

The crawlspace walls are insulated and do not contain vents. The crawlspace ground is covered with 100% plastic and functions as a “mini-basement.”

Example R-values¹

- Vaulted ceiling: R-20 air-impermeable foam insulation³
- Exterior walls: R-13 + R-5 sheathing
- Crawlspace walls: R-5
- Ductwork sealed with mastic and insulated to R-6
- Garage⁵ is unconditioned space

1 R-values shown are examples and not necessarily prescriptive code requirements. Refer to the Georgia Energy Code for specific prescriptive insulation requirements.

2 An attic kneewall is any vertical wall that separates conditioned space from an unconditioned attic. In Georgia, kneewalls must be insulated to R-18. A sealed attic-side air barrier (OSB, foil-faced sheathing, etc.) is required when using air permeable insulation.

3 Requires trade-off since prescriptive ceiling requirement is R-38, see roofline installed insulation options and section 806.5 of the 2012 IRC.

4 Slab insulation is not required in Georgia due to termite risk.

5 Although there is nothing to prevent the garage walls from being insulated, due to indoor air quality concerns, the garage should never be considered inside the building

Disclaimer:
This document was created by Southface and is intended solely to help graphically demonstrate the air leakage and insulation provisions of the 2015 IECC (2019 Georgia Energy Code). It does not cover all air sealing locations, materials or techniques. Other code provisions may be applicable as well.

Insulation Details for Ceilings with Attic spaces

Rafter and Truss

Standard Truss
with tapered
insulation depth

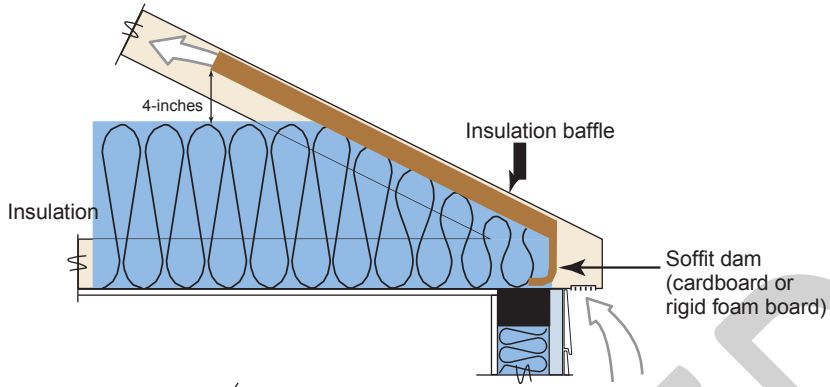

Note: Wind wash baffle and air-permeable insulation dam. For air permeable insulation in vented attics, baffles shall be installed adjacent to soffit and eave vents. A minimum of a 1-inch of space shall be provided between the insulation and the roof sheathing and at the location of the vent. The baffle shall extend over the top of the insulation inward until it is at least 4 inches vertically above the top of the insulation. Any solid material such as cardboard or thin insulating sheathing shall be permissible as the baffle.

Energy Truss
with full height insulation
(recommended)

NOTE:
R-30 complete coverage
is deemed equivalent to
prescriptive R-38

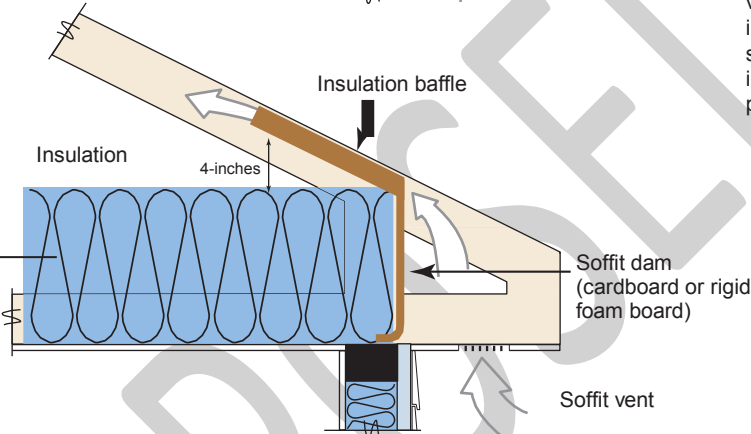

Standard rafter and top plate
with tapered
insulation depth

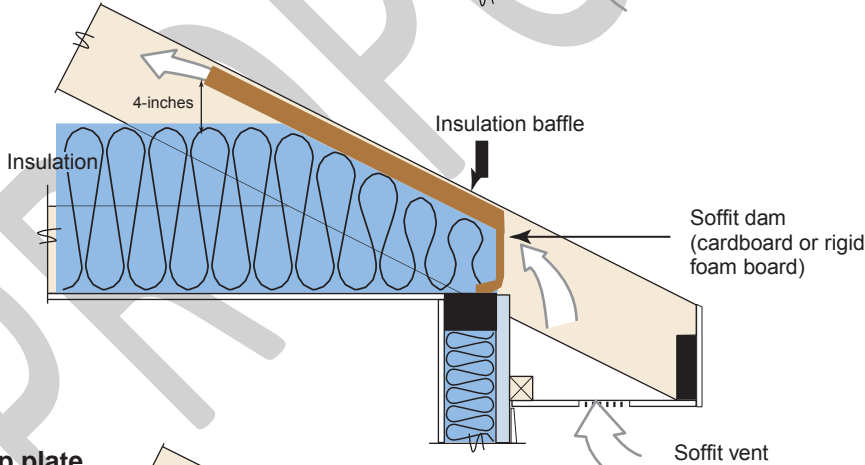

Rafter on raised top plate
with full height insulation
(recommended)

NOTE:
R-30 complete coverage
is deemed equivalent to
prescriptive R-38

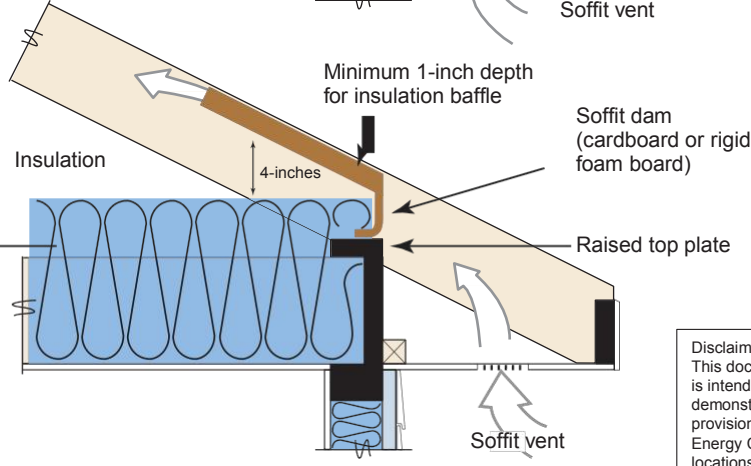

Disclaimer:
This document was created by Southface and is intended solely to help graphically demonstrate the air leakage and insulation provisions of the 2015 IECC (2019 Georgia Energy Code). It does not cover all air sealing locations, materials or techniques. Other code provisions may be applicable as well.

Roofline Installed Insulation Options

Reference Table 402.1.1 and 402.1.6 in the Georgia Energy Code amendments to the 2015 IECC and Section 806.5 "unvented attic assemblies" in the Georgia Amendments to the 2012 IRC

Vaulted unvented attic – roofline air-impermeable insulation (e.g., spray foam insulation)

Air impermeable insulation
(e.g., open- or closed-
cell spray foam)

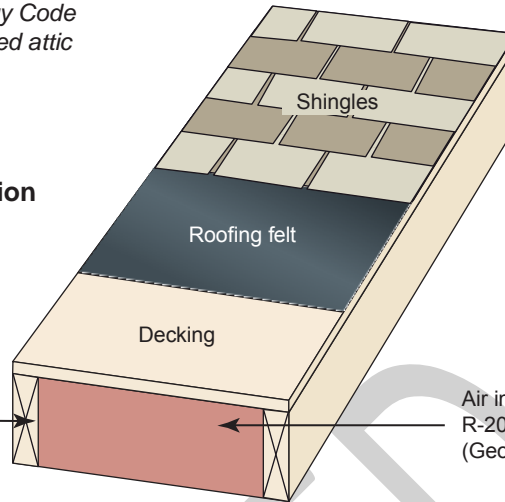

Air impermeable insulation
R-20 minimum if trade-offs are used
(Georgia requirements)

Vaulted unvented attic – roofline air-permeable insulation (e.g., fiberglass, cellulose insulation)

Air impermeable
insulation
(e.g. rigid foam board)

Option 1

Air impermeable
insulation continuous above
rafters (e.g. rigid foam board)
combined with air-permeable
insulation
(e.g., fiberglass,
cellulose insulation)

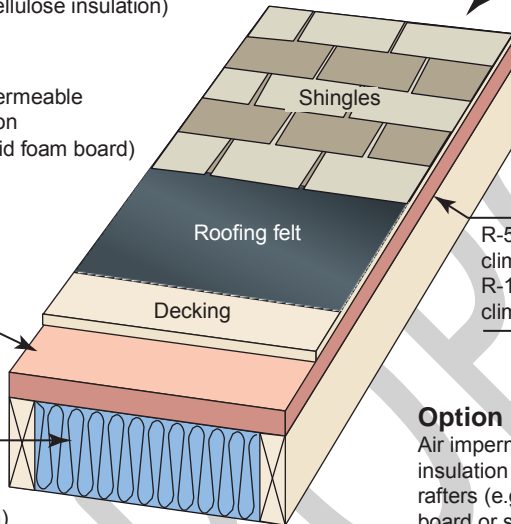

R-5 minimum in
climate zones 2 & 3
R-15 minimum in
climate zone 4

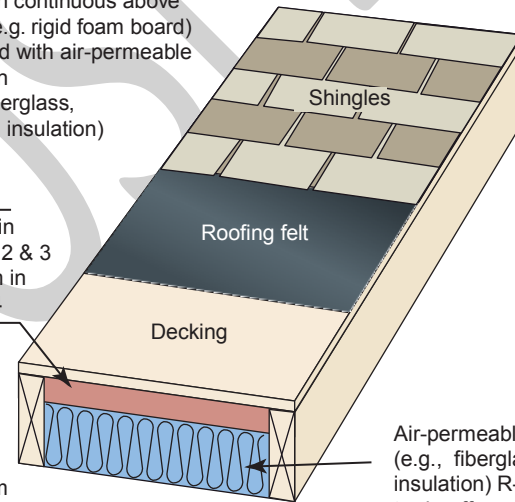

Option 2

Air impermeable
insulation between
rafters (e.g. rigid foam
board or spray foam)
combined with
air-permeable insulation (e.g., fiberglass,
cellulose insulation)

Air-permeable insulation
(e.g., fiberglass, cellulose
insulation) R-20 minimum if
trade-offs are used (Georgia
requirements)

Cathedralized vented ceiling– roofline air-permeable insulation (e.g., fiberglass, cellulose insulation)

Air-permeable insulation
(e.g., fiberglass, cellulose
insulation) R-20 minimum if
trade-offs are used
(Georgia requirements)

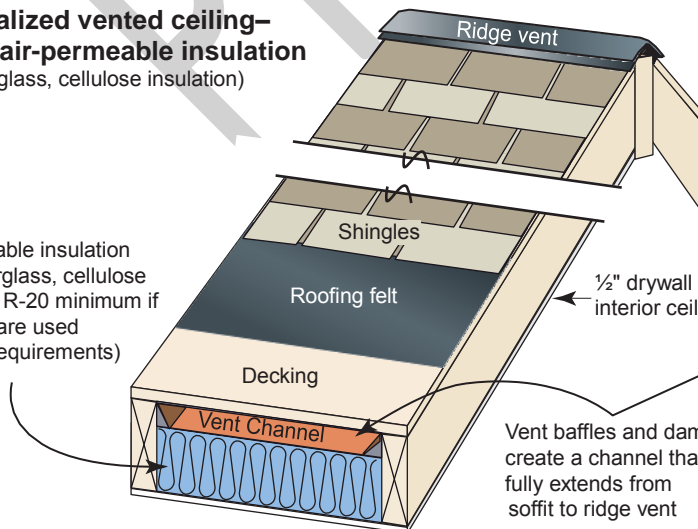

Vent baffles and
dams create a channel that
fully extends from
soffit to ridge vent

Air-permeable insulation
(e.g., fiberglass, cellulose
insulation) R-20 minimum if
trade-offs are used
(Georgia requirements)

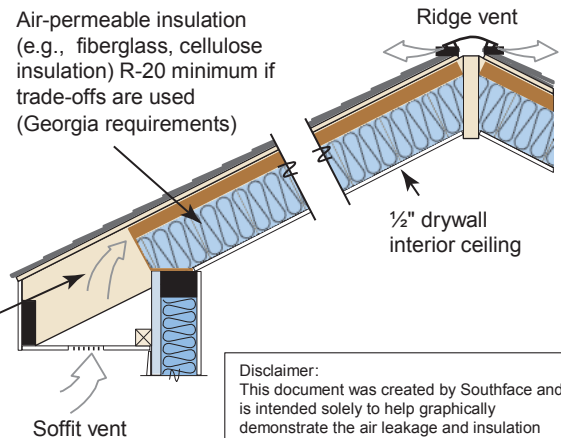

Soffit vent

Disclaimer:
This document was created by Southface and
is intended solely to help graphically
demonstrate the air leakage and insulation
provisions of the 2015 IECC (2019 Georgia
Energy Code). It does not cover all air sealing
locations, materials or techniques. Other code
provisions may be applicable as well.

Georgia Insulation Installation – *Passing Grade Details*

Wall and ceiling insulation that makes up portions of the building thermal envelope shall be installed to Passing Grade quality.

Two criteria affect installed insulation grading: **voids/gaps** (in which no insulation is present in a portion of the overall insulated surface) and **compression/incomplete fill** (in which the insulation does not fully fill out or extend to the desired depth).

Voids/Gaps

- Voids or gaps in the insulation are < 1% of overall component surface area (only occasional and very small gaps allowed for Passing Grade)

Compression/Incomplete Fill

- Compression/Incomplete Fill for both *air permeable insulation* (e.g., fiberglass, cellulose) and *air impermeable insulation* (e.g., spray polyurethane foam) must be less than 1 inch in depth or less than 30% of the intended depth, whichever is more stringent. The allowable area of compression/incomplete fill must be less than 2% of the overall insulated surface to achieve a Passing Grade.
- Any compression/incomplete fill with a **depth** greater than the above specifications (up to 1" or 30% of the intended depth, whichever is more stringent) shall not achieve a Passing Grade.

Additional Wall Insulation Requirements

- All vertical air permeable insulation shall be installed in substantial contact with an air barrier on all six (6) sides.
Exception: Unfinished basements, rim/band joist cavity insulation and fireplaces (insulation shall be restrained to stay in place).
For unfinished basements, air permeable insulation and associated framing in a framed cavity wall shall be installed less than ¼" from the basement wall surface.
- Attic knee wall details – Attic knee walls shall be insulated to a total R-value of at least R-18 through any combination of cavity and continuous insulation. Air permeable insulation shall be installed with a fully sealed attic-side air barrier (e.g., OSB with seams caulked, rigid insulation with joints taped, etc.). Attic knee walls with air impermeable insulation shall not require an additional attic-side air barrier.

Underfloor insulation that makes up portions of the building thermal envelope shall be installed to Passing Grade quality.

Two criteria affect installed insulation grading: **voids/ gaps** (in which no insulation is present in a portion of the overall insulated surface) and **compression/incomplete fill** (in which the insulation does not fully fill out or extend to the desired depth).

Voids/Gaps

- Voids or gaps in the insulation are minimal for Passing Grade (< 2% of overall component surface area)

Compression/Incomplete Fill

- Compression/Incomplete Fill for both *air permeable insulation* (e.g., fiberglass, cellulose) and *air impermeable insulation* (e.g., spray polyurethane foam) must be less than 1 inch in depth or less than 30% of the intended depth, whichever is more stringent. The allowable area of compression/incomplete fill must be less than 10% of the overall insulated surface to achieve a Passing Grade.
- Any compression/incomplete fill with a **depth** greater than the above specifications (up to 1" or 30% of the intended depth, whichever is more stringent) shall not achieve a Passing Grade.
- Air-permeable underfloor insulation shall be permanently installed against the subfloor decking. Adequate insulation supports (e.g., wire staves) for air permeable insulation shall be installed at least every 18-24".
Exception: The floor framing-cavity insulation shall be permitted to be in contact with the topside of sheathing or continuous insulation installed on the bottom side of floor framing where combined with insulation that meets or exceeds the minimum wood frame wall R-value and that extends from the bottom to the top of all perimeter floor framing members.

Disclaimer:
This document was created by Southface and is intended solely to help graphically demonstrate the air leakage and insulation provisions of the 2015 IECC (2019 Georgia Energy Code). It does not cover all air sealing locations, materials or techniques. Other code provisions may be applicable as well.

Wall Insulation key points

Voids / Gaps

Passing Grade 

Insulation is notched and completely surrounds electrical box

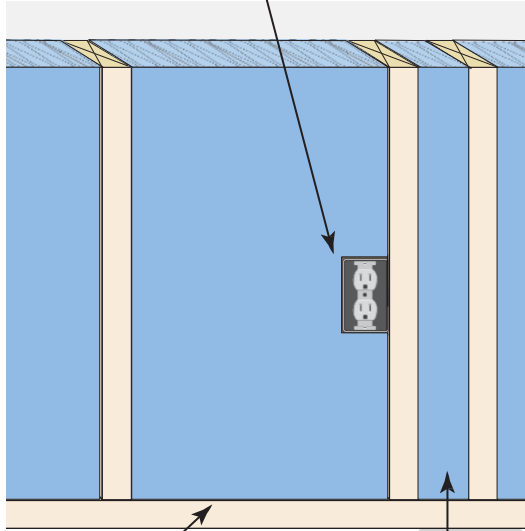

Insulation fully fills cavity at top and bottom

Narrow cavity fully insulated

Unacceptable Installation 

Incomplete insulation coverage around electrical box

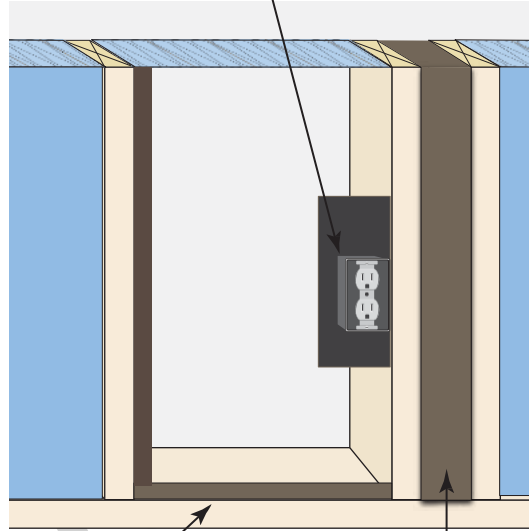

Insulation does not extend to bottom of cavity

Narrow cavity not insulated

Compression / Incomplete Fill

Passing Grade 

Insulation is slit around electrical wire

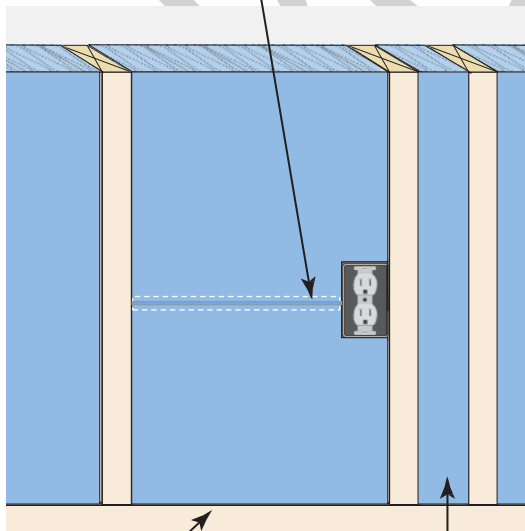

Insulation extends from front to back and fully fills entire cavity

Proper width insulation fully fills narrow cavity

Unacceptable Installation 

Insulation is compressed behind electrical wire

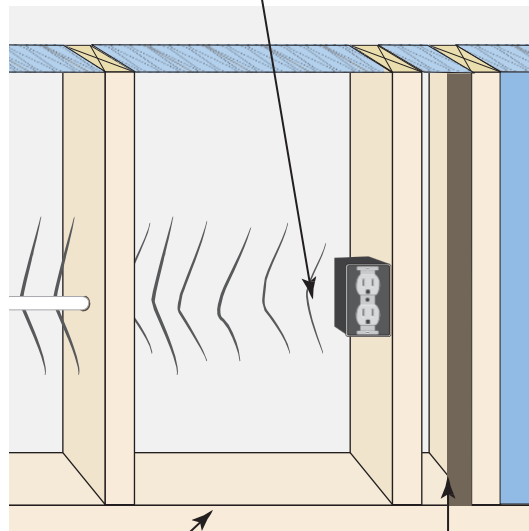

Insulation does not fully fill entire cavity

Improper width insulation is compressed into narrow cavity

Disclaimer:
This document was created by Southface and is intended solely to help graphically demonstrate the air leakage and insulation provisions of the 2015 IECC (2019 Georgia Energy Code). It does not cover all air sealing locations, materials or techniques. Other code provisions may be applicable as well.

Ceiling Insulation key points

Passing Grade 

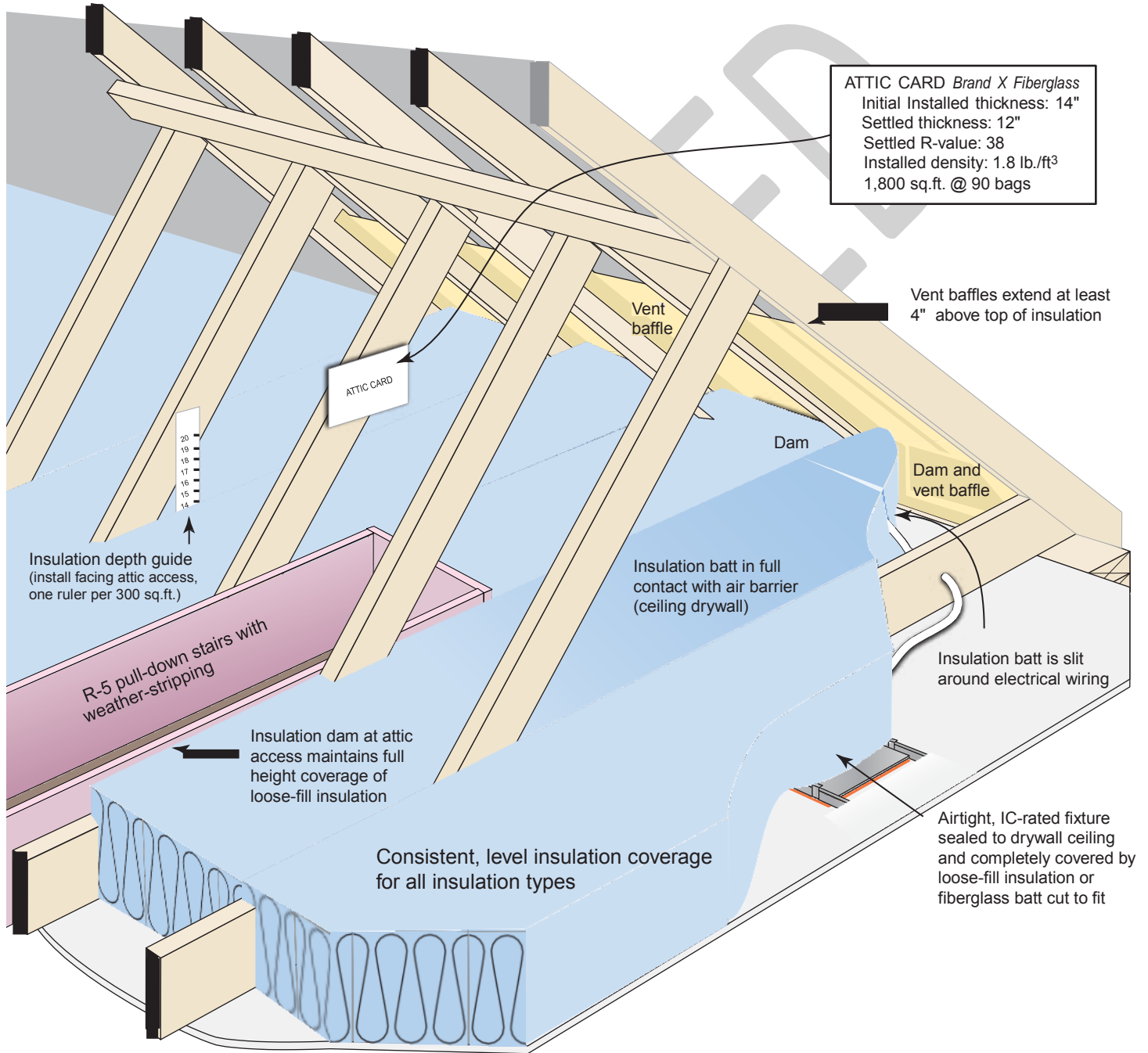

Disclaimer:
This document was created by Southface and is intended solely to help graphically demonstrate the air leakage and insulation provisions of the 2015 IECC (2019 Georgia Energy Code). It does not cover all air sealing locations, materials or techniques. Other code provisions may be applicable as well.

Ceiling Insulation key points

Unacceptable installation 

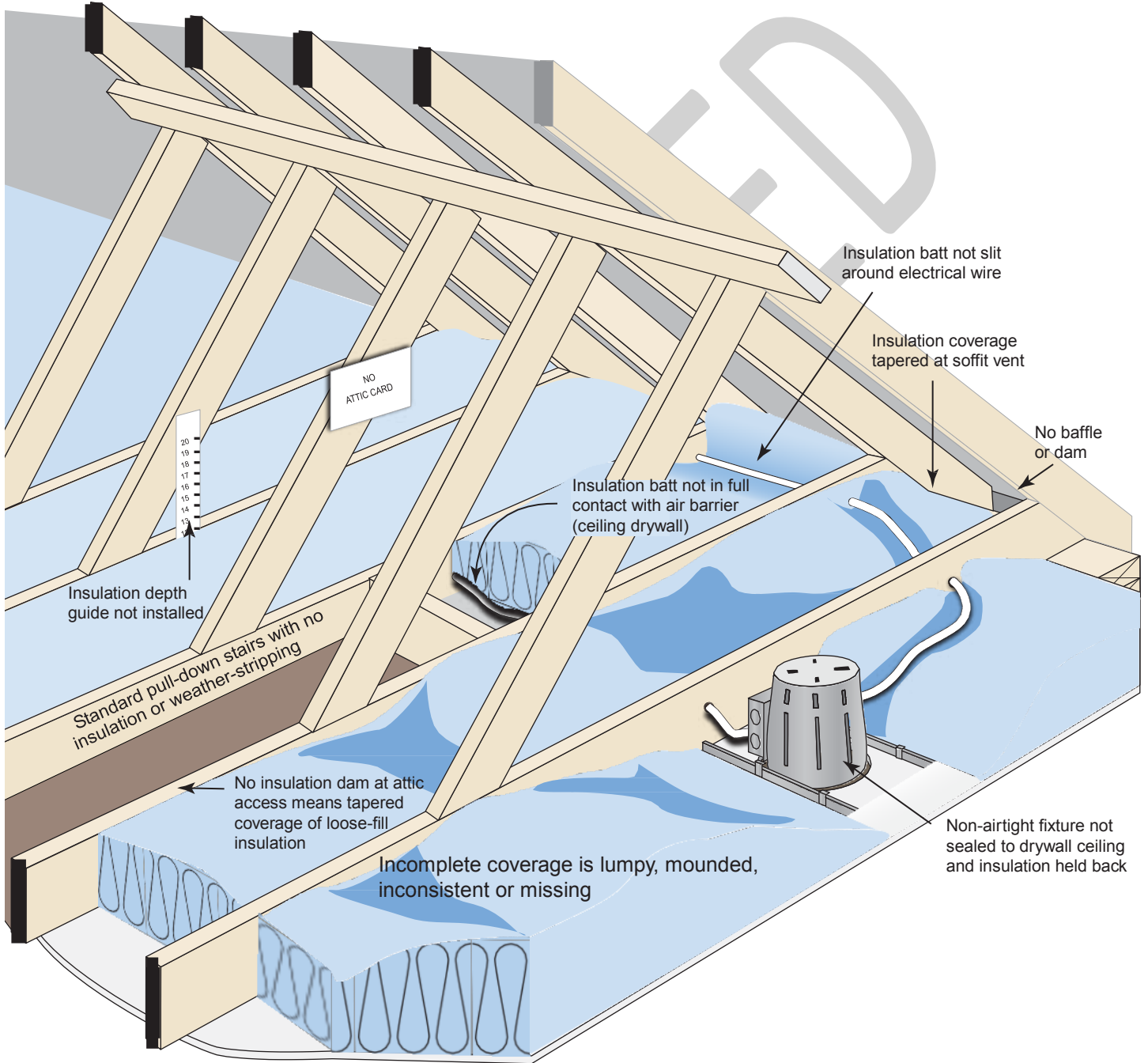

Disclaimer:
This document was created by Southface and is intended solely to help graphically demonstrate the air leakage and insulation provisions of the 2015 IECC (2019 Georgia Energy Code). It does not cover all air sealing locations, materials or techniques. Other code provisions may be applicable as well.

Floor Insulation key points

Passing Grade

Installed insulation is in complete contact with air barrier (subfloor)

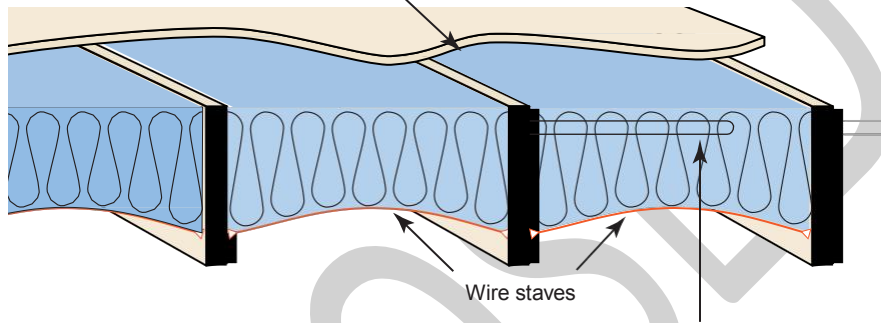

Insulation coverage is complete

Insulation is slit around plumbing and wiring and securely fastened with minimal compression

Unacceptable Installation

Insulation is not installed in complete contact with air barrier (subfloor)

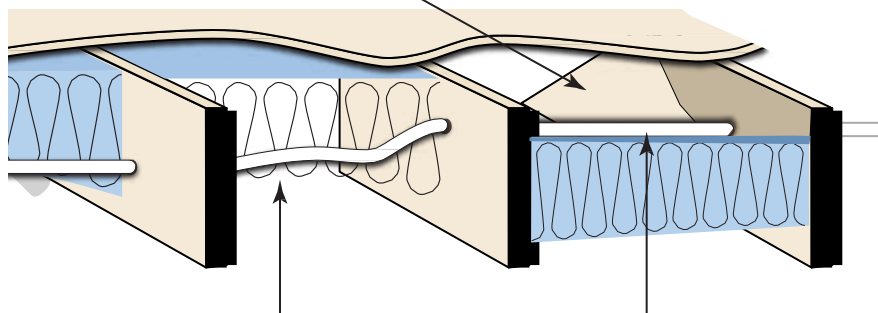

Insulation coverage is incomplete due to obstructions (plumbing, electrical, ductwork, etc.)

Insulation is compressed around plumbing and wiring and is not securely fastened

Disclaimer:
This document was created by Southface and is intended solely to help graphically demonstrate the air leakage and insulation provisions of the 2015 IECC (2019 Georgia Energy Code). It does not cover all air sealing locations, materials or techniques. Other code provisions may be applicable as well.

**APPENDIX RC
THIRD PARTY VERIFICATION**

**SECTION RC101
GENERAL**

RC101.1 Scope. The provisions of this appendix govern the requirements for third-party verification of this code.

RC101.2 Adoption. The authority having jurisdiction may adopt this appendix to utilize third-party verification of this code.

**SECTION RC102
DEFINITIONS**

THIRD-PARTY VERIFIER. An independent person or firm responsible for conducting inspections and/or testing and plan review to verify a project's compliance with the provisions of this code.

**SECTION RC103
QUALIFICATIONS**

RC103.1 General. It shall be the responsibility of the permit holder to retain a qualified *third-party verifier*. The *third-party verifier* shall not be an employee of the owner or builder or have a financial interest in the project.

RC103.2 Residential buildings. Third-party verifiers shall have one of the following minimum qualifications to conduct inspections or plan review for the energy efficiency provisions of *residential buildings* as defined by this code:

1. Accredited HERS Rater
2. ICC Residential Energy Inspector/Plans Examiner Certification
3. EarthCraft House Technical Advisor
4. Building Performance Institute (BPI) Analyst
5. Equivalent qualifications as approved by the local *code official*

Exception: Where the specific provisions of this code require additional qualifications.

RC103.3 Commercial buildings. Third-party verifiers shall have one of the following minimum qualifications to conduct inspections or plan review for the energy efficiency provisions of *commercial buildings* as defined by this code:

1. ICC Commercial Energy Inspector and ICC Commercial Plans Examiner Certifications
2. Equivalent qualifications as approved by the local *code official*

Exception: Where the specific provisions of this code require additional qualifications.

SECTION RC104 INSPECTIONS

RC104.1 General. Construction or work, conducted under the provisions of this code, for which a permit is required shall be subject to inspection by a *third-party verifier*.

RC104.2 Inspection requests. It shall be the duty of the permit holder or their duly authorized agent to notify the *third-party verifier* when work is ready for inspection and to provide access to and means for inspection of such work required by this code.

RC104.3 Fees. The permit holder shall be responsible for all fees charged by the *third-party verifier*.

RC104.4 Residential buildings. A minimum of two inspections shall be conducted for each residential building. The first inspection shall be conducted prior to the closing-up of building cavities; and shall include verification of compliance with the following: insulation, fenestration, air sealing and duct insulation and sealing. The second inspection shall be conducted after the building has been substantially completed and prior to issuance of a certificate of occupancy. The second inspection shall include verification of compliance with any portions of this code not verified during the first inspection.

RC104.5 Commercial buildings. A minimum number of inspections as determined by the *third-party verifier* shall be conducted to ensure verification of compliance with the provisions of Chapter 5 of this code or ASHRAE 90.1.

RC104.6 Re-inspection. A building shall be re-inspected when determined necessary by the *third-party verifier* or local *code official*.

RC104.7 Approval report. Inspection and verification reports shall be submitted by the *third party verifier* to the local *code official*.
(Effective January 1, 2019)

Appendix RD Mandatory Compliance Certificate

2019 Georgia Residential Energy Code Compliance Certificate		Jurisdiction Logo and/or Contact Information Here	
This certificate shall be permanently posted on or in the electrical distribution panel			
Permit# _____			
House Address or Community/Lot# _____			
Building Summary			
Builder Company Name		Signature	Contact (email/phone)
Date			
Compliance Pathway (check one)		Building Envelope (when multiple values per component, list value covering largest area)	
<input type="checkbox"/> Prescriptive: R401-404		Ceiling/Roof R-value	Above-grade mass wall R-value
<input type="checkbox"/> UA Trade-off: R402.1.5		Sloped/vaulted ceiling R-value	Cantilevered floors R-value
<input type="checkbox"/> RESCheck: Keyed to 2015 IECC		Exterior wall R-value	Window/Glass Door SHGC
<input type="checkbox"/> Simulated Performance: R405		Kneewall (cavity and/or continuous) R-value	Window/Glass Door U-factor
<input type="checkbox"/> Energy Rating Index (ERI): R406		Foundation (cavity and/or continuous) R-value	Skylight SHGC
ERI Score		Floors over unconditioned R-value	Skylight U-factor
Mechanical Summary			
HVAC Company Name		Contact (email/phone)	Date
Heating System Type	Efficiency (AFUE, HSPF, COP or other)	Cooling System Type	Efficiency (SEER, EER or other)
Water Heating Type	Efficiency (EF or other)		
<input type="checkbox"/> Gas		<input type="checkbox"/> Air conditioner	
<input type="checkbox"/> Heat pump		<input type="checkbox"/> Heat pump	
<input type="checkbox"/> Other		<input type="checkbox"/> Other:	
<input type="checkbox"/> Gas		<input type="checkbox"/> Gas	
<input type="checkbox"/> Electric		<input type="checkbox"/> Electric	
<input type="checkbox"/> Other:		<input type="checkbox"/> Other:	
<input type="checkbox"/> Yes	<input type="checkbox"/> No	Manual J, S, D or equivalent complete?	
Required Mechanical Ventilation			
Type (check one)	Design Rate (check one)		
<input type="checkbox"/> Exhaust	<input type="checkbox"/> Continuous	Design Ventilation Rate (CFM)	
<input type="checkbox"/> Supply	<input type="checkbox"/> Intermittent		
<input type="checkbox"/> Balanced	if intermittent, list runtime in min. per hour _____		
Duct and Envelope Tightness Testing Summary			
DET Verifier	Contact (email/phone)	DET Verifier ID	
Envelope Tightness Testing (< 5 ACH50) (Envelope Tightness = Blower Door Fan Flow x 60 / Thermal Envelope Volume)			
Blower Door Fan Flow (CFM50)	Thermal Envelope Volume (ft ³)	Envelope Tightness (ACH50)	
If multifamily unit and conducting sampling, this unit is not required to be tested. Mark N/A.			
Duct Tightness Testing (< 4 CFM25/100 ft²) (Total Duct Leakage = 100 x Fan Flow / Area Served)			
Number of Heating and Cooling Systems			
Duct Tightness Leakage Test Results	System 1	System 2	System 3
If air handler and ductwork located entirely within in conditioned space, testing not required. Mark N/A.			
Location			
Fan Flow (CFM25)			
Area Served (ft ²)			
Total Duct Leakage (CFM25/100 ft ²)			
Rough In Total (RIT) or Post Construction Total (PCT)			

Version 1.0

Georgia State Amendments to the International Building Code (2018 Edition)



Georgia Department of Community Affairs
Local Government Assistance Division
60 Executive Park South, N.E.
Atlanta, Georgia 30329-2231
(404) 679-3118
www.dca.ga.gov

Revised January 1, 2020

**GEORGIA STATE MINIMUM STANDARD BUILDING CODE
(INTERNATIONAL BUILDING CODE WITH GEORGIA STATE AMENDMENTS)**

The **INTERNATIONAL BUILDING CODE, 2018 Edition**, published by the International Code Council, when used in conjunction with these Georgia State Amendments, shall constitute the official *Georgia State Minimum Standard Building Code*.

GEORGIA STATE AMENDMENTS

CODE REFERENCE:

- (a) Replace all references to the ICC *Electrical Code* with references to the *Georgia State Minimum Standard Electrical Code (National Electrical Code with Georgia State Amendments)*.
- (b) Replace all references to the *International Energy Conservation Code (IECC)* with references to the *Georgia State Minimum Standard Energy Code (IECC with Georgia State Supplements and Amendments)*. The *Georgia State Minimum Standard Energy Code* shall be used for efficiency and coefficient of performance ratings of equipment.
- (c) Replace all references to the *International Existing Building Code (IEBC)* with references to Chapter 34 'Existing Buildings' of these Georgia State Amendments.

Note: By Georgia law, the *International Existing Building Code* is a permissive or optional State Minimum Standard Code. Consequently, the provisions contained in the *International Existing Building Code* are not mandatory or applicable unless specifically referenced in the adopting ordinance of local governments.

APPENDICES:

Appendices are not enforceable unless they are specifically referenced in the body of the code or adopted by the Department of Community Affairs or the authority having jurisdiction.

SCOPE:

The provisions of the *Georgia State Minimum Standard Building Code* shall apply to the construction, *alteration*, relocation, enlargement, replacement, *repair*, equipment, use and occupancy, location, maintenance, removal and demolition of every building or structure or any appurtenances connected or attached to such buildings or structures.

Exception #1: Detached one- and two-family *dwelling*s and multiple single-family *dwelling*s (townhouses separated by a 2-hour fire-resistance-rated wall assembly) not more than three *stories* above *grade plane* in height with a separate *means of egress* and their accessory structures shall comply with the *Georgia State Minimum Standard One and Two Family Dwelling Code (International Residential Code for One- and Two-Family Dwellings with Georgia State Amendments)*.

Exception #2: The following table titled 'Codes Reference Guide' establishes specific primary and supplementary code applications and is to be applied by the authority having jurisdiction.

CODES REFERENCE GUIDE

Area	Primary	Supplement
Occupancy Classification	LSC	IBC
Building Construction Types including allowable height, allowable building areas, and the requirements for sprinkler protection related to minimum building construction types.	IBC	LSC
Means of Egress	LSC	NONE
Standpipes	IBC	IFC
Interior Finish	LSC	NONE
HVAC Systems	IMC	NONE
Vertical Openings	LSC	NONE
Sprinkler Systems minimum construction standard	LSC	NONE
Fire Alarm Systems	LSC	NONE
Smoke Alarms and Smoke Detection Systems	State Statute and LSC	NONE
Portable Fire Extinguishers	IFC	NONE
Cooking Equipment	LSC and NFPA 96	NONE
Fuel Fired Appliances	IFGC	NFPA 54
Liquid Petroleum Gas	NFPA 58	NFPA 54
Compressed Natural Gas	NFPA 52	NONE

**Revise the International Building Code, 2018 Edition, to read as follows:*

**CHAPTER 1
SCOPE AND ADMINISTRATION**

*Delete Chapter 1 ‘Scope and Administration’ entirely without substitution. Chapter 1 to remain in the Code as a reference guide for local governments to use in development of their own *Administrative Procedures*.
(Effective January 1, 2020)

**CHAPTER 2
DEFINITIONS**

**SECTION 202
DEFINITIONS**

*Add definition of ‘Elevator Door Opening Protective Device’ to read as follows:

ELEVATOR DOOR OPENING PROTECTIVE DEVICE. Any device that either independently or in conjunction with the (elevator) door assembly allows the device(s) to meet the requirements of Sections 716.5.3 716, 716.2.2.1 and 3008.6.3.
(Effective January 1, 2020)

**CHAPTER 3
OCCUPANCY AND USE CLASSIFICATION**

**SECTION 308
INSTITUTIONAL GROUP I**

*Add a new Section 308.3.3 ‘Assisted living communities’ to read as follows:

308.3.3 Assisted living communities. Assisted living communities, licensed by the State, housing twenty-five or more persons, meeting the Georgia State Fire Marshal’s Office Life Safety Code requirements shall be deemed as equivalent compliance to the *International Building Code* Chapters 3, 4, 8, 9, and 10.
(Effective January 1, 2020)

**CHAPTER 4
SPECIAL DETAILED REQUIREMENTS BASED ON USE AND OCCUPANCY**

**SECTION 415
GROUPS H-1, H-2, H-3, H-4 AND H-5**

*Revise Section [F] 415.9.2 ‘Liquefied petroleum gas facilities’ to read as follows:

[F] 415.9.2 Liquefied petroleum gas facilities. The construction and installation of liquefied petroleum gas facilities shall be in accordance with the requirements of this code, the *International Mechanical Code*, NFPA 58 and NFPA 54 as adopted by the Rules and Regulations of the Safety Fire Commissioner Chapter 120-3-16, “*Rules and Regulations for Liquefied Petroleum Gases*”.
(Effective January 1, 2020)

**CHAPTER 5
GENERAL BUILDING HEIGHTS AND AREAS**

**SECTION 504
BUILDING HEIGHT AND NUMBER OF STORIES**

*Revise Table 504.4 ‘Allowable Number of Stories Above Grade Plane^{a,b}’ for the Occupancy Classification “I-1 Condition 2” as shown and add a new footnote “i” to read as follows:

**TABLE 504.4
ALLOWABLE NUMBER OF STORIES ABOVE GRADE PLANE^{a, b}**

OCCUPANCY CLASSIFICATION	TYPE OF CONSTRUCTION									
	SEE FOOTNOTES	TYPE I		TYPE II		TYPE III		TYPE IV	TYPE V	
		A	B	A	B	A	B	HT	A	B
I-1 Condition 2	NS ^{d, e}	NP	NP	NP	NP	NP	NP	NP	NP	NP
	S ⁱ	UL	10	3	2	2	1	2	2	1

i. For all I-1 Condition 2, the building shall be protected throughout with an approved automatic sprinkler system, installed in accordance with NFPA 13 as adopted by the Rules and Regulations of the Safety Fire Commissioner. No increase in story height shall be permitted.

(Remainder of table unchanged)
(Effective January 1, 2020)

**CHAPTER 7
FIRE AND SMOKE PROTECTION FEATURES**

**SECTION 706
FIRE WALLS**

*Revise Section 706.2 ‘Structural stability’ to read as follows:

706.2 Structural stability. *Fire walls* shall be designed and constructed to allow collapse of construction on either side without collapse of the wall under fire conditions and loading per Section 1607.15.2. *Fire walls* designed and constructed in accordance with NFPA 221 shall be deemed to comply with this section.

Exception: In Seismic Design Categories D through F, where double *fire walls* are used in accordance with NFPA 221, floor and roof sheathing not exceeding 3/4 inch (19.05 mm) thickness shall be permitted to be continuous through the wall assemblies of light frame construction.

(Effective January 1, 2020)

*Delete Exception to Section 706.3 ‘Materials’ without substitution.
(Effective January 1, 2020)

**SECTION 713
SHAFT ENCLOSURES**

*Add new Section 713.14.1 ‘Designated floor lobbies for elevator return’ to read as follows:

713.14.1 Designated floor lobbies for elevator return. New elevators, escalators, dumbwaiters, and moving walks shall be installed in accordance with the requirements of ASME A17.1, Safety Code for Elevators and Escalators. The designated elevator lobby of the

designated floor and the designated alternate floor specified by ASME A17.1 Section 2.27.3 shall be separated from the remainder of the building by 1-hour fire-rated construction. In buildings equipped with automatic sprinkler protection, smoke partitions in accordance with the 'Rules and Regulations of the Safety Fire Commissioner Chapter 120-3-3 Rules and Regulations for the State Minimum Fire Safety Standards' may be used in lieu of 1-hour fire-rated construction. Except health care occupancies, openings in the elevator lobby shall be limited to those required for access to the elevators from exit access corridors only. Elevator lobbies may be used as part of the means of egress from the building.

Exceptions:

1. Designated floor elevator lobbies are not required within an atrium.
 2. Designated floor elevator lobbies are not required where elevators are installed on open exterior walls.
 3. Designated floor elevator lobbies are not required where elevators are installed in open air parking structures.
 4. Designated floor elevator lobbies are not required in buildings three stories or less with vertical openings protected in accordance with the applicable occupancy chapter.
 5. Existing installations acceptable to the authority having jurisdiction.
 6. For existing buildings or existing structures, reference Section 3401.7 (GA Amendments).
- (Effective January 1, 2020)

**CHAPTER 9
FIRE PROTECTION AND LIFE SAFETY SYSTEMS**

**SECTION 903
AUTOMATIC SPRINKLER SYSTEMS**

*Revise Section [F] 903.2.8 'Group R' to add exception to read as follows:

[F] 903.2.8 Group R.

Exception: Group R-1 and R-2 occupancies which meet the exceptions allowed by the Rules and Regulations of the Safety Fire Commissioner Chapter 120-3-3 'Rules and Regulations for the State Minimum Fire Safety Standards' are exempt from this requirement.
(Effective January 1, 2020)

*Revise Section [F] 903.2.8.1 'Group R-3' to read as follows:

[F] 903.2.8.1 Group R-3. An *automatic sprinkler system* installed in accordance with Section 903.3.1.2 shall be permitted in Group R-3 occupancies.
(Effective January 1, 2020)

*Revise Section [F] 903.2.8.2 'Group R-4, Condition 1' to read as follows:

[F] 903.2.8.2 Group R-4, Condition 1. An *automatic sprinkler system* installed in accordance with Section 903.3.1.2 shall be permitted in Group R-4, Condition 1 occupancies.
(Effective January 1, 2020)

*Revise Section [F] 903.2.8.4 'Care facilities' to read as follows:

[F] 903.2.8.4 Care facilities. An *automatic sprinkler system* installed in accordance with Section 903.3.1.2 shall be permitted in care facilities with five or fewer individuals in a single-family dwelling.

(Effective January 1, 2020)

*Revise Section [F] 903.3.1.3 ‘NFPA 13D sprinkler systems’ to read as follows:

[F] 903.3.1.3 NFPA 13D sprinkler systems. *Automatic sprinkler systems* installed in one- and two-family *dwellings*; and *townhouses* separated by 2 hour firewalls shall be permitted to be installed throughout in accordance with NFPA 13D.

(Effective January 1, 2020)

SECTION 909 SMOKE CONTROL SYSTEMS

*Delete Section 909.21.1 ‘Pressurization requirements’ entirely and substitute to read as follows:

909.21.1 Pressurization requirements. The system shall be designed such that the maximum pressure differential shall not restrict or prohibit the free operation of the elevated cab and all hoistway doors serving all levels of the building. The air shall not be introduced into the hoistway in such a manner as to cause erratic operation by impingement of traveling cables, selector tapes, governor ropes, compensating ropes, and other components sensitive to excessive movement or deflection.

Exception: In existing buildings, when testing existing elevator pressurization systems, they shall be certified to ensure a minimum positive pressure, subject to the approval of the authority having jurisdiction. This pressure shall be measured at the midpoint of each hoistway door, with all elevator cars at the floor of recall and all hoistway doors on the floor of recall open and all other hoistway doors closed. The opening and closing of hoistway doors at each level must be demonstrated during this test. The supply air intake shall be from an outside, uncontaminated source.

(Effective January 1, 2020)

CHAPTER 11 ACCESSIBILITY

*Delete Chapter 11 ‘Accessibility’ entirely without substitution.

{Cross-reference in State law: Title 30, Chapter 3 of the Official Code of Georgia Annotated (O.C.G.A) and the Rules and Regulations of the Georgia Safety Fire Commissioner.}

(Effective January 1, 2020)

**CHAPTER 14
EXTERIOR WALLS**

**SECTION 1404
INSTALLATION OF WALL COVERINGS**

*Add new Section [BS] 1404.19 ‘Installation of wall coverings’ to read as follows:

[BS] 1404.19 Installation of wall coverings. Except masonry veneer, wall cladding shall be installed a minimum of 6 inches above the finished earth grade, or a minimum of 2 inches above paved areas to provide a clear, visible inspection gap.
(Effective January 1, 2020)

**CHAPTER 17
SPECIAL INSPECTIONS AND TESTS**

**SECTION 1701
GENERAL**

*Add new Section 1701.2 ‘Construction documents’ to read as follows:

1701.2 Construction documents. The *construction documents* for special inspections shall include:

1. The statement of special inspections in accordance with Section 1704.3.
2. The following statement:
“Special inspection reports and a final report in accordance with Section 1704.2.4 shall be submitted to the building official prior to the time that phase of the work is approved for occupancy.”

(Effective January 1, 2020)

*Add new Section 1701.3 ‘Guidelines’ to read as follows:

1701.3 Guidelines. The local building official or authority having jurisdiction shall be authorized to use ACEC/SEAOG SI GL 01, Georgia Special Inspections Guidelines, in part or in whole for the purposes of implementing and enforcing the provisions of Chapter 17, ‘Special Inspections and Tests’, and/or establishing a Special Inspections program for their jurisdiction.
(Effective January 1, 2020)

SECTION 1704
SPECIAL INSPECTIONS AND TESTS,
CONTRACTOR RESPONSIBILITY AND
STRUCTURAL OBSERVATION

*Revise Section 1704.2 ‘Special inspections and tests’ to read as follows:

1704.2 Special inspections and tests. Where application is made to the *building official* for construction as described in this section, the owner or the *registered design professional in responsible charge* acting as the owner’s agent, other than the contractor, shall employ one or more *approved agencies* to provide *special inspections* and tests during construction on the types of work specified in Section 1705. These inspections are in addition to the inspections by the *building official* identified in Section 110.

Exceptions:

1. *Special inspections* are not required for construction of a minor nature that does not require the practice of professional engineering or architecture, as defined by Georgia statutes and regulations governing the professional registration and certification of engineers or architects or as warranted by conditions in the jurisdiction as *approved* by the *building official*.
2. Unless otherwise required by the *building official*, *special inspections* and tests are not required for Group U occupancies that are accessory to a residential occupancy including, but not limited to, those listed in Section 312.1.
3. *Special inspections* and tests are not required for portions of structures designed and constructed in accordance with the cold-formed steel light-frame construction provisions of Section 2211.1.2 or the conventional light-frame construction provisions of Section 2308.

(Effective January 1, 2020)

*Revise Section 1704.2.1 ‘Special inspector qualifications’ to read as follows:

1704.2.1 Special inspector qualifications. The special inspector shall provide written documentation to the *building official* demonstrating his or her competence and relevant experience or training. Experience or training shall be considered relevant when the documented experience or training is related in complexity to the same type of *special inspection* activities for projects of similar complexity and material qualities. The special inspector shall be qualified in accordance with Table 1704.2. These qualifications are in addition to qualifications specified in other sections of this code.

The *registered design professional in responsible charge* and engineers of record involved in the design of the project are permitted to act as the *approved agency* and their personnel are permitted to act as the special inspector for the work designed by them, provided they qualify as special inspectors.

(Effective January 1, 2020)

*Add new Table 1704.2 ‘Minimum Special Inspector Qualifications’ to read as follows:

TABLE 1704.2 MINIMUM SPECIAL INSPECTOR QUALIFICATIONS			
Category of Testing and Inspection	Minimum Qualifications (refer to key at end of Table)		
	Shop Testing or Inspection	Field Testing or Inspection	Review Testing, Certification & Lab Reports
1704.2.5 Inspection of Fabricators			
Pre-cast concrete	A, C, E		
Structural steel construction	C, F, G		
Wood construction	A		
Cold formed metal construction	A		
1705.2, 1705.10, 1705.11 & 1705.12 Steel Construction			
Verification of welding consumables, filler metals, procedure specifications, procedure qualification records and personnel performance qualification records			C, F
Nondestructive testing of welding	G	G	
Inspection of welding	C, F	C, F	
Verification of fabricator and erector documents as listed in AISC 360, chapter N, paragraph 3.2			A, C
Material verification of weld filler materials			C, F
Inspection of high strength bolting and steel frame joint details		A, C	
Inspection of embedment		A, C, F	
Inspection of steel elements of composite construction		A, C, F	
Verification of reinforcing steel, cold formed steel deck and truss materials			A, C, F
Inspection of reinforcing steel, cold formed steel deck and trusses		A, C	
1705.3 & 1705.12 Concrete Construction			
Reinforcing placement, cast-in-place bolts, post installed anchors concrete and shotcrete placement and curing operations. Inspection of formwork for shape, location and dimensions		A, C, H	
Pre-stressing steel installation		A, C, D, E	
Erection of pre-cast concrete members		A, C, H	
Concrete field sampling and field testing		A, J	
Concrete strength testing		P	
Review certified mill reports			A, C
Verify use of required design mix		A, I, J, H, C	
Pre-stressed (pre-tensioned) concrete force application	A, C, E		
Post-tensioned concrete force application		A, C, D	
Review of in-situ concrete strength, prior to stressing of			

TABLE 1704.2 MINIMUM SPECIAL INSPECTOR QUALIFICATIONS

Category of Testing and Inspection	Minimum Qualifications (refer to key at end of Table)		
	Shop Testing or Inspection	Field Testing or Inspection	Review Testing, Certification & Lab Reports
tendons in post-tensioned concrete and prior to removal of shores and forms from beams and structural slabs		A, C, D, H	
Reinforcing steel weldability, reinforcing welding, weld filler material		C, F	
Testing of welding of reinforcing steel		G	
1705.4 Masonry			
Verification of f'_m and f'_{AAC}		A, C, L, M	
Mortar joint construction, grout protection and placement, materials proportion, type/size/location of reinforcement, structural elements, anchorage, and connectors		A, C, K	
Sampling/testing of grout/mortar specimens		A, C, L, M	
Observe preparation of masonry prisms for testing of compressive strength of masonry, f'_m and f'_{AAC}		A, C, K, L, M	
Inspection of welding of reinforcing steel		C, F	
Testing of welding of reinforcing steel		G	
1705.6 & 1804 Soils			
Observe site preparation, fill placement testing of compaction for compliance with the construction documents for the project		A, C, I, N	
Observe test bearing materials below shallow foundations for ability to achieve design bearing capacity		A, C, N, I (Level III)	
Review compaction testing for compliance with the construction documents for the project			A
1705.5, 1705.10, 1705.11 & 1705.12 Wood Construction			
Observe structural panel sheathing, size of framing members, nail or staple diameter and length, number of fastener lines, and spacing of fastener lines and fasteners for compliance with construction documents for the project		A	
Observe temporary and permanent truss member restraint/bracing, field gluing of elements. Observe bolting, anchoring or other fastening of: shear walls, diaphragms, drag struts, braces and hold-downs		A	
1705.7, 1705.8, 1705.9 & 1810 Pile and Pier Foundations			
Observe installation		A, N	
Observe load tests		A	
1705.13 Sprayed Fire-Resistant Materials			
Observe surface conditions, application, average thickness and density of applied material, and cohesive/adhesive bond		A, C	

TABLE 1704.2 MINIMUM SPECIAL INSPECTOR QUALIFICATIONS

Category of Testing and Inspection	Minimum Qualifications (refer to key at end of Table)		
	Shop Testing or Inspection	Field Testing or Inspection	Review Testing, Certification & Lab Reports
1705.14 Mastic and Intumescent Fire-Resistant Coatings			
Observe application compliance with AWCI 12-B		A, C	
1705.15 Exterior Insulation and Finish Systems			
Inspect EIFS systems		A, B, C, O	
1705.1 Special Cases			
Work of unusual or special nature		A, B, O	
1705.16 Fire-Resistant Penetrations and Joints	<i>See Requirements of IBC Sections 1705.16.1 and 1705.16.2</i>		
1705.17 Smoke Control	<i>See Requirements of IBC Section 1705.17.2</i>		
1705.10, 1705.11 & 1705.12 Seismic and Wind Resistance			
Periodic inspection of fabrication, installation and/or anchorage of building systems and components		A	

KEY:

- A. Georgia Professional Engineer (GA PE) competent in the specific task area or graduate of accredited engineering/engineering technology program under the direct supervision of a GA PE.
- B. Georgia Registered Architect (GA RA) or graduate of accredited architecture/architecture technology program under the direction of a GA RA.
- C. International Code Council (ICC) Special Inspector Certification specific to the particular material and testing methodology applicable to each Category of Testing and Inspection listed in the table.
- D. Post-tensioning Institute (PTI) Certification, Level 2, bonded or unbonded as applicable.
- E. Pre-stressed Concrete Institute (PCI) Certified Inspector.
- F. American Welding Society (AWS) Certified Welding Inspector (CWI) or AWS Certified Associate Welding Inspector working under the direct on-site supervision of a CWI.
- G. American Society for Nondestructive Testing (ASNT) Level II certification, or a Level III certification if previously certified as a Level II in the particular material and testing methodology applicable to each Category of Testing and Inspection listed in the table.
- H. American Concrete Institute (ACI) Concrete Construction Special Inspector.
- I. National Institute for Certification in Engineering Technologies (NICET) Level II or higher certification specific to the particular material and testing methodology applicable to each Category of Testing and Inspection listed in the table.
- J. ACI Concrete Field Testing Technician with Grade 1 certification.
- K. Georgia Concrete and Products Association (GC&PA) – Masonry Association of Georgia (MAG) Masonry Construction Inspector Certification.
- L. National Concrete Masonry Association (NCMA) Concrete Masonry Testing Procedures certification.
- M. GC&PA – MAG Masonry Testing Technician certification.
- N. NICET Certified Engineering Technologist (CT).
- O. Other Qualified Special Inspector as approved by the Building Official.
- P. American Concrete Institute (ACI) Strength Testing Technician.

Notes:

1. The Special Inspector shall meet one of the minimum qualifications listed for the applicable Category of Testing and Inspection.
2. Materials testing shall be done by an Approved Testing Agency meeting the requirements of IBC Section 1703 and ASTM E 329.

(Effective January 1, 2020)

*Revise Section 1704.2.4 ‘Report requirement’ to read as follows:

1704.2.4 Report Requirement. *Approved agencies* shall keep records of inspections and tests. The *approved agency* shall submit reports of special inspections and tests to the *building official* and to the *registered design professional in responsible charge*. Reports shall indicate that work inspected was or was not completed in conformance to *approved construction documents*. Discrepancies shall be brought to the immediate attention of the contractor for correction. If they are not corrected, the discrepancies shall be brought to the attention of the *building official* and to the *registered design professional in responsible charge* prior to the completion of that phase of the work. A final report documenting required *special inspections* and correction of any discrepancies noted in the inspections or tests, shall be submitted to the *building official* prior to the time that phase of the work is approved for occupancy.
(Effective January 1, 2020)

**CHAPTER 18
SOILS AND FOUNDATIONS**

**SECTION 1810
DEEP FOUNDATIONS**

*Revise Section 1810.3.2.6 ‘Allowable stresses’ title to read as follows:

1810.3.2.6 Allowable axial stresses. The allowable stresses for materials used in deep foundation elements shall not exceed those specified in Table 1810.3.2.6.
(Effective January 1, 2020)

*Revise Table 1810.3.2.6 ‘Allowable Stresses for Materials Used in Deep Foundation Elements’ title and item 4 ‘Other conditions’ to read as follows:

**TABLE 1810.3.2.6
ALLOWABLE AXIAL STRESSES FOR MATERIALS USED IN DEEP FOUNDATION ELEMENTS**

MATERIAL TYPE AND CONDITION	MAXIMUM ALLOWABLE <u>AXIAL</u> STRESS ^a
4. Non-prestressed reinforcement in tension	
Within micropiles	$0.6 f_y$
Other conditions	
For load combinations not including wind or seismic loads	$0.5 f_y \leq 24,000$ 30,000 psi
For load combinations including wind or seismic loads	$0.5 f_y \leq 40,000$ psi

Remainder of table and footnotes remain unchanged.
(Effective January 1, 2020)

**CHAPTER 29
PLUMBING SYSTEMS**

**SECTION 2902
MINIMUM PLUMBING FACILITIES**

*Delete the requirements for “service sinks” from Table [P] 2902.1 ‘Minimum Number of Required Plumbing Fixtures^a’ without substitution.
(Effective January 1, 2020)

**CHAPTER 30
ELEVATORS AND CONVEYING SYSTEMS**

**SECTION 3001
GENERAL**

*Revise Table 3001.3 ‘Elevators and Conveying Systems and Components’ under ‘STANDARDS’ for Elevators, escalators, dumbwaiters, moving walks, material lifts to add the following new standards to read as follows:

**TABLE 3001.3
ELEVATORS AND CONVEYING SYSTEMS AND COMPONENTS**

TYPE	STANDARDS
Elevators, escalators, dumbwaiters, moving walks, material lifts	ANSI/ASSE A10.4, ANSI/ASSE A10.5

(Effective January 1, 2020)

**SECTION 3002
HOISTWAY ENCLOSURES**

*Revise Section 3002.4 ‘Elevator car to accommodate ambulance stretcher’ to add a new exception at the end of the section to read as follows:

3002.4 Elevator car to accommodate ambulance stretcher.

Exception: Elevators with 50 feet or less of travel serving only one residence of a one- or two-family dwelling or townhouse shall be in compliance with ASME A17.1 as currently adopted and amended by the Georgia Office of Safety Fire Commissioner.

(Effective January 1, 2020)

**SECTION 3005
MACHINE ROOMS**

*Delete Section 3005.4 ‘Machine rooms, control rooms, machinery spaces and control spaces’ and substitute to read as follows:

3005.4 Machine rooms and machinery spaces. Elevator machine rooms and machinery spaces shall be enclosed with *fire barriers* constructed in accordance with Section 707 or *horizontal assemblies* constructed in accordance with Section 711, or both. The *fire- resistance rating* shall be not less two hours. Openings in the *fire barriers* shall be protected with assemblies having a *fire protection rating* not less than that required for the hoistway enclosure doors.

Exception: Where machine rooms and machinery spaces do not meet the required *fire-resistance rating*, they shall require sprinklers and shunt trip breaker in accordance with NFPA 72.

(Effective January 1, 2020)

*Revise Section 3005.5 ‘Shunt trip’ to read as follows:

3005.5 Shunt trip. Where elevator hoistways or elevator machine rooms containing elevator control equipment are protected with automatic sprinklers, a means installed in accordance with NFPA 72, Section 6.16.4, Elevator Shutdown, shall be provided to disconnect automatically the main line power supply to the affected elevator prior to the application of water. If the means is located in the affected elevator machine room, it shall be in a water resistant enclosure. This means shall not be self-resetting. The activation of sprinklers outside the hoistway or machine room shall not disconnect the main line power supply. Machine rooms having a two-hour fire separation from the building and provided with smoke detection interconnected to the building fire alarm system are not required to be sprinklered.

(Effective January 1, 2020)

CHAPTER 34 EXISTING STRUCTURES

*Revise the title of Chapter 34 ‘Reserved’ to read as ‘Existing Buildings’ and carry forward all the provisions from Chapter 34 ‘Existing Buildings’ of the 2012 *International Building Code*.

(Effective January 1, 2020)

SECTION 3401 GENERAL

*Add new Section 3401.7 ‘Existing system conformance’ to read as follows:

3401.7 Existing system conformance. The extent to which the existing mechanical, electrical, plumbing and life safety systems shall be made to conform to the requirements of the State Minimum Standard Codes for new construction shall be as follows unless otherwise required by this section:

1. When the estimated cost of the new work is less than fifty percent (50%) of the replacement cost of the existing system, the new work shall be brought in to conformance with the requirements of the State Minimum Standard Codes for new construction.
2. When the estimated cost of the new work is equal to or greater than fifty percent (50%) of the replacement cost of the existing system, the entire system shall be made to conform to the requirements of the State Minimum Standard Codes for new construction.
3. For essential service facilities Occupancy Category IV type buildings as defined by Table 1604.5, when the estimated cost of the new work is equal to or greater than thirty percent (30%) of the replacement cost of the existing system, the entire system shall be made to conform to the requirements of the State Minimum Standard Codes for new construction.

(Effective January 1, 2020)

**SECTION 3408
CHANGE OF OCCUPANCY**

*Add new Section 3408.2.1 ‘Assisted living communities’ to read as follows:

3408.2.1 Assisted living communities. Existing buildings or portions of buildings proposed as a change of occupancy to Assisted Living Communities, licensed by the State, housing twenty-five or more persons, shall be allowed to meet the Georgia State Fire Marshal’s Office Life Safety Code requirements for primary equivalent compliance to the *International Building Code* Chapters 3, 4, 8, 9, and 10.

(Effective January 1, 2020)

**CHAPTER 35
REFERENCED STANDARDS**

*Revise Chapter 35 ‘Referenced Standards’ to add the following new reference standards to read as follows:

ACEC/GA		American Council of Engineering Companies of Georgia Peachtree Center, Harris Tower, Suite 700 233 Peachtree Street Atlanta, GA 30303
Standard reference number	Title	Referenced in code section number
ACEC/SEAOG SI GL 01—12	Georgia Special Inspections Guidelines (http://www.seaog.org/si.html)	1704.2.1, GA Amendments
ASTM		ASTM International 100 Barr Harbor Drive West Conshohocken, PA 19428-2859
Standard reference number	Title	Referenced in code section number
E 329—11c	Standard Specification for Agencies Engaged in Construction Inspection, Testing, or Special Inspection	1704.2.1, GA Amendments
ANSI/ASSE		American Society of Safety Engineers 520 N. Northwest Highway Park Ridge, IL 60068
Standard reference number	Title	Referenced in code section number
A10.4-2016	Safety Requirements for Personnel Hoist and Employee Elevators on Construction and Demolition Sites	Table 3001.3, GA Amendments
A10.5-2013	Safety Requirements for Material Hoists	Table 3001.3, GA Amendments

Remainder of reference standards remain unchanged.

(Effective January 1, 2020)

**APPENDIX O
DISASTER RESILIENT CONSTRUCTION**

*The Department of Community Affairs hereby adopts Appendix O ‘Disaster Resilient Construction’ as optional. This document can be downloaded at <https://dca.ga.gov/local-government-assistance/construction-codes-industrialized-buildings/construction-codes>.
(Effective: January 1, 2020)

End of Amendments.

PROPOSED



Georgia State
International Building Code
Appendix O
Disaster Resilient Construction
(2020 Edition)



Georgia Department of Community Affairs
Local Government Assistance Division
60 Executive Park South, N.E.
Atlanta, Georgia 30329-2231
(404) 679-3118
www.dca.ga.gov

January 1, 2020

GEORGIA STATE INTERNATIONAL BUILDING CODE
APPENDIX O
DISASTER RESILIENT CONSTRUCTION

The INTERNATIONAL BUILDING CODE, 2018 Edition, published by the International Code Council, when used in conjunction with the Georgia State Amendments to the INTERNATIONAL BUILDING CODE, 2018 Edition and Appendix O Disaster Resilient Construction, shall constitute the official *Georgia State Minimum Standard Building Code*.

FORWARD

Introduction

The Department of Community Affairs (DCA) was awarded a grant through the U.S. Department of Housing and Urban Development (HUD) to develop Disaster Resilient Building Code (DRBC) Appendices for the International Building Code (IBC) and the International Residential Code (IRC). The DRBC Appendices are optional regulations that local jurisdictions may adopt, in whole or in part, through local ordinance. A task force of stakeholders was appointed to look for opportunities to improve any code provisions relating to damage from hurricane, flood, and tornado disasters. In addition to the approved recommendations from the task force, the state has developed and will conduct a comprehensive training program for code enforcement officials on the importance, implementation and enforcement of the Disaster Resilient Construction Appendices.

The meetings for the Disaster Resilient Building Code Appendices Task Force were open to the public, interested individuals and organizations that desired participation. The technical content of currently published documents on flooding, high-wind construction, and storm shelters, were used and referenced. Those publications included documents of the International Code Council (ICC), American Society of Civil Engineers (ASCE), the Federal Emergency Management Agency (FEMA), Mitigation Assessment Team (MAT) Program, Georgia Emergency Management Agency/Homeland Security (GEMA), APA – The Engineered Wood Association, National Institute of Standards and Technology (NIST), National Oceanic and Atmospheric Administration (NOAA), National Science Foundation (NSF), The State of Florida, American Forest & Paper Association’s American Wood Council, Southern Forest Products Association, NAHB Research Center, Insurance Institute for Business & Home Safety, and the Federal Alliance for Safe Homes.

Adoption

Local jurisdictions may adopt this entire appendix with chosen options or specific sections that apply to their communities through a local ordinance. The adopting ordinance must also be filed on record with DCA. A sample ordinance has been included in this document to assist the local jurisdictions with the adoption process. Recommended training is being offered to assist code enforcement officials in the implementation and enforcement of the appendices documents. Contact DCA at (404) 679-3118 or www.dca.ga.gov for more information.

Neither The Disaster Resilient Building Code Appendices Task Force, its members nor those participating in the development of Appendix O Disaster Resilient Construction accept any liability resulting from compliance or noncompliance with the provisions of Appendix O Disaster Resilient Construction.

The 2012 Disaster Resilient Building Code (DRBC) Appendices Task Force was charged with the development of two appendices. One appendix is for the International Residential Code and the other appendix is for the International Building Code. These two appendices look for opportunities to improve any provisions relating to hurricane, flood, and tornado disasters. In addition to improving existing provisions in the codes, the task force also developed new provisions to be included in the appendices that address these issues. These appendices contain increased construction requirements for disaster resilience and are intended to be made available for adoption by local jurisdictions in the State of Georgia.

These appendices have reasonable and substantial connection with the public health, safety, and general welfare. In addition, the financial impact and costs associated with these appendices have been taken into consideration.

Members:

Mr. Gregori Anderson, Chairman, States Codes Advisory Committee (SCAC)
Mr. David L. Adams, , Vice Chairman, States Codes Advisory Committee (SCAC)
Mr. Bill Abballe, AIA, American Institute of Architects (AIA) – Georgia Chapter
Mr. John Hutton, P.E., S.E., American Council of Engineering Companies of Georgia (ACEC/G)
Mr. Ron Anderson, Code Consultant
Mr. Lamar Smith, Home Builders Association of Georgia (HBAG)
Mr. Thomas Harper, Georgia State Inspectors Association (GSIA)
Mr. Tom Buttram, Building Officials Association of Georgia (BOAG)
Capt. Zane Newman, Georgia State Fire Marshal’s Office (Local Fire Official)
Mr. Terry Lunn, Georgia Emergency Management Agency (GEMA)
Mr. Alan Giles, , CFM, Georgia Department of Natural Resources (EPD / Floodplain Management Unit)
Mr. Tony Hebert, HUD Georgia State Representative (Region IV Office)
Mr. Jim C. Beck, Sr., Georgia Underwriting Association
Mr. Tim Thornton, Georgia Association of Realtors (GAR)
Mr. Steve Harrison, Building Owners and Managers Association – Georgia (BOMA)
Mr. Tom Aderhold, Georgia Apartment Association (GAA)
Mr. Tim Bromley, Accessibility Consultant – Georgia State ADA Coordinator’s Office
Mayor Mark Mathews, Georgia Municipal Association (GMA)
Commissioner Jeff Long, Association of County Commissioners of Georgia (ACCG)

Ad Hoc Subcommittee:

Mr. Tom Buttram, Chairman, DRBC Task Force Liaison (BOAG)
Mr. Ron Anderson, Vice Chairman, Code Consultant
Mr. Stephen V. Skalko, Concrete Industry
Mr. Jeffrey B. Stone, Wood Industry (AWC)
Mr. Robert Wills, Steel Industry (AISC)
Mr. Tom Cunningham, PhD., Residential Building Design
Mr. Duncan J. Hastie, P.E., Disaster Mitigation

DCA Staff:

Mr. Ted Miltiades, Director of Construction Codes & Industrialized Buildings
Mrs. Deirdre “Dee” Leclair, DRBC Grant Project Manager
Mr. Max Rietschier, Lead Codes Consultant
Mr. Bill Towson, 2012 International Residential Code Task Force Liaison, Code Consultant
Mr. Calvin Jordan, 2012 International Building Code Task Force Liaison, Code Consultant

How to Use Appendix O Disaster Resilient Construction

The appendix may be adopted in whole or in part by Local Jurisdictions to fit the needs of their community. The following sample ordinance has been provided to aid in the process of identifying Chapters and Sections of the appendix that may be adopted. The format easily allows for choosing to adopt, revise or delete individual Chapters and Sections. Download the MS Word (.doc) version from the DCA website to take advantage of the dropdown menu choices and edit ability features of the document. Note that in Chapter 3, choose one of three options for flood elevation. Only one option may be chosen and that option must be higher than what has been previously adopted and enforced by the jurisdiction. Also note that in Chapter 4, choose one of three options for increased wind load. Only one option may be chosen and that option must be higher than what has been previously adopted and enforced by the jurisdiction. The Sample Ordinance document takes into account the flood elevation option in Chapter 3 and the wind load option in Chapter 4 of this appendix.

**SAMPLE ORDINANCE FOR ADOPTION OF
GEORGIA STATE INTERNATIONAL BUILDING CODE**

**APPENDIX O
DISASTER RESILIENT CONSTRUCTION**

ORDINANCE NO. _____

An ordinance of the [JURISDICTION] adopting the latest edition as adopted and amended by the Georgia Department of Community Affairs of *Appendix O Disaster Resilient Construction* regulating and governing the mitigation of hazard to life and property from natural weather related disasters, high-wind damages, flooding, and establishing construction standards for storm shelters in the [JURISDICTION]; providing for the issuance of permits and collection of fees therefore; repealing Ordinance No. ____ of the [JURISDICTION] and all other ordinances or parts of the laws in conflict therewith.

The [GOVERNING BODY] of the [JURISDICTION] does ordain as follows:

Section 1. That a certain document, three (3) copies of which are on file in the office of the [TITLE OF JURISDICTION'S KEEPER OF RECORDS] of [NAME OF JURISDICTION], being marked and designated as *Appendix O Disaster Resilient Construction* to the International Building Code, the latest edition as adopted and amended by the Georgia Department of Community Affairs, be and is adopted as the *Appendix O Disaster Resilient Construction* of the [JURISDICTION], in the State of Georgia for regulating and governing the mitigation of hazard to life and property from natural weather related disasters, high-wind damages, flooding, and establishing construction standards for storm shelters; providing for the issuance of permits and collection of fees therefore; and each and all of the regulations, provisions, penalties, conditions and terms of said *Appendix O Disaster Resilient Construction* on file in the office of the [JURISDICTION] are hereby referred to, adopted, and made a part hereof, as if fully set out in this ordinance, with the additions, insertions, deletions and changes, if any prescribed in Section 2 of this ordinance.

Section 2. [NAME OF JURISDICTION] hereby:

Choose an item. CHAPTER AO1 SCOPE AND ADMINISTRATION Choose an item.

Choose an item. SECTION AO101 ADMINISTRATION Choose an item.

Choose an item. AO101.1 Purpose Choose an item.

Choose an item. AO101.2 Objectives Choose an item.

Choose an item. AO101.3 Scope Choose an item.

AO101.3.1 Insert [Name Of Jurisdiction] for [NAME OF JURISDICTION].

Choose an item. AO101.4 Violations Choose an item.

Insert [Name Of Jurisdiction] for [NAME OF JURISDICTION].

Choose an item. SECTION AO102 APPLICABILITY Choose an item.

Choose an item. AO102.1 General Choose an item.

Choose an item. AO102.2 Other laws Choose an item.

Choose an item. AO102.3 Referenced codes and standards Choose an item.

Choose an item. SECTION AO103 POST DISASTER EVENT INSPECTIONS GUIDELINES Choose an item.

Choose an item. AO103.1 Inspections Choose an item.

Choose an item. AO103.1.1 Right of entry Choose an item.

Choose an item. AO103.2 Types of inspections Choose an item.

Choose an item. AO103.3 Post disaster building safety evaluation chart Choose an item.

Choose an item. Figure AO103.3 Post Disaster Building Safety Evaluation Chart Choose an item.

Choose an item. AO103.4 Evaluation Forms Choose an item.

Insert [Name Of Jurisdiction] for [NAME OF JURISDICTION].

Choose an item. AO103.5 Placement and remove of placards Choose an item.

Choose an item. CHAPTER AO2 DEFINITIONS Choose an item.

Choose an item. SECTION AO201 GENERAL Choose an item.

Choose an item. AO201.1 Scope Choose an item.

Choose an item. AO201.2 Terms defined in other codes Choose an item.

Choose an item. AO201.3 Terms not defined Choose an item.

Choose an item. SECTION AO202 DEFINITIONS Choose an item.

Choose an item. CHAPTER AO3 FLOOD-RESISTANT CONSTRUCTION Choose an item.

Choose an item. SECTION AO301 HAZARD IDENTIFICATION Choose an item.

Choose an item. AO301.1 Identification of flood hazard areas Choose an item.

Insert [Name Of Jurisdiction] for [NAME OF JURISDICTION].

Insert [Date of Issuance] for [DATE OF ISSUANCE].

Choose an item. SECTION AO302 SCOPE Choose an item.

Choose an item. AO301.1 Flood Loads Choose an item.

Choose an item. FLOOD ELEVATION OPTION Choose an item. Choose an item.

Choose an item. SECTION AO303 FLOOD DAMAGE-RESISTANT MATERIALS Choose an item.

Choose an item. AO303.1 Flood damage-resistant materials Choose an item.

Choose an item. AO303.2 Location of flood damage-resistant materials Choose an item.

Choose an item. AO303.3 Fasteners and connectors used for flood-resistant materials Choose an item.

Choose an item. CHAPTER AO4 HIGH-WIND RESISTIVE CONSTRUCTION Choose an item.

Choose an item. SECTION AO401 GENERAL Choose an item.

Choose an item. AO401.1 Applications Choose an item.

Choose an item. AO401.2 Limitations Choose an item.

Choose an item. AO402 DEFINITIONS AND NOTATIONS Choose an item.

Choose an item. AO403 WIND LOADS Choose an item.

Choose an item. AO403.1 Wind Directionality Factor Choose an item.

Choose an item. AO403.2 Exposure Choose an item.

Choose an item. AO403.3 Enclosure classification Choose an item.

Choose an item. AO403.4 Continuous operation of Risk Category IV buildings Choose an item.

Choose an item. SECTION Choose an item. Choose an item.

Choose an item. CHAPTER AO5 STORM SHELTERS, SAFE ROOMS AND BEST AVAILABLE REFUGE AREAS Choose an item.

Choose an item. SECTION AO501 GENERAL Choose an item.

Choose an item. AO501.1 General Choose an item.

Choose an item. AO501.2 Occupant load Choose an item.

Choose an item. AO501.3 Construction documents Choose an item.

Choose an item. AO501.4 Signage Choose an item.

Choose an item. SECTION AO502 DEFINITIONS AND NOTATIONS Choose an item.

Choose an item. AO502.1 Definitions Choose an item.

Choose an item. AO502.2 Additional definitions Choose an item.

Choose an item. SECTION AO503 BEST AVAILABLE REFUGE AREAS Choose an item.

Choose an item. AO503.1 General Choose an item.

Choose an item. AO503.2 Occupant Density Choose an item.

Choose an item. AO503.3 Identification of best available refuge areas Choose an item.

Choose an item. SECTION AO504 APPLICABILITY Choose an item.

Choose an item. AO504.1 Required storm shelters or safe rooms Choose an item.

Section 3. That Ordinance No. ____ of [JURISDICTION] entitled [FILL IN HERE THE COMPLETE TITLE OF THE LEGISLATION OR LAWS IN EFFECT AT THE PRESENT TIME SO THAT THEY WILL BE REPEALED BY DEFINITE MENTION] and all other ordinances or parts of laws in conflict herewith are hereby repealed.

Section 4. That if any section, subsection, sentence, clause or phrase of this ordinance is, for any reason, held to be unconstitutional, such decision shall not affect the validity of the remaining portions of this ordinance. The [GOVERNING BODY] hereby declares that it would have passed this law, and each section, subsection, clause or phrase thereof, irrespective of the fact that any one or more sections, subsections, sentences, clauses and phrases be declared unconstitutional.

Section 5. That nothing in this ordinance or in *Appendix O Disaster Resilient Construction* hereby adopted shall be construed to affect any suit or proceeding impending in any court, or any rights acquired, or liability incurred, or any cause or causes of action acquired or existing under any act or ordinance hereby repealed as cited in Section 3 of this ordinance; nor shall any just or legal right or remedy of any character be lost, impaired or affected by this ordinance.

Section 6. That the [JURISDICTION'S KEEPER OF RECORDS] is hereby ordered and directed to cause this ordinance to be published. (An additional provision may be required to direct the number of times the ordinance is to be published and to specify that it is to be in a newspaper in general circulation. Posting may also be required.)

Section 7. That this ordinance and the rules, regulations, provisions, requirements, orders and matters established and adopted hereby shall take effect and be in full force and effect [TIME PERIOD] from and after the date of its final passage and adoption.

Section 8. Chapter AO6 Resources, of this document is intended to be used by the building officials as a resource guide.

PROPOSED

TABLE OF CONTENTS

CHAPTER AO1 Scope and Administration	8	CHAPTER AO6 Resources	16
Section		Section	
AO101 Administration	8	AO601 Contacts	16
AO102 Applicability	8	AO602 Emergency Inspection Kit	16
AO103 Post Disaster Event Inspections Guidelines	9	AO603 Safety Tips	17
CHAPTER AO2 Definitions	11	AO604 Major Disaster Process	17
Section		AO605 Sample Evaluation Forms and Placards.	17
AO201 General	11	CHAPTER AO7 References	24
AO202 Definitions	11	INDEX OF FIGURES.	24
CHAPTER AO3 Flood-resistant Construction	12		
Section			
AO301 Hazard Identification	12		
AO302 Scope	12		
AO303 Flood damage-resistant materials	12		
CHAPTER AO4 High-wind Resistive Construction	13		
Section			
AO401 General	13		
AO402 Definitions and Notations	13		
AO403 Wind Loads	13		
AO404 Wind Load Option A	13		
AO405 Wind Load Option B	14		
AO406 Wind Load Option C	14		
CHAPTER AO5 Storm Shelters, Safe Rooms and Best Available Refuge Areas.	15		
Section			
AO501 General	15		
AO502 Definitions and Notations	15		
AO503 Best Available Refuge Areas	15		
AO504 Applicability	15		

APPENDIX O DISASTER RESILIENT CONSTRUCTION

CHAPTER AO1 SCOPE AND ADMINISTRATION

SECTION AO101 ADMINISTRATION

AO101.1 Purpose. The scope of this appendix is to promote enhanced public health, safety and general welfare and to reduce public and private property losses due to hazards and natural disasters associated with flooding, high-winds, and windborne debris above that which is provided in the general provisions of this appendix.

AO101.2 Objectives. The objectives of this appendix are to:

1. Protect human life, to minimize property loss and to minimize the expenditures of public money associated with natural weather related disasters, including flooding, tornadoes and other high-wind events.
2. Establish enhanced design and construction regulations consistent with nationally recognized good practices for the safeguarding of life and property.

AO101.3 Scope.

AO101.3.1 The provisions of this appendix are not mandatory unless specifically referenced in an adopting ordinance of [NAME OF JURISDICTION]. If adopted, the provisions shall apply to all new development and to substantial improvements to existing development.

AO101.3.2 The provisions of this appendix supplement the jurisdiction's building and fire codes to provide for enhanced provisions to mitigate the hazard to life and property from natural weather related disasters, including flooding, tornadoes and other high-wind events.

AO101.3.3 The provisions of this appendix establish design and construction standards for storm shelters.

AO101.4 Violations. Any violation of a provision of this appendix or failure to comply with a permit of variance issued pursuant to this appendix or any requirement of this appendix shall be handled in accordance with the ordinances of [NAME OF JURISDICTION].

SECTION AO102 APPLICABILITY

AO102.1 General. This appendix provides enhanced minimum requirements for development of new construction and substantial improvement of existing development above that contained in the *International Building Code (IBC)*.

AO102.1.1 The provisions of this appendix shall apply to all new construction and additions, and shall apply to substantial alterations in flood hazard areas unless it is technically infeasible or otherwise exempted in Section 3403.2 of the *International Building Code*.

AO102.1.2 Regardless of the category of work being performed, the work shall not cause the structure to become unsafe or adversely affect the performance of the building; shall not cause an existing mechanical or plumbing system to become unsafe, hazardous, insanitary or overloaded; and unless expressly permitted by these provisions, shall not make the building any less compliant with this appendix or to any previously approved alternative arrangements than it was before the work was undertaken.

AO102.1.3 Where there is a conflict between a requirement of the *International Building Code* and a requirement of this appendix, the requirement of this appendix shall govern. Where there is a conflict between a general requirement of this appendix and a specific requirement of this appendix, the specific requirement shall govern. Where, in any specific case, different sections of this appendix specify different materials, methods of construction or other requirements, the most restrictive shall govern.

AO102.2 Other laws. The provisions of this appendix shall not be deemed to nullify any provisions of local, state or federal law.

AO102.3 Referenced codes and standards. The codes and standards referenced in this appendix shall be those that are listed in Chapter AO7 and such codes and standards shall be considered as part of the requirements of this appendix to the prescribed extent of each such reference. Where differences occur between provisions

this appendix and referenced codes and standards, the provisions of this appendix shall apply.

SECTION AO103 POST DISASTER EVENT INSPECTIONS GUIDELINES

AO103.1 Inspections. The building official or agents shall inspect buildings and structures to determine the habitability of each with the goal of getting the community back into their residences quickly and safely. Inspections shall always be performed by teams of at least two individuals, also known as disaster assessment teams.

AO103.1.1 Right of entry. Unless permitted under the exigent circumstances provisions or from an order from State or Federal Authorities, disaster assessment teams shall confirm the right of entry requirements with the incident commander. Upon approval, the assessment teams shall be authorized to enter the structure or premises at reasonable times to inspect or perform duties as provided by this code, provided that the structure or premises be occupied, that credentials are presented, that entry is requested, and that entry is granted by the owner or person having charge over the structure or premises.

AO103.2 Types of inspections.

AO103.2.1 Rapid evaluation. Rapid evaluation is performed after a disaster event to determine if a building is apparently safe or obviously unsafe. The evaluation should last 10 to 30 minutes per building and shall be performed by the building official and/or their designated responders. Evaluation shall determine if a detailed evaluation is necessary. Placards are posted on buildings indicating status as one of the following:

1. INSPECTED
2. RESTRICTED USE
3. UNSAFE

See Section AO605 for Placards that may be reproduced for use in the field during evaluations. The jurisdiction shall alter placards to meet the jurisdiction and building department's requirements.

AO103.2.2 Detailed evaluation. Detailed evaluation is a thorough visual examination of a damaged building performed by a team of two, including an inspector and a design professional. Evaluation should last 30 minutes to 4 hours per building. Evaluation shall determine necessary restrictions on a damaged building's use, the need for an engineering evaluation or to evaluate postings.

AO103.2.3 Engineering evaluation. When indicated by the building official as necessary, engineering evaluations shall be completed by a registered design professional hired by the building owner.

AO103.3 Post disaster building safety evaluation chart. See Figure AO103.3 for Post Disaster Building Safety Evaluation Chart.

AO103.4 Evaluation Forms. *ATC-45 Rapid Evaluation Safety Assessment Form* and *ATC-45 Detailed Evaluation Safety Assessment Form* shall be used by [Name of Jurisdiction]'s Building Official for post disaster inspections. See Section AO605 for copies of the Safety Assessment Forms.

AO103.5 Placement and removal of placards.

AO103.5.1 Placement. Placards are to be posted in a clearly visible location near the main entrance and shall be visible from the public right-of-way. RESTRICTED USE or UNSAFE placards shall be placed at all entrances.

AO103.5.2 Removal. Placards shall not be removed or replaced, except by the authorized representatives of the local jurisdiction.

Figure AO103.3 Post Disaster Building Safety Evaluation Chart ^a

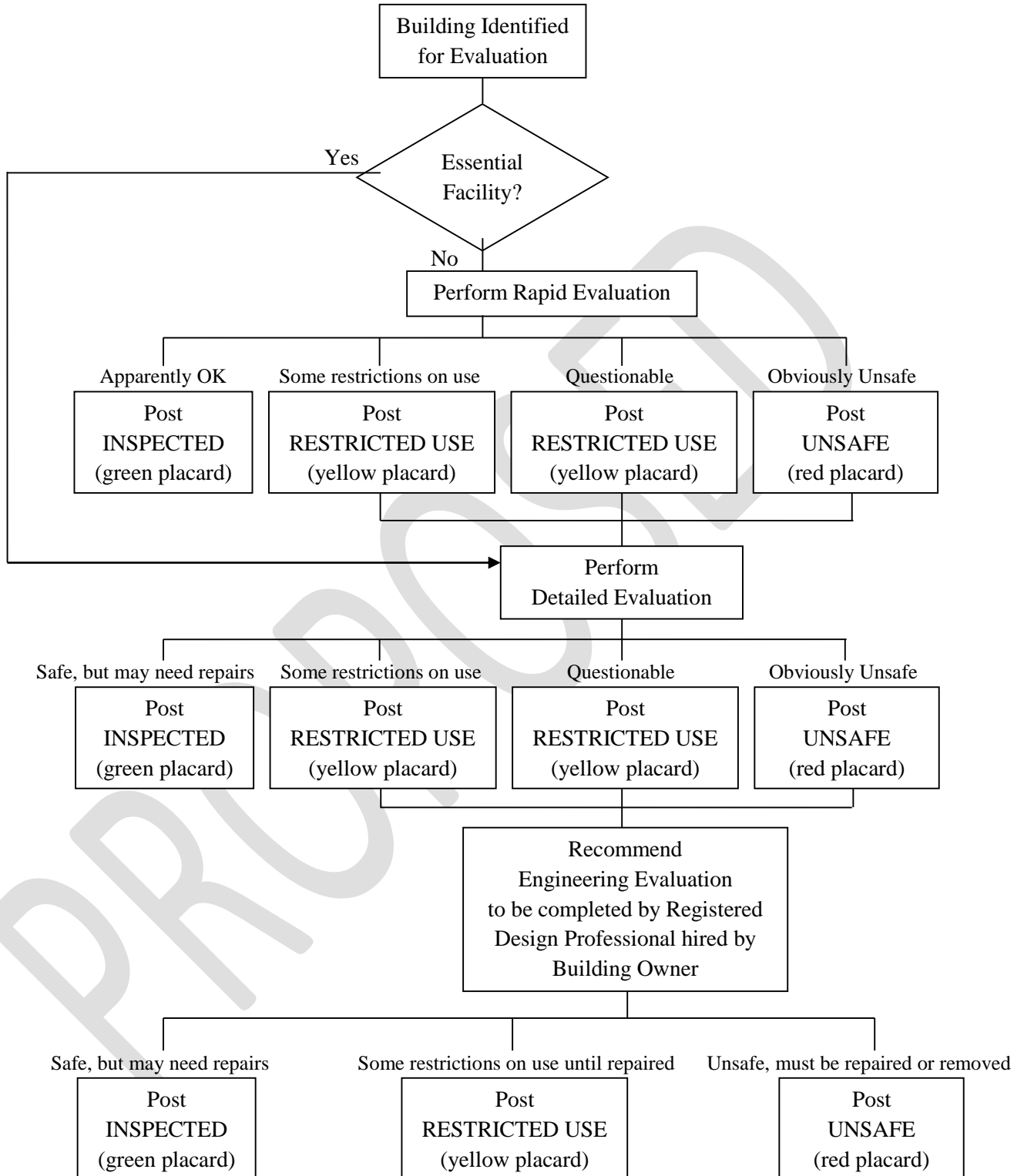

^(a)*When Disaster Strikes* by the International Code Council, Inc., Seventh Printing: November 2011, copyright 2007

CHAPTER AO2 DEFINITIONS

SECTION AO201 GENERAL

AO201.1 Scope. Unless otherwise expressly stated the following words and terms shall, for the purposes of this appendix, have the meanings shown in this chapter.

AO201.2 Terms defined in other codes. Where terms are not defined in this appendix and are defined in other *International Codes*, such terms shall have the meanings ascribed to them as in those codes.

AO201.3 Terms not defined. Where terms are not defined through the methods authorized by this section, such terms shall have their ordinarily accepted meanings such as the context implies.

SECTION AO202 DEFINITIONS

500-YEAR FLOOD. Flood having a 0.2% annual probability of being equaled or exceeded.

ADVISORY BASE FLOOD ELEVATION (ABFE). An advisory base flood elevation (BFE) issued by the Federal Emergency Management Agency (FEMA) that reflects post-storm conditions and vulnerability to damages from future flooding.

BASE FLOOD. Flood having a 1% chance of being equaled or exceeded in any given year, also referred to as the 100-year flood.

BASE FLOOD ELEVATION (BFE). The elevation of flooding, including wave height, having a 1% chance of being equaled or exceeded in any given year established relative to the National Geodetic Vertical Datum (NGVD), North American Vertical Datum (NAVD) or other datum specified on the *Flood Insurance Rate Map (FIRM)*.

BUILDING OFFICIAL. The officer or other designated authority charged with the administration and enforcement of the *International Building Code*, or the building official's duly authorized representative.

DESIGN FLOOD. The greater of the following two flood events:

- (1) The *base flood*, affecting those areas identified as *special flood hazard areas* on the community's FIRM;
- (2) The flood corresponding to the area designated as a *flood hazard area* on a community's *flood hazard map* or otherwise legally designated.

DESIGN FLOOD ELEVATION (DFE). The elevation of the *design flood*, including wave height, relative to the datum specified on the community's legally designated flood hazard map. In areas designated as Zone AO, the *design flood elevation* shall be the elevation of the highest existing grade of the building's perimeter plus the depth number (in feet) specified on the flood hazard map.

FLOOD [DAMAGE]-RESISTANT MATERIAL. Any building product [material, component or system] capable of withstanding direct and prolonged contact with floodwaters without sustaining significant damage.

FLOOD HAZARD MAP. Map delineating *flood hazard areas* adopted by the authority having jurisdiction.

FLOOD INSURANCE RATE MAP (FIRM). An official map of a community on which the Federal Emergency Management Agency (FEMA) has delineated both the *special flood hazard areas* and the risk premium zones applicable to the community.

FREEBOARD. A factor of safety expressed in feet above a flood level for purposes of floodplain management.

FUTURE-CONDITIONS FLOOD. The flood having a 1% chance of being equaled or exceeded in any given year based on future-conditions hydrology. Also known as the 100-year future-conditions flood.

FUTURE-CONDITIONS FLOOD ELEVATION. The flood standard equal to or higher than the Base Flood Elevation. The future-conditions flood elevation is defined as the highest water surface anticipated at any given point during the future-conditions flood.

CHAPTER AO3 FLOOD-RESISTANT CONSTRUCTION

Forward: This appendix provides three different options for increased freeboard. The jurisdiction may pick only one option that is higher than previously adopted and enforced by the jurisdiction. The National Flood Insurance Program (NFIP) minimum standards reference Base Flood Elevation without any freeboard in high risk flood hazard areas. Due to the flood damage prevention updates performed during the Map Modernization initiative that led to flood risks being digitally identified in all 159 Georgia counties, all Georgia NFIP participating communities have freeboard standards that meet or exceed the 1 foot standard used in the State model ordinances for areas where BFEs have been established.

SECTION AO301 HAZARD IDENTIFICATION

AO301.1 Identification of flood hazard areas. To establish flood hazard areas:

- (a) flood hazard map adopted by jurisdiction based on areas of special flood hazard as identified by the Federal Emergency Management Agency in an engineering report entitled “The Flood Insurance Study of [INSERT NAME OF JURISDICTION],” dated [INSERT DATE ISSUANCE], and amended or revised with the accompanying Flood Insurance Rate Map (FIRM) and Flood Boundary and Floodway Map (FBFM) and related supporting data along with any revisions thereto.
- (b) FIRM maps provided by the Federal Emergency Management Agency.

SECTION AO302 SCOPE

AO302.1 Flood loads. Buildings designed and constructed in flood hazard areas defined in IBC Section 1612.3 shall comply with the following:

AO302.1.1 Flood hazard areas without base flood elevations. In flood hazard areas without base flood or future-conditions flood elevation data, new construction and substantial improvements of existing structures shall have the lowest floor of the lowest enclosed area (including basement) elevated no less than three (3) feet above the highest adjacent grade to the building foundation.

OPTION A – FLOOD ELEVATION

AO302.1.2 Increase to base flood elevation requirements. Floors required by ASCE 24 to be built above base flood elevations as follows:

The higher of:

- (a) Design flood elevation plus one (1) foot, or
- (b) Base flood elevation plus one (1) foot, or
- (c) Advisory base flood elevation, or
- (d) Future-conditions plus one (1) foot, if known or

- (e) 500-year flood, if known

OPTION B– FLOOD ELEVATION

AO302.1.3 Increase to base flood elevation requirements. Floors required by ASCE 24 to be built above base flood elevations as follows:

The higher of:

- (a) Design flood elevation plus two (2) feet, or
- (b) Base flood elevation plus two (2) feet, or
- (c) Advisory base flood elevation, or
- (d) Future-conditions plus one (1) foot, if known or
- (e) 500-year flood, if known

OPTION C – FLOOD ELEVATION

AO302.1.4 Increase to base flood elevation requirements. Floors required by ASCE 24 to be built above base flood elevations as follows:

The higher of:

- (a) Design flood elevation plus three (3) feet, or
- (b) Base flood elevation plus three (3) feet, or
- (c) Advisory base flood elevation, or
- (d) Future-conditions plus one (1) foot, if known or
- (e) 500-year flood, if known

SECTION AO303 FLOOD DAMAGE-RESISTANT MATERIALS

AO303.1 Flood damage-resistant materials. Flood damage-resistant materials comply with FEMA Technical Bulletin 2, Table 2. Types, Uses, and Classifications of Materials.

AO303.2 Location of flood damage-resistant materials. Building components and materials located below the increase to base flood elevation as determined by the local jurisdiction in accordance with AO302.1 shall be flood damage-resistant as defined by Section AO303.1.

AO303.3 Fasteners and connectors used for flood damage-resistant materials. Fasteners and connectors used for flood damage-resistant materials to be made of stainless steel, hot-dipped zinc-coated galvanized steel, mechanically deposited-zinc coated, silicon bronze or copper. Copper fasteners shall not be permitted for use in conjunction with steel.

CHAPTER AO4 HIGH-WIND RESISTIVE CONSTRUCTION

SECTION AO401 GENERAL

AO401.1 Applications. Buildings, and parts thereof shall be designed to withstand the minimum wind loads and meet the opening protection requirements of IBC Section 1609 as modified in this chapter. **Wind Load Option A, B or C shall be selected. Table AO401.1 may be used to assist in the selection of an appropriate Wind Load Option.**

AO401.2 Limitations. The following limitations shall apply to the design and construction of buildings with respect to winds.

AO401.2.1 Empirical masonry. The empirical masonry provisions in IBC Section 2109 or Chapter 5 of TMS 402/ACI 530/ASCE 5 shall not be permitted to be used for the wind load resisting elements of buildings, or parts of buildings or other structures.

AO401.2.2 Unreinforced (plain) masonry. The unreinforced masonry provisions in IBC Section 2109 or sections 2.2, 3.2 or 8.2 of TMS 402/ACI 530/ASCE 5 shall not be permitted to be used for the wind load resisting elements of buildings, or parts of buildings or other structures.

AO401.2.3 Conventional light-frame construction. The *conventional light-frame construction* provisions in IBC Section 2308 shall not be permitted to be used for the wind load resisting elements of buildings, or parts of buildings or other structures.

Exception: Compliance with AF&PA WFCM shall be permitted subject to the limitations therein and the limitations of this appendix.

SECTION AO402 DEFINITIONS AND NOTATIONS

AO402.1 General. The following terms are defined in Chapter 2 of the International Building Code:

**CONVENTIONAL LIGHT-FRAME
CONSTRUCTION.**

MASONRY.

Unreinforced (plain) masonry.

WIND-BORNE DEBRIS REGION.

WIND SPEED, V_{ult} .

SECTION AO403 WIND LOADS

AO403.1 Wind Directionality Factor. The directionality factor for Wind Option B and C shall be taken as 1.0.

AO403.2 Exposure. Wind pressures for Wind Option B and C shall be based on exposure category C or D in accordance with IBC Section 1609.4 or ASCE 7.

AO403.3 Enclosure classification. The enclosure classification shall be determined in accordance with ASCE 7 with the largest door or window on a wall that receives positive external pressure considered as an opening.

AO403.4 Continuous operation of Risk Category IV buildings. When a building or an internal area within a building in Risk Category IV is required to remain operational during a design wind event (target performance level OB), that building or that internal area shall be designed in accordance with ICC-500 or FEMA-361.

SECTION AO404 WIND LOAD OPTION A

AO404.1 Basic wind speed. The ultimate design wind speed, V_{ult} , for use in the design of buildings and structures shall be obtained from IBC Section 1609.3.

AO404.2 Debris Hazard and Protection of Openings. Buildings shall be designed for impact resistance in accordance with IBC Section 1609.2 or ASCE 7.

Exception:

1. For Risk Category III buildings with a Life Safety target performance level for the entire building, the exterior glazing shall be impact resistant or be protected with an impact resistant covering meeting the requirements of ASTM E1996.
2. For Risk Category IV buildings with an Immediate Occupancy target performance level for the entire building, the exterior glazing shall be impact resistant or be protected with an impact resistant covering meeting the requirements of ASTM E1996 for *Enhanced Protection*.

**SECTION AO405
WIND LOAD OPTION B**

AO405.1 Basic wind speed. The ultimate design wind speed, V_{ult} , for use in the design of Risk Category I buildings and structures shall be obtained from 0 Section 1609.3. The ultimate design wind speed, V_{ult} , for use in the design of Risk Category II buildings and structures shall be obtained from IBC Figure 1609.3(1). The ultimate design wind speed, V_{ult} , for use in the design of Risk Category III and IV buildings and structures shall be obtained from IBC Figure 1609.3(1) or 135 mph, whichever is greater.

AO405.2 Debris Hazard and Protection of Openings. Buildings shall be designed for impact resistance in accordance with this Section in addition to IBC Section 1609.2 or ASCE 7.

Exception:

- For Risk Category IV buildings, all components of the exterior envelope shall be impact resistant or be protected with an impact resistant covering meeting the requirements of ASTM E1996 for *Enhanced Protection*.

**SECTION AO406
WIND LOAD OPTION C**

AO406.1 Basic wind speed. The ultimate design wind speed, V_{ult} , for use in the design of Risk Category I buildings and structures shall be obtained from IBC Section 1609.3. The ultimate design wind speed, V_{ult} , for use in the design of Risk Category II buildings and structures shall be obtained from IBC Figure 1609.3(1). The ultimate design wind speed, V_{ult} , for use in the design of Risk Category III and IV buildings and structures shall be obtained from IBC Figure 1609.3(1) or 170 mph, whichever is greater.

AO406.2 Debris Hazard and Protection of Openings. Buildings shall be designed for impact resistance in accordance with this Section in addition to IBC Section 1609.2 or ASCE 7.

Exception:

- For Risk Category IV buildings, all components of the exterior envelope shall be impact resistant or be protected with an impact resistant covering meeting the requirements of ASTM E1996 for *Enhanced Protection*.

**Table AO401.1
WIND LOAD OPTIONS:**

TARGET PERFORMANCE LEVELS AND DESIGN CRITERIA⁴

OPTION	DESIGN WIND EVENT	Risk Category II ¹			Risk Category III ¹			Risk Category IV ¹		
		Target Performance Level ²	Min Wind Speed V_{ult}	Wind-Borne Debris	Target Performance Level ²	Min Wind Speed V_{ult}	Wind-Borne Debris	Target Performance Level ²	Min Wind Speed V_{ult}	Wind-Borne Debris
A	EF0 & 1 Tornado – IBC level Hurricane	CP ³	IBC 1609.3	IBC 1609.2 or ASCE 7	CP ³	IBC 1609.3	IBC 1609.2 or ASCE 7	CP ³	IBC 1609.3	IBC 1609.2 or ASCE 7
					LS		Glazing	IO ⁵		Glazing
B	EF2 Tornado – Cat 3 Hurricane	CP ³ for EF0-EF1-IBC Hurricane for Risk Cat. III/IV	IBC 1609.3 for Risk Cat. III/IV	IBC 1609.2 or ASCE 7	LS	145 mph	Req'd for glazing per IBC 1609.2 and ASCE 7	IO ⁵	145 mph	Exterior Envelope
C	EF3 Tornado – Cat 4 Hurricane	CP ³ for EF0-EF1-IBC Hurricane for Risk Cat. III/IV	IBC 1609.3 for Risk Cat. III/IV	IBC 1609.2 or ASCE 7	LS	170 mph	Req'd for glazing per IBC 1609.2 and ASCE 7	IO ⁵	170 mph	Exterior Envelope

Notes:

- Risk Category per IBC Section 1604.5
- Performance Levels:
 CP: Collapse Prevention
 LS: Life Safety
 IO: Immediate Occupancy
 OB: Operational Building
- LS for occupants away from exterior envelope. IO for storm shelters or safe rooms.
- See Section AO401 and Section AO403 for additional limitations and criteria.
- OB for building or an internal area within a building designed to ICC-500 or FEMA 361.

CHAPTER AO5

STORM SHELTERS, SAFE ROOMS AND BEST AVAILABLE REFUGE AREAS

SECTION AO501 GENERAL

AO501.1 General. This section applies to the location and construction of storm shelters and safe rooms when constructed as separate detached buildings or as internal areas within buildings for the purpose of providing safe refuge for storms that produce high winds, such as tornados and hurricanes, and to the selection of best available refuge areas. Storm shelters shall be designed and constructed in accordance with IBC Section 423. Safe rooms shall be designed and constructed in accordance with FEMA 361. Storm shelters, safe rooms, and best available refuge areas shall be located on an accessible route.

Exception: *Residential Safe Rooms* and safe rooms serving a Business Group B Occupancy and having an *occupant load* not exceeding 16 persons may be constructed in accordance with FEMA 320.

AO501.2 Occupant load. The occupant load for storm shelters and safe rooms shall be determined by ICC 500 and FEMA 361 respectively.

AO501.3 Construction documents. Construction documents for buildings containing a storm shelter or safe room shall include the information required in ICC 500 or FEMA 361 respectively. Construction documents for buildings with access to a remote community storm shelter or safe room shall indicate the location of and access to the community storm shelter or safe room. Construction documents for buildings not containing or without access to a remote storm shelter or safe room, shall indicate the best available refuge area.

AO501.4 Signage. The location(s) of storm shelters, safe rooms or the best available refuge area(s) shall be clearly marked with a permanent sign.

SECTION AO502 DEFINITIONS AND NOTATIONS

AO502.1 Definitions. The following terms are defined in Chapter 2 of the International Building Code:

DWELLING UNITS.

OCCUPANT LOAD.

STORM SHELTER.

Community Storm Shelter.

Residential Storm Shelter.

AO502.2 Additional definitions.

BEST AVAILABLE REFUGE AREAS. Areas in a building that have been deemed by a registered design professional to likely offer the greatest safety for building occupants during a tornado or hurricane. Because these areas were not specifically designed as storm shelters or safe rooms, their occupants may be injured or killed during a tornado or hurricane. However, people in the best available refuge areas are less likely to be injured or killed than people in other areas of a building.

SAFE ROOM. A building, structure or portions thereof, constructed in accordance with FEMA 361 and designed for use during a severe wind storm event, such as a hurricane or tornado.

Community Safe Room. A safe room not defined as a “Residential Safe Room”

Residential Safe Room. A safe room serving occupants of *dwelling units* and having an *occupant load* not exceeding 16 persons.

SECTION AO503 BEST AVAILABLE REFUGE AREAS

AO503.1 General. Best available refuge area occupants may be injured or killed during a tornado or hurricane. However, people in the best available refuge areas are less likely to be injured or killed than people in other areas of a building.

AO503.2 Occupant Density. The minimum required floor area per occupant for best available refuge area(s) shall be determined in accordance with ICC 500 Table 501.1.1.

AO503.3 Identification of best available refuge areas. Best available refuge areas shall be identified by a registered design professional in accordance with the Wind Hazard Checklist of FEMA 361, Appendix B and FEMA P-431.

SECTION AO504 APPLICABILITY

AO504.1 Required storm shelters or safe rooms.

1. All new kindergarten through 12th grade schools with 50 or more occupants in total, per school, shall have a storm shelter or safe room.
2. All new 911 call stations, emergency operation centers, and fire, rescue, ambulance, and police stations shall have a storm shelter or safe room.

CHAPTER AO6 RESOURCES

SECTION AO601 CONTACTS

Georgia Department of Community Affairs (DCA) Construction Codes

Georgia State Amendments to the State Minimum
Standard Codes

dca.ga.gov/local-government-assistance/construction-codes-industrialized-buildings/construction-codes

Phone: 404-679-3118

Georgia Department of Natural Resources (DNR) Floodplain Management

4220 International Parkway, Ste. 101

Atlanta, GA 30354-3902

www.georgiadfirm.com

Phone: 404-675-1757

Federal Emergency Management Agency (FEMA)

www.fema.gov; www.floodsmart.gov

www.fema.gov/rebuild/buildingscience/

FEMA Publications and Technical Bulletins:

(www.fema.gov/library/index.jsp)

(www.fema.gov/plan/prevent/floodplain/techbul.shtm)

Georgia Emergency Management Agency (GEMA)

Georgia Office of Homeland Security

P.O. Box 18055

Atlanta, GA 30316-0055

www.gema.ga.gov

www.ready.ga.gov

Phone: 404-635-7000

Georgia Association of Regional Commissions (GARC)

www.garc.ga.gov

(<http://garc.ga.gov/main.php?Regional-Commissions-2>)

(for assistance in identifying Flood Hazard Areas)

International Code Council (ICC)

www.iccsafe.org

National Weather Service

www.weather.gov

State Fire Marshal's Office

2 Martin Luther King Jr. Drive

Suite 920 / West Tower

Atlanta, Georgia 30334

www.oci.ga.gov

Phone: 404-656-7087

SECTION AO602 EMERGENCY INSPECTION KIT^b

- | | | |
|--|---|---|
| <input type="checkbox"/> Staff's disaster response management plan | <input type="checkbox"/> Safety glasses | <input type="checkbox"/> Duct tape |
| <input type="checkbox"/> Team contact list | <input type="checkbox"/> Sunglasses | <input type="checkbox"/> Staples & stapler |
| <input type="checkbox"/> Area maps | <input type="checkbox"/> Pocket knife | <input type="checkbox"/> Staple gun |
| <input type="checkbox"/> Official identification | <input type="checkbox"/> Matches | <input type="checkbox"/> Calculator |
| <input type="checkbox"/> Personal identification | <input type="checkbox"/> Antibacterial hand wipes or alcohol-based hand sanitizer | <input type="checkbox"/> Tire repair kit |
| <input type="checkbox"/> Inspection forms and placards | <input type="checkbox"/> Insect repellent (w/ Deet or Picaridin) | <i>Remember to grab:</i> |
| <input type="checkbox"/> Communication equipment | <input type="checkbox"/> Sunscreen (SPF 15 or greater) | <input type="checkbox"/> Personal identification |
| <input type="checkbox"/> Clipboard | <input type="checkbox"/> Camera | <input type="checkbox"/> Rain gear, extra clothing |
| <input type="checkbox"/> Hard hat | <input type="checkbox"/> Black markers | <input type="checkbox"/> Water bottle |
| <input type="checkbox"/> Orange safety vest | <input type="checkbox"/> Pens & pencils | <input type="checkbox"/> Prescription medication |
| <input type="checkbox"/> Dust mask | <input type="checkbox"/> Envelope for expense receipts | <input type="checkbox"/> Cell phone and charger |
| <input type="checkbox"/> Work gloves | <input type="checkbox"/> Compass, GPS unit | <input type="checkbox"/> Cash for personal expenses |
| <input type="checkbox"/> Steel toe and waterproof boots | <input type="checkbox"/> Backpack, waistpack | <input type="checkbox"/> Toiletries |
| <input type="checkbox"/> Whistle | <input type="checkbox"/> Flashlight and extra batteries | |
| <input type="checkbox"/> First aid kit | <input type="checkbox"/> Battery-operated radio | |
| <input type="checkbox"/> Latex gloves | | |

(b) *Disaster Mitigation: A Guide for Building Departments* by the International Code Council, Inc., copyright 2009

SECTION AO603
SAFETY TIPS ^a

1. Always travel in teams of at least two people.
2. Always wear a hard hat, gloves, goggles, safety vest, and dust masks.
3. Always wear safety shoes capable of protecting the toes and bottom of the foot.
4. Survey the building exterior completely before entering.
5. Enter building only if authorized and if deemed safe to do so.
6. Be alert for falling objects.
7. In case of fire, injuries or victims, evacuate the area and alert the fire department immediately.
8. Avoid downed power lines and buildings under them or water surrounding them.
9. In case of gas leaks, shut off the gas (if possible) and report the leak.
10. In a flood situation, have a “walking stick.”

(a) *When Disaster Strikes* by the International Code Council, Inc., Seventh Printing: November 2011, copyright 2007

SECTION AO604
MAJOR DISASTER PROCESS

(from link <https://www.fema.gov/disaster-declaration-process>)

A Major Disaster Declaration usually follows these steps:

- **Incident occurs and local government responds**, supplemented by neighboring communities and volunteer agencies. If overwhelmed, turn to the state for assistance;

Generally the local government will issue a local state of emergency

- **The State responds** with state resources, such as the National Guard and state agencies;

Prior to committing state resources, the Governor will declare a state of emergency in the counties impacted by the event for which assistance is needed.

- **Damage assessment** by local, state, federal, and volunteer organizations determine losses and recovery needs;

Generally the locals will submit a preliminary damage assessment to the state and the state will review and determine if state and/or federal assistance is needed. If federal assistance is needed, the state will request FEMA perform a preliminary joint damage assessment. If the Governor determines that the incident is of such severity and magnitude that effective response is beyond the capabilities of the state and the affected local governments then supplementary Federal assistance is requested (next step).

- **A Major Disaster Declaration** is requested by the Governor, based on the damage assessment, and agreement to commit state funds and resources to the long-term recovery;
- **FEMA evaluates** the request and recommends action to the White House based on the disaster, the local community and the state’s ability to recover;
- **The President approves** the request or FEMA informs the Governor it has been denied. This decision process could take a few hours or several weeks depending on the nature of the disaster.

SECTION AO605
SAMPLE EVALUATION FORMS AND INSPECTION PLACARDS ^b (following pages)

Figure AO605.1^b

ATC-45 Rapid Evaluation Safety Assessment Form

Inspection

Inspector ID: _____ Inspection date: _____

Affiliation: _____ Inspection time: _____ AM PM

Areas inspected: Exterior only Exterior and interior

Building Description

Building name: _____ Address: _____

Building contact/phone: _____

Number of stories: _____

"Footprint area" (square feet): _____

Number of residential units: _____

Type of Building

Mid-rise or high-rise Pre-fabricated

Low-rise multi-family One- or two-family dwelling

Low-rise commercial

Primary Occupancy

Dwelling Commercial Government

Other residential Offices Historic

Public assembly Industrial School

Emergency services Other: _____

Evaluation

Investigate the building for the conditions below and check the appropriate column. **Estimated Building Damage (excluding contents)**

Observed Conditions:	Minor/None	Moderate	Severe	Estimated Building Damage (excluding contents)
Collapse, partial collapse, or building off foundation	<input type="checkbox"/>	<input type="checkbox"/>	<input type="checkbox"/>	<input type="checkbox"/> None
Building significantly out of plumb or in danger	<input type="checkbox"/>	<input type="checkbox"/>	<input type="checkbox"/>	<input type="checkbox"/> > 0 to < 1%
Damage to primary structural members, racking of walls	<input type="checkbox"/>	<input type="checkbox"/>	<input type="checkbox"/>	<input type="checkbox"/> 1 to < 10%
Falling hazard due to nonstructural damage	<input type="checkbox"/>	<input type="checkbox"/>	<input type="checkbox"/>	<input type="checkbox"/> 10 to < 30%
Geotechnical hazard, scour, erosion, slope failure, etc.	<input type="checkbox"/>	<input type="checkbox"/>	<input type="checkbox"/>	<input type="checkbox"/> 30 to < 70%
Electrical lines / fixtures submerged / leaning trees	<input type="checkbox"/>	<input type="checkbox"/>	<input type="checkbox"/>	<input type="checkbox"/> 70 to < 100%
Other (specify) _____	<input type="checkbox"/>	<input type="checkbox"/>	<input type="checkbox"/>	<input type="checkbox"/> 100%

See back of form for further comments.

Posting

Choose a posting based on the evaluation and team judgment. Severe conditions endangering the overall building are grounds for an Unsafe posting. Localized Severe and overall Moderate conditions may allow a Restricted Use posting.

INSPECTED (Green placard) **RESTRICTED USE** (Yellow placard) **UNSAFE** (Red placard)

Record any use and entry restrictions exactly as written on placard: _____

Number of residential units vacated: _____

Further Actions Check the boxes below only if further actions are needed.

Barricades needed in the following areas: _____

Detailed Evaluation recommended: Structural Geotechnical Other: _____

Substantial Damage determination recommended

Other recommendations: _____

See back of form for further comments.

© Copyright 2004-07, Applied Technology Council. Permission is granted for unlimited, non-exclusive, non-commercial use and distribution of ATC evaluation forms, provided that this Copyright Notice appears on all copies and the Applied Technology Council name shall not be used in any advertising or publicity of Licensee product. Permission is further subject to the following conditions: (1) Licensee does not reprint, repackage or offer this form for sale or license; and (2) no material gain or financial profit is to be made from any sale or license of this form. Placards may be used without restrictions for their intended use as building postings. All rights not specifically granted to Licensee are herein reserved by ATC.

Figure AO605.2^b

ATC-45 Detailed Evaluation Safety Assessment Form

Inspection

Inspector ID: _____ Inspection date: _____

Affiliation: _____ Inspection time: _____ AM PM

Final Posting
from page 2

Inspected

Restricted Use

Unsafe

Building Description

Building name: _____

Address: _____

Building contact/phone: _____

Number of stories: _____

"Footprint area" (square feet): _____

Number of residential units: _____

Type of Building

Mid-rise or High-rise

Low-rise multi-family

Low-rise commercial

Pre-fabricated

One- or two-family dwelling

Other: _____

Primary Occupancy

Dwelling

Other residential

Public assembly

Emergency services

Commercial

Offices

Industrial

Other: _____

Government

Historic

School

Evaluation

Investigate the building for the conditions below and check the appropriate column. There is room on the second page for a sketch.

	Minor/None	Moderate	Severe	Comments
Overall hazards:				
Collapse or partial collapse	<input type="checkbox"/>	<input type="checkbox"/>	<input type="checkbox"/>	_____
Building or story lean or drift	<input type="checkbox"/>	<input type="checkbox"/>	<input type="checkbox"/>	_____
Fractured or displaced foundation	<input type="checkbox"/>	<input type="checkbox"/>	<input type="checkbox"/>	_____
Structural hazards:				
Failure of significant element/connection	<input type="checkbox"/>	<input type="checkbox"/>	<input type="checkbox"/>	_____
Column, pier, or bearing wall	<input type="checkbox"/>	<input type="checkbox"/>	<input type="checkbox"/>	_____
Roof/floor framing or connection	<input type="checkbox"/>	<input type="checkbox"/>	<input type="checkbox"/>	_____
Superstructure/foundation connection	<input type="checkbox"/>	<input type="checkbox"/>	<input type="checkbox"/>	_____
Moment frame	<input type="checkbox"/>	<input type="checkbox"/>	<input type="checkbox"/>	_____
Diaphragm/horizontal bracing	<input type="checkbox"/>	<input type="checkbox"/>	<input type="checkbox"/>	_____
Vertical bracing	<input type="checkbox"/>	<input type="checkbox"/>	<input type="checkbox"/>	_____
Shear wall	<input type="checkbox"/>	<input type="checkbox"/>	<input type="checkbox"/>	_____
Nonstructural hazards:				
Parapets, ornamentation	<input type="checkbox"/>	<input type="checkbox"/>	<input type="checkbox"/>	_____
Canopy	<input type="checkbox"/>	<input type="checkbox"/>	<input type="checkbox"/>	_____
Cladding, glazing	<input type="checkbox"/>	<input type="checkbox"/>	<input type="checkbox"/>	_____
Ceilings, light fixtures	<input type="checkbox"/>	<input type="checkbox"/>	<input type="checkbox"/>	_____
Stairs, exits, access walkways, gratings	<input type="checkbox"/>	<input type="checkbox"/>	<input type="checkbox"/>	_____
Interior walls, partitions	<input type="checkbox"/>	<input type="checkbox"/>	<input type="checkbox"/>	_____
Mechanical & electrical equipment	<input type="checkbox"/>	<input type="checkbox"/>	<input type="checkbox"/>	_____
Elevators	<input type="checkbox"/>	<input type="checkbox"/>	<input type="checkbox"/>	_____
Building contents, other _____	<input type="checkbox"/>	<input type="checkbox"/>	<input type="checkbox"/>	_____
Geotechnical hazards:				
Slope failure, debris impact	<input type="checkbox"/>	<input type="checkbox"/>	<input type="checkbox"/>	_____
Ground movement, erosion, sedimentation	<input type="checkbox"/>	<input type="checkbox"/>	<input type="checkbox"/>	_____
Differential settlement	<input type="checkbox"/>	<input type="checkbox"/>	<input type="checkbox"/>	_____

Continue on page 2

Georgia International Building Code Appendix O Disaster Resilient Construction

19

Figure AO605.3 b

INSPECTED

LAWFUL OCCUPANCY PERMITTED

This structure has been inspected (as indicated below) and no apparent structural hazard has been found.

Inspected Exterior Only

Inspected Exterior and Interior

Report any unsafe condition to local authorities; reinspection may be required.

Inspector Comments:

Facility Name and Address:

Date _____

Time _____

This facility was inspected under emergency conditions for:

_____ (Jurisdiction)

Inspector ID / Agency

**Do Not Remove, Alter, or Cover this Placard
until Authorized by Governing Authority**

Figure AO605.4^b

RESTRICTED USE

Caution: This structure has been inspected and found to be damaged as described below:

Entry, occupancy, and lawful use are restricted as indicated below:

- Do not enter the following areas: _____
- Brief entry allowed for access to contents: _____
- Other restrictions: _____

Facility name and address:

Date _____
Time _____

This facility was inspected under emergency conditions for:

(Jurisdiction)

Inspector ID / Agency

**Do Not Remove, Alter, or Cover this Placard
until Authorized by Governing Authority**

Figure AO605.5^b

UNSAFE

**DO NOT ENTER OR OCCUPY
(THIS PLACARD IS NOT A DEMOLITION ORDER)**

This structure has been inspected, found to be seriously damaged and is unsafe to occupy, as described below:

Do not enter, except as specifically authorized in writing by jurisdiction. Entry may result in death or injury.

Facility Name and Address:

Date _____
Time _____

This facility was inspected under emergency conditions for:

(Jurisdiction)

Inspector ID / Agency

**Do Not Remove, Alter, or Cover this Placard
until Authorized by Governing Authority**

CHAPTER AO7 REFERENCES

REFERENCED STANDARDS

ASCE Standards ASCE/SEI 24-14 Flood Resistant Design and Construction
 FEMA P-320, Fourth Edition / December 2014 Taking Shelter From the Storm: Building a Safe Room For Your Home or Small Business, Includes Construction Plans and Cost Estimates
 FEMA 361, Third Edition / March 2015 Design and Construction Guidance for Community Safe Rooms
 FEMA P-431, Second Edition/October 2009 Tornado Protection: Selecting Refuge Areas in Buildings
 FEMA Technical Bulletin 2, Table 2. Types, Uses, and Classifications of Materials

REFERENCED RESOURCES

- (a) *When Disaster Strikes* by the International Code Council, Inc., Seventh Printing: November 2011, copyright 2007
- (b) *Disaster Mitigation: A Guide for Building Departments* by the International Code Council, Inc., copyright 2009

INDEX OF FIGURES:

Figure AO103.3	Post Disaster Building Safety Evaluation Chart ^a	10
Figure AO605.1	ATC-45 Rapid Evaluation Form	18
Figure AO605.2	ATC-45 Detail Evaluation Form	19
Figure AO605.3	Inspected Placard	21
Figure AO605.4	Restricted Placard	22
Figure AO605.5	Unsafe Placard	23

INDEX

<p>B</p> <p>Best available refuge area Chapter 5, AO501.1, AO502.2, AO503</p> <p>C</p> <p>Connectors AO303.3</p> <p>Conventional Light-Frame Construction AO401.2.3</p> <p>E</p> <p>Emergency operation centers AO504.1</p> <p>Enclosure classification AO403.3</p> <p>Essential Facility AO103.3</p> <p>Evaluation</p> <p style="padding-left: 20px;">Detailed AO103.2.1, AO103.3.2.2, AO103.4</p> <p style="padding-left: 20px;">Engineering AO103.2.2, AO103.2.3, Figure 103.3</p> <p style="padding-left: 20px;">Rapid AO103.2.1, AO103.4, Figure AO605.1</p> <p>Exposure AO403.2</p> <p>F</p> <p>Fasteners AO303.3</p> <p>Flood</p> <p style="padding-left: 20px;">500-Year Chapter 2, AO302.1.2, AO302.1.3, AO302.1.4</p> <p style="padding-left: 20px;">Base Chapter 2, AO302.1.1</p> <p style="padding-left: 20px;">Design Chapter 2</p> <p style="padding-left: 20px;">Future-conditions Chapter 2, AO302.1.1, AO302.1.2, AO302.1.3, AO302.1.4</p> <p>Flood Elevation</p> <p style="padding-left: 20px;">Advisory Base ...Chapter 2, AO302.1.2, AO302.1.3, AO302.1.4</p> <p style="padding-left: 20px;">BaseChapter 2, AO302.1.2, AO302.1.3, AO302.1.4</p> <p style="padding-left: 20px;">DesignChapter 2, AO302.1.2, AO302.1.3, AO302.1.4</p> <p style="padding-left: 20px;">Futures-conditions Chapter 2</p> <p>Flood Hazard Area ..AO102.1.1, Chapter 2, AO301.1, AO302.1, AO302.1.1</p> <p>Flood-(Damage)Resistant MaterialChapter 2, AO303</p> <p>FreeboardChapter 2, Chapter 3</p>	<p>G</p> <p>Grade Schools AO504</p> <p>I</p> <p>Impact Resistant AO404.2, AO405.2, AO406.2</p> <p>Inspections AO103.1, AO103.2</p> <p>M</p> <p>Masonry</p> <p style="padding-left: 20px;">Empirical AO401.2.1</p> <p style="padding-left: 20px;">Unreinforced AO401.2.2</p> <p>O</p> <p>Opening Protection AO401.1, AO404.2, AO405.2, AO406.2</p> <p>P</p> <p>Placards AO103.2.1, AO103.5, Figure AO605.3-AO605.5</p> <p>S</p> <p>Safe rooms</p> <p style="padding-left: 20px;">Community AO502.2</p> <p style="padding-left: 20px;">Occupant density AO501.2, AO503.2</p> <p style="padding-left: 20px;">Residential AO501.1, AO502, AO502.2</p> <p>Sample OrdinancePage 2,3,and 4</p> <p>Storm sheltersAO101.3.3, Table AO401.1, Chapter AO5</p> <p>Substantial alterationsAO102.1.1</p> <p>Substantial improvementsAO101.3.1, AO302.1.1</p> <p>T</p> <p>Table of ContentsPage 7</p> <p>U</p> <p>Ultimate design wind speedAO404.1, AO405.1, AO406.1</p> <p>V</p> <p>ViolationsAO101.4</p> <p>W</p> <p>Wind Directionality FactorAO403.1</p> <p>Wind LoadAO401, AO403, AO404, AO405, AO406</p>
--	--

CHAPTER 34

EXISTING BUILDINGS AND STRUCTURES

SECTION 3401 GENERAL

3401.1 Scope. The provisions of this chapter shall control the *alteration, repair, addition* and change of occupancy of existing buildings and structures.

Exception: Existing *bleachers*, grandstands and folding and telescopic seating shall comply with ICC 300.

3401.2 Maintenance. Buildings and structures, and parts thereof, shall be maintained in a safe and sanitary condition. Devices or safeguards which are required by this code shall be maintained in conformance with the code edition under which installed. The owner or the owner's designated agent shall be responsible for the maintenance of buildings and structures. To determine compliance with this subsection, the *building official* shall have the authority to require a building or structure to be reinspected. The requirements of this chapter shall not provide the basis for removal or abrogation of fire protection and safety systems and devices in existing structures.

3401.3 Compliance. *Alterations, repairs, additions* and changes of occupancy to, or relocation of, existing buildings and structures shall comply with the provisions for *alterations, repairs, additions* and changes of occupancy or relocation, respectively, in the *International Energy Conservation Code, International Fire Code, International Fuel Gas Code, International Mechanical Code, International Plumbing Code, International Property Maintenance Code, International Private Sewage Disposal Code, International Residential Code* and NFPA 70. Where provisions of the other codes conflict with provisions of this chapter, the provisions of this chapter shall take precedence.

3401.4 Building materials and systems. Building materials and systems shall comply with the requirements of this section.

3401.4.1 Existing materials. Materials already in use in a building in compliance with requirements or approvals in effect at the time of their erection or installation shall be permitted to remain in use unless determined by the *building official* to be unsafe per Section 116.

3401.4.2 New and replacement materials. Except as otherwise required or permitted by this code, materials permitted by the applicable code for new construction shall be used. Like materials shall be permitted for repairs and alterations, provided no hazard to life, health or property is created. Hazardous materials shall not be used where the code for new construction would not *permit* their use in buildings of similar occupancy, purpose and location.

3401.4.3 Existing seismic force-resisting systems. Where the existing seismic force-resisting system is a type that can be designated ordinary, values of R , Ω_0 , and C_d for

the existing seismic force-resisting system shall be those specified by this code for an ordinary system unless it is demonstrated that the existing system will provide performance equivalent to that of a detailed, intermediate or special system.

3401.5 Dangerous conditions. The *building official* shall have the authority to require the elimination of conditions deemed *dangerous*.

3401.6 Alternative compliance. Work performed in accordance with the *International Existing Building Code* shall be deemed to comply with the provisions of this chapter.

SECTION 3402 DEFINITIONS

3402.1 Definitions. The following terms are defined in Chapter 34.

DANGEROUS.

EXISTING STRUCTURE.

PRIMARY FUNCTION.

SUBSTANTIAL STRUCTURAL DAMAGE.

TECHNICALLY INFEASIBLE.

SECTION 3403 ADDITIONS

3403.1 General. *Additions* to any building or structure shall comply with the requirements of this code for new construction. *Alterations* to the existing building or structure shall be made to ensure that the existing building or structure together with the *addition* are no less conforming with the provisions of this code than the existing building or structure was prior to the *addition*. An existing building together with its *additions* shall comply with the height and area provisions of Chapter 5.

3403.2 Flood hazard areas. For buildings and structures in *flood hazard areas* established in Section 1612.3, any *addition* that constitutes *substantial improvement* of the *existing structure*, as defined in Section 202, shall comply with the flood design requirements for new construction, and all aspects of the *existing structure* shall be brought into compliance with the requirements for new construction for flood design.

For buildings and structures in *flood hazard areas* established in Section 1612.3, any additions that do not constitute *substantial improvement* of the *existing structure*, as defined in Section 202, are not required to comply with the flood design requirements for new construction.

3403.3 Existing structural elements carrying gravity load.

Any existing gravity load-carrying structural element for which an *addition* and its related alterations cause an increase in design gravity load of more than 5 percent shall be strengthened, supplemented, replaced or otherwise altered as needed to carry the increased gravity load required by this code for new structures. Any existing gravity load-carrying structural element whose gravity load-carrying capacity is decreased shall be considered an altered element subject to the requirements of Section 3404.3. Any existing element that will form part of the lateral load path for any part of the *addition* shall be considered an existing lateral load-carrying structural element subject to the requirements of Section 3403.4.

3403.3.1 Design live load. Where the *addition* does not result in increased design live load, existing gravity load-carrying structural elements shall be permitted to be evaluated and designed for live loads *approved* prior to the *addition*. If the *approved* live load is less than that required by Section 1607, the area designed for the non-conforming live load shall be posted with placards of *approved* design indicating the *approved* live load. Where the *addition* does result in increased design live load, the live load required by Section 1607 shall be used.

3403.4 Existing structural elements carrying lateral load.

Where the *addition* is structurally independent of the *existing structure*, existing lateral load-carrying structural elements shall be permitted to remain unaltered. Where the *addition* is not structurally independent of the *existing structure*, the *existing structure* and its *addition* acting together as a single structure shall be shown to meet the requirements of Sections 1609 and 1613.

Exception: Any existing lateral load-carrying structural element whose demand-capacity ratio with the *addition* considered is no more than 10 percent greater than its demand-capacity ratio with the *addition* ignored shall be permitted to remain unaltered. For purposes of calculating demand-capacity ratios, the demand shall consider applicable load combinations with design lateral loads or forces in accordance with Sections 1609 and 1613. For purposes of this exception, comparisons of demand-capacity ratios and calculation of design lateral loads, forces and capacities shall account for the cumulative effects of *additions* and *alterations* since original construction.

3403.5 Smoke alarms in existing portions of a building.

Where an *addition* is made to a building or structure of a Group R or I-1 occupancy, the existing building shall be provided with *smoke alarms* in accordance with Section 1103.8 of the *International Fire Code*.

SECTION 3404 ALTERATIONS

3404.1 General. Except as provided by Section 3401.4 or this section, *alterations* to any building or structure shall comply with the requirements of the code for new construction. *Alterations* shall be such that the existing building or structure is no less complying with the provisions of this code

than the existing building or structure was prior to the *alteration*.

Exceptions:

1. An existing *stairway* shall not be required to comply with the requirements of Section 1011 where the existing space and construction does not allow a reduction in pitch or slope.
2. *Handrails* otherwise required to comply with Section 1011.11 shall not be required to comply with the requirements of Section 1014.6 regarding full extension of the *handrails* where such extensions would be hazardous due to plan configuration.

3404.2 Flood hazard areas. For buildings and structures in *flood hazard areas* established in Section 1612.3, any *alteration* that constitutes *substantial improvement* of the *existing structure*, as defined in Section 202, shall comply with the flood design requirements for new construction, and all aspects of the *existing structure* shall be brought into compliance with the requirements for new construction for flood design.

For buildings and structures in *flood hazard areas* established in Section 1612.3, any *alterations* that do not constitute *substantial improvement* of the *existing structure*, as defined in Section 202, are not required to comply with the flood design requirements for new construction.

3404.3 Existing structural elements carrying gravity load.

Any existing gravity load-carrying structural element for which an *alteration* causes an increase in design gravity load of more than 5 percent shall be strengthened, supplemented, replaced or otherwise altered as needed to carry the increased gravity load required by this code for new structures. Any existing gravity load-carrying structural element whose gravity load-carrying capacity is decreased as part of the *alteration* shall be shown to have the capacity to resist the applicable design gravity loads required by this code for new structures.

3404.3.1 Design live load. Where the *alteration* does not result in increased design live load, existing gravity load-carrying structural elements shall be permitted to be evaluated and designed for live loads *approved* prior to the *alteration*. If the *approved* live load is less than that required by Section 1607, the area designed for the non-conforming live load shall be posted with placards of *approved* design indicating the *approved* live load. Where the *alteration* does result in increased design live load, the live load required by Section 1607 shall be used.

3404.4 Existing structural elements carrying lateral load.

Except as permitted by Section 3404.5, where the *alteration* increases design lateral loads in accordance with Section 1609 or 1613, or where the *alteration* results in a structural irregularity as defined in ASCE 7, or where the *alteration* decreases the capacity of any existing lateral load-carrying structural element, the structure of the altered building or structure shall be shown to meet the requirements of Sections 1609 and 1613.

Exception: Any existing lateral load-carrying structural element whose demand-capacity ratio with the *alteration*

considered is no more than 10 percent greater than its demand-capacity ratio with the *alteration* ignored shall be permitted to remain unaltered. For purposes of calculating demand-capacity ratios, the demand shall consider applicable load combinations with design lateral loads or forces per Sections 1609 and 1613. For purposes of this exception, comparisons of demand-capacity ratios and calculation of design lateral loads, forces, and capacities shall account for the cumulative effects of *additions* and *alterations* since original construction.

3404.5 Voluntary seismic improvements. *Alterations* to existing structural elements or additions of new structural elements that are not otherwise required by this chapter and are initiated for the purpose of improving the performance of the seismic force-resisting system of an *existing structure* or the performance of seismic bracing or anchorage of existing nonstructural elements shall be permitted, provided that an engineering analysis is submitted demonstrating the following:

1. The altered structure and the altered nonstructural elements are no less conforming with the provisions of this code with respect to earthquake design than they were prior to the alteration.
2. New structural elements are detailed as required for new construction.
3. New or relocated nonstructural elements are detailed and connected to existing or new structural elements as required for new construction.
4. The alterations do not create a structural irregularity as defined in ASCE 7 or make an existing structural irregularity more severe.

3404.6 Smoke alarms. Individual *sleeping units* and individual *dwelling units* in Group R and I-1 occupancies shall be provided with *smoke alarms* in accordance with Section 1103.8 of the *International Fire Code*.

SECTION 3405 REPAIRS

3405.1 General. Buildings and structures, and parts thereof, shall be repaired in compliance with Section 3405 and 3401.2. Work on nondamaged components that is necessary for the required *repair* of damaged components shall be considered part of the *repair* and shall not be subject to the requirements for *alterations* in this chapter. Routine maintenance required by Section 3401.2, ordinary repairs exempt from *permit* in accordance with Section 105.2, and abatement of wear due to normal service conditions shall not be subject to the requirements for *repairs* in this section.

3405.2 Substantial structural damage to vertical elements of the lateral force-resisting system. A building that has sustained *substantial structural damage* to the vertical elements of its lateral force-resisting system shall be evaluated and repaired in accordance with the applicable provisions of Sections 3405.2.1 through 3405.2.3.

Exceptions:

1. Buildings assigned to *Seismic Design Category A*, *B*, or *C* whose *substantial structural damage* was

not caused by earthquake need not be evaluated or rehabilitated for load combinations that include earthquake effects.

2. One- and two-family dwellings need not be evaluated or rehabilitated for load combinations that include earthquake effects.

3405.2.1 Evaluation. The building shall be evaluated by a *registered design professional*, and the evaluation findings shall be submitted to the *building official*. The evaluation shall establish whether the damaged building, if repaired to its pre-damage state, would comply with the provisions of this code for wind and earthquake loads.

Wind loads for this evaluation shall be those prescribed in Section 1609. Earthquake loads for this evaluation, if required, shall be permitted to be 75 percent of those prescribed in Section 1613.

3405.2.2 Extent of repair for compliant buildings. If the evaluation establishes compliance of the pre-damage building in accordance with Section 3405.2.1, then repairs shall be permitted that restore the building to its pre-damage state based on material properties and design strengths applicable at the time of original construction.

3405.2.3 Extent of repair for noncompliant buildings. If the evaluation does not establish compliance of the pre-damage building in accordance with Section 3404.2.1, then the building shall be rehabilitated to comply with applicable provisions of this code for load combinations that include wind or seismic loads. The wind loads for the repair shall be as required by the building code in effect at the time of original construction, unless the damage was caused by wind, in which case the wind loads shall be as required by this code. Earthquake loads for this rehabilitation design shall be those required for the design of the pre-damage building, but not less than 75 percent of those prescribed in Section 1613. New structural members and connections required by this rehabilitation design shall comply with the detailing provisions of this code for new buildings of similar structure, purpose and location.

3405.3 Substantial structural damage to gravity load-carrying components. Gravity load-carrying components that have sustained *substantial structural damage* shall be rehabilitated to comply with the applicable provisions of this code for dead and live loads. Snow loads shall be considered if the *substantial structural damage* was caused by or related to snow load effects. Existing gravity load-carrying structural elements shall be permitted to be designed for live loads *approved* prior to the damage. Nondamaged gravity load-carrying components that receive dead, live or snow loads from rehabilitated components shall also be rehabilitated or shown to have the capacity to carry the design loads of the rehabilitation design. New structural members and connections required by this rehabilitation design shall comply with the detailing provisions of this code for new buildings of similar structure, purpose and location.

3405.3.1 Lateral force-resisting elements. Regardless of the level of damage to vertical elements of the lateral force-resisting system, if *substantial structural damage* to gravity load-carrying components was caused primarily by

wind or earthquake effects, then the building shall be evaluated in accordance with Section 3405.2.1 and, if noncompliant, rehabilitated in accordance with Section 3405.2.3.

Exceptions:

1. One- and two-family dwellings need not be evaluated or rehabilitated for load combinations that include earthquake effects.
2. Buildings assigned to *Seismic Design Category A, B, or C* whose *substantial structural damage* was not caused by earthquake need not be evaluated or rehabilitated for load combinations that include earthquake effects.

3405.4 Less than substantial structural damage. For damage less than *substantial structural damage*, repairs shall be allowed that restore the building to its pre-damage state, based on material properties and design strengths applicable at the time of original construction. New structural members and connections used for this repair shall comply with the detailing provisions of this code for new buildings of similar structure, purpose and location.

3405.5 Flood hazard areas. For buildings and structures in *flood hazard areas* established in Section 1612.3, any repair that constitutes *substantial improvement* of the *existing structure*, as defined in Section 202, shall comply with the flood design requirements for new construction, and all aspects of the *existing structure* shall be brought into compliance with the requirements for new construction for flood design.

For buildings and structures in *flood hazard areas* established in Section 1612.3, any repairs that do not constitute *substantial improvement* or *repair of substantial damage* of the *existing structure*, as defined in Section 202, are not required to comply with the flood design requirements for new construction.

SECTION 3406 FIRE ESCAPES

3406.1 Where permitted. Fire escapes shall be permitted only as provided for in Sections 3406.1.1 through 3406.1.4.

3406.1.1 New buildings. Fire escapes shall not constitute any part of the required *means of egress* in new buildings.

3406.1.2 Existing fire escapes. Existing fire escapes shall be continued to be accepted as a component in the *means of egress* in existing buildings only.

3406.1.3 New fire escapes. New fire escapes for existing buildings shall be permitted only where exterior *stairs* cannot be utilized due to lot lines limiting *stair* size or due to the sidewalks, alleys or roads at grade level. New fire escapes shall not incorporate ladders or access by windows.

3406.1.4 Limitations. Fire escapes shall comply with this section and shall not constitute more than 50 percent of the required number of *exits* nor more than 50 percent of the required *exit* capacity.

3406.2 Location. Where located on the front of the building and where projecting beyond the building line, the lowest landing shall not be less than 7 feet (2134 mm) or more than 12 feet (3658 mm) above grade, and shall be equipped with a counterbalanced stairway to the street. In alleyways and thoroughfares less than 30 feet (9144 mm) wide, the clearance under the lowest landing shall not be less than 12 feet (3658 mm).

3406.3 Construction. The fire escape shall be designed to support a live load of 100 pounds per square foot (4788 Pa) and shall be constructed of steel or other *approved* noncombustible materials. Fire escapes constructed of wood not less than nominal 2 inches (51 mm) thick are permitted on buildings of Type V construction. Walkways and railings located over or supported by combustible roofs in buildings of Type III and IV construction are permitted to be of wood not less than nominal 2 inches (51 mm) thick.

3406.4 Dimensions. *Stairs* shall be at least 22 inches (559 mm) wide with risers not more than, and treads not less than, 8 inches (203 mm) and landings at the foot of stairs not less than 40 inches (1016 mm) wide by 36 inches (914 mm) long, located not more than 8 inches (203 mm) below the door.

3406.5 Opening protectives. Doors and windows along the fire escape shall be protected with $\frac{3}{4}$ -hour opening protection.

SECTION 3407 GLASS REPLACEMENT

3407.1 Conformance. The installation or replacement of glass shall be as required for new installations.

SECTION 3408 CHANGE OF OCCUPANCY

3408.1 Conformance. No change shall be made in the use or occupancy of any building that would place the building in a different division of the same group of occupancies or in a different group of occupancies, unless such building is made to comply with the requirements of this code for such division or group of occupancies. Subject to the approval of the *building official*, the use or occupancy of existing buildings shall be permitted to be changed and the building is allowed to be occupied for purposes in other groups without conforming to all the requirements of this code for those groups, provided the new or proposed use is less hazardous, based on life and fire risk, than the existing use.

3408.2 Certificate of occupancy. A certificate of occupancy shall be issued where it has been determined that the requirements for the new occupancy classification have been met.

3408.3 Stairways. An existing *stairway* shall not be required to comply with the requirements of Section 1009 where the existing space and construction does not allow a reduction in pitch or slope.

3408.4 Seismic. When a change of occupancy results in a structure being reclassified to a higher risk category, the

structure shall conform to the seismic requirements for a new structure of the higher risk category.

Exceptions:

1. Specific seismic detailing requirements of Section 1613 for a new structure shall not be required to be met where the seismic performance is shown to be equivalent to that of a new structure. A demonstration of equivalence shall consider the regularity, overstrength, redundancy and ductility of the structure.
2. When a change of use results in a structure being reclassified from Risk Category I or II to Risk Category III and the structure is located where the seismic coefficient, S_{DS} , is less than 0.33, compliance with the seismic requirements of Section 1613 are not required.

SECTION 3409 HISTORIC BUILDINGS

3409.1 Historic buildings. The provisions of this code relating to the construction, *repair*, *alteration*, *addition*, restoration and movement of structures, and change of occupancy shall not be mandatory for *historic buildings* where such buildings are judged by the *building official* to not constitute a distinct life safety hazard.

3409.2 Flood hazard areas. Within *flood hazard areas* established in accordance with Section 1612.3, where the work proposed constitutes *substantial improvement* as defined in Section 202, the building shall be brought into compliance with Section 1612.

Exception: *Historic buildings* that are:

1. Listed or preliminarily determined to be eligible for listing in the National Register of Historic Places;
2. Determined by the Secretary of the U.S. Department of Interior as contributing to the historical significance of a registered historic district or a district preliminarily determined to qualify as an historic district; or
3. Designated as historic under a state or local historic preservation program that is *approved* by the Department of Interior.

SECTION 3410 MOVED STRUCTURES

3410.1 Conformance. Structures moved into or within the jurisdiction shall comply with the provisions of this code for new structures.

SECTION 3411 ACCESSIBILITY FOR EXISTING BUILDINGS

3411.1 Scope. The provisions of Sections 3411.1 through 3411.9 apply to maintenance, change of occupancy, *additions*

and *alterations* to existing buildings, including those identified as *historic buildings*.

3411.2 Maintenance of facilities. A *facility* that is constructed or altered to be *accessible* shall be maintained *accessible* during occupancy.

3411.3 Extent of application. An *alteration* of an existing *facility* shall not impose a requirement for greater accessibility than that which would be required for new construction. *Alterations* shall not reduce or have the effect of reducing accessibility of a *facility* or portion of a *facility*.

3411.4 Change of occupancy. Existing buildings that undergo a change of group or occupancy shall comply with this section.

Exception: *Type B dwelling units* or *sleeping units* required by Section 1107 of this code are not required to be provided in existing buildings and facilities undergoing a change of occupancy in conjunction with *alterations* where the work area is 10 percent or less of the aggregate area of the building.

3411.4.1 Partial change in occupancy. Where a portion of the building is changed to a new occupancy classification, any *alterations* shall comply with Sections 3411.6, 3411.7 and 3411.8.

3411.4.2 Complete change of occupancy. Where an entire building undergoes a change of occupancy, it shall comply with Section 3411.4.1 and shall have all of the following *accessible* features:

1. At least one *accessible* building entrance.
2. At least one *accessible route* from an *accessible* building entrance to *primary function* areas.
3. Signage complying with Section 1113.
4. *Accessible* parking, where parking is being provided.
5. At least one *accessible* passenger loading zone, when loading zones are provided.
6. At least one *accessible route* connecting *accessible* parking and *accessible* passenger loading zones to an *accessible* entrance.

Where it is *technically infeasible* to comply with the new construction standards for any of these requirements for a change of group or occupancy, the above items shall conform to the requirements to the maximum extent *technically feasible*.

Exception: The *accessible* features listed in Items 1 through 6 are not required for an *accessible* route to *Type B units*.

3411.5 Additions. Provisions for new construction shall apply to *additions*. An *addition* that affects the accessibility to, or contains an area of, a *primary function* shall comply with the requirements in Section 3411.7.

3411.6 Alterations. A *facility* that is altered shall comply with the applicable provisions in Chapter 11 of this code, unless *technically infeasible*. Where compliance with this

section is *technically infeasible*, the *alteration* shall provide access to the maximum extent technically feasible.

Exceptions:

1. The altered element or space is not required to be on an *accessible route*, unless required by Section 3411.7.
2. *Accessible means of egress* required by Chapter 10 are not required to be provided in existing facilities.
3. The *alteration* to *Type A* individually owned *dwelling units* within a Group R-2 occupancy shall be permitted to meet the provision for a *Type B dwelling unit*.
4. *Type B dwelling* or *sleeping units* required by Section 1107 of this code are not required to be provided in existing buildings and facilities undergoing a change of occupancy in conjunction with *alterations* where the work area is 50 percent or less of the aggregate area of the building.

3411.7 Alterations affecting an area containing a primary function. Where an *alteration* affects the accessibility to, or contains an area of *primary function*, the route to the *primary function* area shall be *accessible*. The *accessible route* to the *primary function* area shall include toilet facilities or drinking fountains serving the area of *primary function*.

Exceptions:

1. The costs of providing the *accessible route* are not required to exceed 20 percent of the costs of the *alterations* affecting the area of *primary function*.
2. This provision does not apply to *alterations* limited solely to windows, hardware, operating controls, electrical outlets and signs.
3. This provision does not apply to *alterations* limited solely to mechanical systems, electrical systems, installation or alteration of fire protection systems and abatement of hazardous materials.
4. This provision does not apply to *alterations* undertaken for the primary purpose of increasing the accessibility of a *facility*.
5. This provision does not apply to altered areas limited to *Type B dwelling* and *sleeping units*.

3411.8 Scoping for alterations. The provisions of Sections 3411.8.1 through 3411.8.14 shall apply to *alterations* to existing buildings and facilities.

3411.8.1 Entrances. *Accessible* entrances shall be provided in accordance with Section 1105.

Exception: Where an *alteration* includes *alterations* to an entrance, and the *facility* has an *accessible* entrance, the altered entrance is not required to be *accessible*, unless required by Section 3411.7. Signs complying with Section 1113 shall be provided.

3411.8.2 Elevators. Altered elements of existing elevators shall comply with ASME A17.1 and ICC A117.1. Such elements shall also be altered in elevators programmed to respond to the same hall call control as the altered elevator.

3411.8.3 Platform lifts. Platform (wheelchair) lifts complying with ICC A117.1 and installed in accordance with ASME A18.1 shall be permitted as a component of an *accessible route*.

3411.8.4 Stairs and escalators in existing buildings. In *alterations*, change of occupancy or *additions* where an escalator or *stair* is added where none existed previously and major structural modifications are necessary for installation, an *accessible* route shall be provided between the levels served by the escalator or *stairs* in accordance with Sections 1104.4 and 1104.5.

3411.8.5 Ramps. Where slopes steeper than allowed by Section 1014.2 are necessitated by space limitations, the slope of ramps in or providing access to existing *facilities* shall comply with Table 3411.8.5.

TABLE 3411.8.5
RAMP SLOPES

SLOPE	MAXIMUM RISE
Steeper than 1:10 but not steeper than 1:8	3 inches
Steeper than 1:2 but not steeper than 1:10	6 inches

For SI: 1 in. = 25.4 mm.

3411.8.6 Performance areas. Where it is *technically infeasible* to alter performance areas to be on an *accessible route*, at least one of each type of performance area shall be made *accessible*.

3411.8.7 Accessible dwelling or sleeping units. Where Group I-1, I-2, I-3, R-1, R-2 or R-4 *dwelling* or *sleeping units* are being altered or added, the requirements of Section 1107 for *Accessible units* apply only to the quantity of spaces being altered or added.

3411.8.8 Type A dwelling or sleeping units. Where more than 20 Group R-2 *dwelling* or *sleeping units* are being altered or added, the requirements of Section 1107 for *Type A units* apply only to the quantity of the spaces being altered or added.

3411.8.9 Type B dwelling or sleeping units. Where four or more Group I-1, I-2, R-1, R-2, R-3 or R-4 *dwelling* or *sleeping units* are being added, the requirements of Section 1107 for *Type B units* apply only to the quantity of the spaces being added. Where Group I-1, I-2, R-1, R-2, R-3 or R-4 *dwelling* or *sleeping units* are being altered and where the work area is greater than 50 percent of the aggregate area of the building, the requirements of Section 1107 for *Type B units* apply only to the quantity of the spaces being altered.

3411.8.10 Jury boxes and witness stands. In *alterations*, *accessible* wheelchair spaces are not required to be located within the defined area of raised jury boxes or witness stands and shall be permitted to be located outside these spaces where the ramp or lift access restricts or projects into the *means of egress*.

3411.8.11 Toilet rooms. Where it is *technically infeasible* to alter existing toilet and bathing rooms to be *accessible*, an *accessible* family or assisted-use toilet or bathing room constructed in accordance with Section 1109.2.1 is permitted. The family or assisted-use toilet or bathing room shall

be located on the same floor and in the same area as the existing toilet or bathing rooms.

3411.8.12 Dressing, fitting and locker rooms. Where it is *technically infeasible* to provide *accessible* dressing, fitting or locker rooms at the same location as similar types of rooms, one *accessible* room on the same level shall be provided. Where separate-sex facilities are provided, *accessible* rooms for each sex shall be provided. Separate-sex facilities are not required where only unisex rooms are provided.

3411.8.13 Fuel dispensers. Operable parts of replacement fuel dispensers shall be permitted to be 54 inches (1370 mm) maximum measured from the surface of the vehicular way where fuel dispensers are installed on existing curbs.

3411.8.14 Thresholds. The maximum height of thresholds at doorways shall be $\frac{3}{4}$ inch (19.1 mm). Such thresholds shall have beveled edges on each side.

3411.9 Historic buildings. These provisions shall apply to facilities designated as historic structures that undergo *alterations* or a change of occupancy, unless *technically infeasible*. Where compliance with the requirements for *accessible routes*, entrances or toilet rooms would threaten or destroy the historic significance of the facility, as determined by the applicable governing authority, the alternative requirements of Sections 3411.9.1 through 3411.9.4 for that element shall be permitted.

Exception: *Type B dwelling* or *sleeping units* required by Section 1107 are not required to be provided in historical buildings.

3411.9.1 Site arrival points. At least one *accessible* route from a site arrival point to an *accessible* entrance shall be provided.

3411.9.2 Multilevel buildings and facilities. An *accessible route* from an *accessible* entrance to public spaces on the level of the *accessible* entrance shall be provided.

3411.9.3 Entrances. At least one main entrance shall be *accessible*.

Exceptions:

1. If a main entrance cannot be made *accessible*, an *accessible* nonpublic entrance that is unlocked while the building is occupied shall be provided; or
2. If a main entrance cannot be made *accessible*, a locked *accessible* entrance with a notification system or remote monitoring shall be provided.

Signs complying with Section 1113 shall be provided at the primary entrance and the *accessible* entrance.

3411.9.4 Toilet and bathing facilities. Where toilet rooms are provided, at least one *accessible* family or assisted-use toilet room complying with Section 1109.2.1 shall be provided.

SECTION 3412 COMPLIANCE ALTERNATIVES

3412.1 Compliance. The provisions of this section are intended to maintain or increase the current degree of public safety, health and general welfare in existing buildings while permitting repair, *alteration*, *addition* and change of occupancy without requiring full compliance with Chapters 2 through 33, or Sections 3401.3, and 3403 through 3409, except where compliance with other provisions of this code is specifically required in this section.

3412.2 Applicability. Structures existing prior to [DATE TO BE INSERTED BY THE JURISDICTION. NOTE: IT IS RECOMMENDED THAT THIS DATE COINCIDE WITH THE EFFECTIVE DATE OF BUILDING CODES WITHIN THE JURISDICTION], in which there is work involving *additions*, *alterations* or changes of occupancy shall be made to comply with the requirements of this section or the provisions of Sections 3403 through 3409. The provisions in Sections 3412.2.1 through 3412.2.5 shall apply to existing occupancies that will continue to be, or are proposed to be, in Groups A, B, E, F, M, R, S and U. These provisions shall not apply to buildings with occupancies in Group H or I.

3412.2.1 Change in occupancy. Where an existing building is changed to a new occupancy classification and this section is applicable, the provisions of this section for the new occupancy shall be used to determine compliance with this code.

3412.2.2 Partial change in occupancy. Where a portion of the building is changed to a new occupancy classification, and that portion is separated from the remainder of the building with *fire barriers* or *horizontal assemblies* having a *fire-resistance rating* as required by Table 508.4 for the separate occupancies, or with *approved* compliance alternatives, the portion changed shall be made to comply with the provisions of this section.

Where a portion of the building is changed to a new occupancy classification, and that portion is not separated from the remainder of the building with *fire barriers* or *horizontal assemblies* having a *fire-resistance rating* as required by Table 508.4 for the separate occupancies, or with *approved* compliance alternatives, the provisions of this section which apply to each occupancy shall apply to the entire building. Where there are conflicting provisions, those requirements which secure the greater public safety shall apply to the entire building or structure.

3412.2.3 Additions. *Additions* to existing buildings shall comply with the requirements of this code for new construction. The combined height and area of the existing building and the new *addition* shall not exceed the height and area allowed by Chapter 5. Where a *fire wall* that complies with Section 706 is provided between the *addition* and the existing building, the *addition* shall be considered a separate building.

3412.2.4 Alterations and repairs. An existing building or portion thereof, which does not comply with the requirements of this code for new construction, shall not be altered or repaired in such a manner that results in the building being less safe or sanitary than such building is currently. If, in the *alteration* or repair, the current level of safety or sanitation is to be reduced, the portion altered or repaired shall conform to the requirements of Chapters 2 through 12 and Chapters 14 through 33.

3412.2.4.1 Flood hazard areas. For existing buildings located in *flood hazard areas* established in Section 1612.3, if the *alterations* and *repairs* constitute *substantial improvement* of the existing building, the existing building shall be brought into compliance with the requirements for new construction for flood design.

3412.2.5 Accessibility requirements. All portions of the buildings proposed for change of occupancy shall conform to the accessibility provisions of Section 3411.

3412.3 Acceptance. For *repairs*, *alterations*, *additions* and changes of occupancy to existing buildings that are evaluated in accordance with this section, compliance with this section shall be accepted by the *building official*.

3412.3.1 Hazards. Where the *building official* determines that an unsafe condition exists, as provided for in Section 116, such unsafe condition shall be abated in accordance with Section 116.

3412.3.2 Compliance with other codes. Buildings that are evaluated in accordance with this section shall comply with the *International Fire Code* and the *International Property Maintenance Code*.

3412.4 Investigation and evaluation. For proposed work covered by this section, the building owner shall cause the existing building to be investigated and evaluated in accordance with the provisions of this section.

3412.4.1 Structural analysis. The owner shall have a structural analysis of the existing building made to determine adequacy of structural systems for the proposed *alteration*, *addition* or change of occupancy. The analysis shall demonstrate that the building with the work completed is capable of resisting the loads specified in Chapter 16.

3412.4.2 Submittal. The results of the investigation and evaluation as required in Section 3412.4, along with proposed compliance alternatives, shall be submitted to the *building official*.

3412.4.3 Determination of compliance. The *building official* shall determine whether the existing building, with the proposed *addition*, *alteration* or change of occupancy, complies with the provisions of this section in accordance with the evaluation process in Sections 3412.5 through 3412.9.

3412.5 Evaluation. The evaluation shall be comprised of three categories: fire safety, means of egress and general safety, as defined in Sections 3412.5.1 through 3412.5.3.

3412.5.1 Fire safety. Included within the fire safety category are the structural fire resistance, automatic fire detec-

tion, fire alarm, automatic sprinkler system and fire suppression system features of the facility.

3412.5.2 Means of egress. Included within the means of egress category are the configuration, characteristics and support features for *means of egress* in the facility.

3412.5.3 General safety. Included within the general safety category are the fire safety parameters and the means of egress parameters.

3412.6 Evaluation process. The evaluation process specified herein shall be followed in its entirety to evaluate existing buildings. Table 3412.7 shall be utilized for tabulating the results of the evaluation. References to other sections of this code indicate that compliance with those sections is required in order to gain credit in the evaluation herein outlined. In applying this section to a building with mixed occupancies, where the separation between the mixed occupancies does not qualify for any category indicated in Section 3412.6.16, the score for each occupancy shall be determined and the lower score determined for each section of the evaluation process shall apply to the entire building.

Where the separation between mixed occupancies qualifies for any category indicated in Section 3412.6.16, the score for each occupancy shall apply to each portion of the building based on the occupancy of the space.

3412.6.1 Building height. The value for building height shall be the lesser value determined by the formula in Section 3412.6.1.1. Chapter 5 shall be used to determine the allowable height of the building, including allowable increases due to automatic sprinklers as provided for in Section 504.2. Subtract the actual *building height* in feet from the allowable and divide by 12 1/2 feet. Enter the height value and its sign (positive or negative) in Table 3412.7 under Safety Parameter 3412.6.1, Building Height, for fire safety, means of egress and general safety. The maximum score for a building shall be 10.

3412.6.1.1 Height formula. The following formulas shall be used in computing the *building height* value.

$$\text{Height value, feet} = \frac{(AH) - (EBH)}{12.5} \times CF \quad (\text{Equation 34-1})$$

$$\text{Height value, feet} = (AS - EBS) \times CF \quad (\text{Equation 34-2})$$

where:

AH = Allowable height in feet from 2012 IBC Table 503.

EBH = Existing *building height* in feet.

AS = Allowable height in stories from 2012 IBC Table 503.

EBS = Existing *building height* in stories.

CF = 1 if $(AH) - (EBH)$ is positive.

CF = Construction-type factor shown in Table 3412.6.6(2) if $(AH) - (EBH)$ is negative.

Note: Where mixed occupancies are separated and individually evaluated as indicated in Section 3412.6,

the values AH, AS, EBH and EBS shall be based on the height of the occupancy being evaluated.

3412.6.2 Building area. The value for building area shall be determined by the formula in Section 3412.6.2.2. Section 503 and the formula in Section 3412.6.2.1 shall be used to determine the allowable area of the building. This shall include any allowable increases due to frontage and automatic sprinklers as provided for in Section 506. Subtract the actual *building area* in square feet from the allowable area and divide by 1,200 square feet. Enter the area value and its sign (positive or negative) in Table 3412.7 under Safety Parameter 3412.6.2, Building Area, for fire safety, means of egress and general safety. In determining the area value, the maximum permitted positive value for area is 50 percent of the fire safety score as listed in Table 3412.8, Mandatory Safety Scores.

3412.6.2.1 Allowable area formula. The following formula shall be used in computing allowable area:

$$A_a = [A_t + (A_t \times I_f) + (A_t \times I_s)] \quad \text{(Equation 34-3)}$$

where:

A_a = Allowable *building area* per story (square feet).

A_t = Tabular *building area* per story in accordance with 4234"IDE"Table 5050(square feet).

I_s = Area increase factor due to sprinkler protection as calculated in accordance with 4234"IDE"Section 506.5.

I_f = Area increase factor due to for frontage as calculated in accordance with 4234"IDE"Section 506.4D

3412.6.2.2 Area formula. The following formula shall be used in computing the area value. Determine the area value for each occupancy floor area on a floor-by-floor basis. For each occupancy, choose the maximum area value of the set of values obtained for the particular occupancy

$$\text{Area value } i = \frac{\text{Allowable area } i - \left[\frac{\text{Actual area } i}{\text{Allowable area } i} + \dots + \frac{\text{Actual area } n}{\text{Allowable area } n} \right]}{1,200 \text{ square feet}} \quad \text{(Equation 34-4)}$$

where:

i = Value for an individual separated occupancy on a floor.

n = Number of separated occupancies on a floor.

3412.6.3 Compartmentation. Evaluate the compartments created by *fire barriers* or *horizontal assemblies* which comply with Sections 3412.6.3.1 and 3412.6.3.2 and which are exclusive of the wall elements considered under Sections 3412.6.4 and 3412.6.5. Conforming compartments shall be figured as the net area and do not include shafts, chases, *stairways*, walls or columns. Using Table 3412.6.3, determine the appropriate compartmentation value (CV) and enter that value into Table 3412.7 under Safety Parameter 3412.6.3, Compartmentation, for fire safety, means of egress and general safety.

3412.6.3.1 Wall construction. A wall used to create separate compartments shall be a *fire barrier* conforming to Section 707 with a *fire-resistance rating* of not less than 2 hours. Where the building is not divided into more than one compartment, the compartment size shall be taken as the total floor area on all floors. Where there is more than one compartment within a *story*, each compartmented area on such *story* shall be provided with a *horizontal exit* conforming to Section 1028. The *fire door* serving as the *horizontal exit* between compartments shall be so installed, fitted and gasketed that such *fire door* will provide a substantial barrier to the passage of smoke.

3412.6.3.2 Floor/ceiling construction. A floor/ceiling assembly used to create compartments shall conform to Section 711 and shall have a *fire-resistance rating* of not less than 2 hours.

3412.6.4 Tenant and dwelling unit separations. Evaluate the *fire-resistance rating* of floors and walls separating tenants, including *dwelling units*, and not evaluated under Sections 3412.6.3 and 3412.6.5. Under the categories and occupancies in Table 3412.6.4, determine the appropriate value and enter that value in Table 3412.7 under Safety Parameter 3412.6.4, Tenant and Dwelling Unit Separations, for fire safety, means of egress and general safety.

TABLE 3412.6.4 SEPARATION VALUES

OCCUPANCY	CATEGORIES				
	a	b	c	d	e
A-1	0	0	0	0	1
A-2	-5	-3	0	1	3
A-3, A-4, B, E, F, M, S-1	-4	-3	0	2	4
R	-4	-2	0	2	4
S-2	-5	-2	0	2	4

3412.6.4.1 Categories. The categories for tenant and *dwelling unit* separations are:

1. Category a—No *fire partitions*; incomplete *fire partitions*; no doors; doors not self-closing or automatic-closing.
2. Category b—*Fire partitions* or floor assemblies with less than a 1-hour *fire-resistance rating* or not constructed in accordance with Sections 708 or 711.
3. Category c—*Fire partitions* with a 1-hour or greater *fire-resistance rating* constructed in accordance with Section 708 and floor assemblies with a 1-hour but less than 2-hour *fire-resistance rating* constructed in accordance with Section 711, or with only one tenant within the floor area.
4. Category d—*Fire barriers* with a 1-hour but less than 2-hour *fire-resistance rating* constructed in accordance with Section 707 and floor assemblies with a 2-hour or greater *fire-resistance rating* constructed in accordance with Section 711.

EXISTING BUILDINGS AND STRUCTURES

- 5. Category e—*Fire barriers* and floor assemblies with a 2-hour or greater *fire-resistance rating* and constructed in accordance with Sections 707 and 711, respectively.

3412.6.5 Corridor walls. Evaluate the *fire-resistance rating* and degree of completeness of walls which create *corridors* serving the floor, and constructed in accordance with Section 1020. This evaluation shall not include the wall elements considered under Sections 3412.6.3 and 3412.6.4. Under the categories and groups in Table 3412.6.5, determine the appropriate value and enter that value into Table 3412.7 under Safety Parameter 3412.6.5, Corridor Walls, for fire safety, means of egress and general safety.

**TABLE 3412.6.5
CORRIDOR WALL VALUES**

OCCUPANCY	CATEGORIES			
	a	b	c ^a	d ^a
A-1	-10	-4	0	2
A-2	-30	-12	0	2
A-3, F, M, R, S-1	-7	-3	0	2
A-4, B, E, S-2	-5	-2	0	5

a. Corridors not providing at least one-half the travel distance for all occupants on a floor shall be category b.

3412.6.5.1 Categories. The categories for Corridor Walls are:

1. Category a—No *fire partitions*; incomplete *fire partitions*; no doors; or doors not self-closing.
2. Category b—Less than 1-hour *fire-resistance rating* or not constructed in accordance with Section 708.4.
3. Category c—1-hour to less than 2-hour *fire-resistance rating*, with doors conforming to Section 716 or without *corridors* as permitted by Section 1020.
4. Category d—2-hour or greater *fire-resistance rating*, with doors conforming to Section 716.

3412.6.6 Vertical openings. Evaluate the *fire-resistance rating* of *exit* enclosures, hoistways, escalator openings and other shaft enclosures within the building, and openings between two or more floors. Table 3412.6.6(1) contains the appropriate protection values. Multiply that value

by the construction type factor found in Table 3412.6.6(2). Enter the vertical opening value and its sign (positive or negative) in Table 3412.7 under Safety Parameter 3412.6.6, Vertical Openings, for fire safety, means of egress, and general safety. If the structure is a one-story building or if all the unenclosed vertical openings within the building conform to the requirements of Section 712, enter a value of 2. The maximum positive value for this requirement shall be 2.

**TABLE 3412.6.6(1)
VERTICAL OPENING PROTECTION VALUE**

PROTECTION	VALUE
None (unprotected opening)	-2 times number floors connected
Less than 1 hour	-1 times number floors connected
1 to less than 2 hours	1
2 hours or more	2

**TABLE 3412.6.6(2)
CONSTRUCTION-TYPE FACTOR**

CONSTRUCTION TYPE FACTOR	TYPE OF CONSTRUCTION								
	IA	IB	IIA	IIB	IIIA	IIIB	IV	VA	VB
	1.2	1.5	2.2	3.5	2.5	3.5	2.3	3.3	7

3412.6.6.1 Vertical opening formula. The following formula shall be used in computing vertical opening value.

$$VO = PV \times CF \quad \text{(Equation 34-5)}$$

where:

VO = Vertical opening value.

PV = Protection value [Table 3412.6.6(1)].

CF = Construction type factor [Table 3412.6.6(2)].

3412.6.7 HVAC systems. Evaluate the ability of the HVAC system to resist the movement of smoke and fire beyond the point of origin. Under the categories in Section 3412.6.7.1, determine the appropriate value and enter that value into Table 3412.7 under Safety Parameter 3412.6.7, HVAC Systems, for fire safety, means of egress and general safety.

**TABLE 3412.6.3
COMPARTMENTATION VALUES**

OCCUPANCY	CATEGORIES ^a				
	a Compartment size equal to or greater than 15,000 square feet	b Compartment size of 10,000 square feet	c Compartment size of 7,500 square feet	d Compartment size of 5,000 square feet	e Compartment size of 2,500 square feet or less
A-1, A-3	0	6	10	14	18
A-2	0	4	10	14	18
A-4, B, E, S-2	0	5	10	15	20
F, M, R, S-1	0	4	10	16	22

For SI: 1 square foot = 0.093 m².

a. For areas between categories, the compartmentation value shall be obtained by linear interpolation.

3412.6.7.1 Categories. The categories for HVAC systems are:

1. Category a—Plenums not in accordance with Section 602 of the *International Mechanical Code*. -10 points.
2. Category b—Air movement in egress elements not in accordance with Section 1020.5. -5 points.
3. Category c—Both categories a and b are applicable. -15 points.
4. Category d—Compliance of the HVAC system with Section 1018.5 and Section 602 of the *International Mechanical Code*. 0 points.
5. Category e—Systems serving one *story*; or a central boiler/chiller system without ductwork connecting two or more stories. 5 points.

3412.6.8 Automatic fire detection. Evaluate the smoke detection capability based on the location and operation of *automatic fire detectors* in accordance with Section 907 and the *International Mechanical Code*. Under the categories and occupancies in Table 3412.6.8, determine the appropriate value and enter that value into Table 3412.7 under Safety Parameter 3412.6.8, Automatic Fire Detection, for fire safety, means of egress and general safety.

**TABLE 3412.6.8
AUTOMATIC FIRE DETECTION VALUES**

OCCUPANCY	CATEGORIES				
	a	b	c	d	e
A-1, A-3, F, M, R, S-1	-10	-5	0	2	6
A-2	-25	-5	0	5	9
A-4, B, E, S-2	-4	-2	0	5	8

3412.6.8.1 Categories. The categories for automatic fire detection are:

1. Category a—None.
2. Category b—Existing *smoke detectors* in HVAC systems and maintained in accordance with the *International Fire Code*.
3. Category c—*Smoke detectors* in HVAC systems. The detectors are installed in accordance with the requirements for new buildings in the *International Mechanical Code*.
4. Category d—*Smoke detectors* throughout all floor areas other than individual *sleeping units*, tenant spaces and *dwelling units*.
5. Category e—*Smoke detectors* installed throughout the floor area.

3412.6.9 Fire alarm systems. Evaluate the capability of the *fire alarm system* in accordance with Section 907. Under the categories and occupancies in Table 3412.6.9, determine the appropriate value and enter that value into

Table 3412.7 under Safety Parameter 3412.6.9, Fire Alarm Systems, for fire safety, means of egress and general safety.

**TABLE 3412.6.9
FIRE ALARM SYSTEM VALUES**

OCCUPANCY	CATEGORIES			
	a	b ^a	c	d
A-1, A-2, A-3, A-4, B, E, R	-10	-5	0	5
F, M, S	0	5	10	15

a. For buildings equipped throughout with an *automatic sprinkler system*, add 2 points for activation by a sprinkler waterflow device.

3412.6.9.1 Categories. The categories for *fire alarm systems* are:

1. Category a—None.
2. Category b—*Fire alarm system* with *manual fire alarm boxes* in accordance with Section 907.4 and alarm notification appliances in accordance with Section 907.5.2.
3. Category c—*Fire alarm system* in accordance with Section 907.
4. Category d—Category c plus a required *emergency voice/alarm communications* system and a *fire command center* that conforms to Section 403.4.6 and contains the *emergency voice/alarm communications* system controls, fire department communication system controls and any other controls specified in Section 911 where those systems are provided.

3412.6.10 Smoke control. Evaluate the ability of a natural or mechanical venting, exhaust or pressurization system to control the movement of smoke from a fire. Under the categories and occupancies in Table 3412.6.10, determine the appropriate value and enter that value into Table 3412.7 under Safety Parameter 3412.6.10, Smoke Control, for means of egress and general safety.

**TABLE 3412.6.10
SMOKE CONTROL VALUES**

OCCUPANCY	CATEGORIES					
	a	b	c	d	e	f
A-1, A-2, A-3	0	1	2	3	6	6
A-4, E	0	0	0	1	3	5
B, M, R	0	2 ^a	3 ^a	3 ^a	3 ^a	4 ^a
F, S	0	2 ^a	2 ^a	3 ^a	3 ^a	3 ^a

a. This value shall be 0 if compliance with Category d or e in Section 3412.6.8.1 has not been obtained.

3412.6.10.1 Categories. The categories for smoke control are:

1. Category a—None.
2. Category b—The building is equipped throughout with an *automatic sprinkler system*. Openings are provided in exterior walls at the rate of 20 square feet (1.86 m²) per 50 linear feet (15 240

mm) of exterior wall in each story and distributed around the building perimeter at intervals not exceeding 50 feet (15 240 mm). Such openings shall be readily openable from the inside without a key or separate tool and shall be provided with ready access thereto. In lieu of operable openings, clearly and permanently marked tempered glass panels shall be used.

3. Category c—One enclosed exit stairway, with ready access thereto, from each occupied floor of the building. The stairway has operable exterior windows and the building has openings in accordance with Category b.
4. Category d—One smokeproof enclosure and the building has openings in accordance with Category b.
5. Category e—The building is equipped throughout with an automatic sprinkler system. Each floor area is provided with a mechanical air-handling system designed to accomplish smoke containment. Return and exhaust air shall be moved directly to the outside without recirculation to other floor areas of the building under fire conditions. The system shall exhaust not less than six air changes per hour from the floor area. Supply air by mechanical means to the floor area is not required. Containment of smoke shall be considered as confining smoke to the floor area involved without migration to other floor areas. Any other tested and approved design which will adequately accomplish smoke containment is permitted.
6. Category f—Each stairway shall be one of the following: a smokeproof enclosure in accordance with Section 1023.11; pressurized in accordance with Section 909.20.5 or shall have operable exterior windows.

3412.6.11 Means of egress capacity and number. Evaluate the means of egress capacity and the number of exits available to the building occupants. In applying this section, the means of egress are required to conform to the following sections of this code: 1003.7, 1004, 1005, 1006, 1007, 1016.2, 1017.2, 1026.1, 1029.2, 1028.5, 1029.2, 1029.3, 1029.4 and 1030. The number of exits credited is the number that is available to each occupant of the area being evaluated. Existing fire escapes shall be accepted as a component in the means of egress when conforming to Section 3406.

Under the categories and occupancies in Table 3412.6.11, determine the appropriate value and enter that value into Table 3412.7 under Safety Parameter 3412.6.11, Means of Egress Capacity, for means of egress and general safety.

**TABLE 3412.6.11
MEANS OF EGRESS VALUES**

OCCUPANCY	CATEGORIES				
	a ^a	b	c	d	e
A-1, A-2, A-3, A-4, E	-10	0	2	8	10
M	-3	0	1	2	4
B, F, S	-1	0	0	0	0
R	-3	0	0	0	0

a. The values indicated are for buildings six stories or less in height. For buildings over six stories above grade plane, add an additional -10 points.

3412.6.11.1 Categories. The categories for Means of Egress Capacity and number of exits are:

1. Category a—Compliance with the minimum required means of egress capacity or number of exits is achieved through the use of a fire escape in accordance with Section 3406.
2. Category b—Capacity of the means of egress complies with Section 1004 and the number of exits complies with the minimum number required by Section 1006.
3. Category c—Capacity of the means of egress is equal to or exceeds 125 percent of the required means of egress capacity, the means of egress complies with the minimum required width dimensions specified in the code and the number of exits complies with the minimum number required by Section 1006.
4. Category d—The number of exits provided exceeds the number of exits required by Section 1006. Exits shall be located a distance apart from each other equal to not less than that specified in Section 1006.
5. Category e—The area being evaluated meets both Categories c and d.

3412.6.12 Dead ends. In spaces required to be served by more than one means of egress, evaluate the length of the exit access travel path in which the building occupants are confined to a single path of travel. Under the categories and occupancies in Table 3412.6.12, determine the appropriate value and enter that value into Table 3412.7 under Safety Parameter 3412.6.12, Dead Ends, for means of egress and general safety.

**TABLE 3412.6.12
DEAD-END VALUES**

OCCUPANCY	CATEGORIES ^a		
	a	b	c
A-1, A-3, A-4, B, E, F, M, R, S	-2	0	2
A-2, E	-2	0	2

a. For dead-end distances between categories, the dead-end value shall be obtained by linear interpolation.

3412.6.12.1 Categories. The categories for dead ends are:

1. Category a—Dead end of 35 feet (10 670 mm) in nonsprinklered buildings or 70 feet (21 340 mm) in sprinklered buildings.
2. Category b—Dead end of 20 feet (6096 mm); or 50 feet (15 240 mm) in Group B in accordance with Section 1020.4, exception 2.
3. Category c—No dead ends; or ratio of length to width (l/w) is less than 2.5:1.

3412.6.13 Maximum exit access travel distance. Evaluate the length of *exit access* travel to an *approved exit*. Determine the appropriate points in accordance with the following equation and enter that value into Table 3412.7 under Safety Parameter 3412.6.13, Maximum Exit Access Travel Distance, for means of egress and general safety. The maximum allowable *exit access* travel distance shall be determined in accordance with Section 1017.1.

$$\text{Points} = 20 \times \frac{\text{Maximum allowable travel distance} - \text{Maximum actual travel distance}}{\text{Max. allowable travel distance}}$$

(Equation 34-6)

3412.6.14 Elevator control. Evaluate the passenger elevator equipment and controls that are available to the fire department to reach all occupied floors. Emergency recall and in-car operation of elevator recall controls shall be provided in accordance with the *International Fire Code*. Under the categories and occupancies in Table 3412.6.14, determine the appropriate value and enter that value into Table 3412.7 under Safety Parameter 3412.6.14, Elevator Control, for fire safety, means of egress and general safety. The values shall be zero for a single-story building.

3412.6.14.1 Categories. The categories for elevator controls are:

1. Category a—No elevator.
2. Category b—Any elevator without Phase I emergency recall operation and Phase II emergency in-car operation.
3. Category c—All elevators with Phase I emergency recall operation and Phase II emergency in-car operation as required by the *International Fire Code*.

4. Category d—All meet Category c; or Category b where permitted to be without Phase I emergency recall operation and Phase II emergency in-car operation; and at least one elevator that complies with new construction requirements serves all occupied floors.

3412.6.15 Means of egress emergency lighting. Evaluate the presence of and reliability of *means of egress* emergency lighting. Under the categories and occupancies in Table 3412.6.15, determine the appropriate value and enter that value into Table 3412.7 under Safety Parameter 3412.6.15, Means of Egress Emergency Lighting, for means of egress and general safety.

TABLE 3412.6.15
MEANS OF EGRESS EMERGENCY LIGHTING VALUES

NUMBER OF EXITS REQUIRED BY SECTION 1007	CATEGORIES		
	a	b	c
Two or more exits	NP	0	4
Minimum of one exit	0	1	1

3412.6.15.1 Categories. The categories for means of egress emergency lighting are:

1. Category a—*Means of egress* lighting and *exit* signs not provided with emergency power in accordance with Chapter 27.
2. Category b—*Means of egress* lighting and *exit* signs provided with emergency power in accordance with Chapter 27.
3. Category c—Emergency power provided to *means of egress* lighting and *exit* signs which provides protection in the event of power failure to the site or building.

3412.6.16 Mixed occupancies. Where a building has two or more occupancies that are not in the same occupancy classification, the separation between the mixed occupancies shall be evaluated in accordance with this section. Where there is no separation between the mixed occupancies or the separation between mixed occupancies does not qualify for any of the categories indicated in Section 3412.6.16.1, the building shall be evaluated as indicated in Section 3412.6 and the value for mixed occupancies shall be zero. Under the categories and occupancies in Table 3412.6.16, determine the appropriate value and enter that value into Table 3412.7 under Safety Parameter 3412.6.16, Mixed Occupancies, for fire safety and general safety. For buildings without mixed occupancies, the value shall be zero.

TABLE 3412.6.14
ELEVATOR CONTROL VALUES

ELEVATOR TRAVEL	CATEGORIES			
	a	b	c	d
Less than 25 feet of travel above or below the primary level of elevator access for emergency fire-fighting or rescue personnel	-2	0	0	+2
Travel of 25 feet or more above or below the primary level of elevator access for emergency fire-fighting or rescue personnel	-4	NP	0	+4

For SI: 1 foot = 304.8 mm.
NP = Not permitted

**TABLE 3412.6.16
MIXED OCCUPANCY VALUES^a**

OCCUPANCY	CATEGORIES		
	a	b	c
A-1, A-2, R	-10	0	10
A-3, A-4, B, E, F, M, S	-5	0	5

a. For fire-resistance ratings between categories, the value shall be obtained by linear interpolation.

3412.6.16.1 Categories. The categories for mixed occupancies are:

1. Category a—Occupancies separated by minimum 1-hour *fire barriers* or minimum 1-hour *horizontal assemblies*, or both.
2. Category b—Separations between occupancies in accordance with Section 508.4.
3. Category c—Separations between occupancies having a *fire-resistance rating* of not less than twice that required by Section 508.4.4.

3412.6.17 Automatic sprinklers. Evaluate the ability to suppress a fire based on the installation of an *automatic sprinkler system* in accordance with Section 903.3.1.1. “Required sprinklers” shall be based on the requirements of this code. Under the categories and occupancies in Table 3412.6.17, determine the appropriate value and enter that value into Table 3412.7 under Safety Parameter 3412.6.17, Automatic Sprinklers, for fire safety, means of egress divided by 2 and general safety.

**TABLE 3412.6.17
SPRINKLER SYSTEM VALUES**

OCCUPANCY	CATEGORIES					
	a	b	c	d	e	f
A-1, A-3, F, M, R, S-1	-6	3	2	2	4	6
A-2	-4	0	1	2	4	4
A-4, B, E, S-2	-12	-6	0	3	6	12

3412.6.17.1 Categories. The categories for *automatic sprinkler system* protection are:

1. Category a—Sprinklers are required throughout; sprinkler protection is not provided or the sprinkler system design is not adequate for the hazard protected in accordance with Section 903.
2. Category b—Sprinklers are required in a portion of the building; sprinkler protection is not provided or the sprinkler system design is not adequate for the hazard protected in accordance with Section 903.
3. Category c—Sprinklers are not required; none are provided.
4. Category d—Sprinklers are required in a portion of the building; sprinklers are provided in such portion; the system is one which complied with the code at the time of installation and is main-

tained and supervised in accordance with Section 903.

5. Category e—Sprinklers are required throughout; sprinklers are provided throughout in accordance with Chapter 9.
6. Category f—Sprinklers are not required throughout; sprinklers are provided throughout in accordance with Chapter 9.

3412.6.18 Standpipes. Evaluate the ability to initiate attack on a fire by making a supply of water available readily through the installation of standpipes in accordance with Section 905. Required standpipes shall be based on the requirements of this code. Under the categories and occupancies in Table 3412.6.18, determine the appropriate value and enter that value into Table 3412.7 under Safety Parameter 3412.6.18, Standpipes, for fire safety, means of egress and general safety.

**TABLE 3412.6.18
STANDPIPE SYSTEM VALUES**

OCCUPANCY	CATEGORIES			
	a ^a	b	c	d
A-1, A-3, F, M, R, S-1	-6	0	4	6
A-2	-4	0	2	4
A-4, B, E, S-2	-12	0	6	12

This option cannot be taken if Category a or b in Section 3412.6.17 is

3412.6.18.1 Standpipe. The categories for standpipe systems are:

1. Category a—Standpipes are required; standpipe is not provided or the standpipe system design is not in compliance with Section 905.3.
2. Category b—Standpipes are not required; none are provided.
3. Category c—Standpipes are required; standpipes are provided in accordance with Section 905.
4. Category d—Standpipes are not required; standpipes are provided in accordance with Section 905.

3412.6.19 Incidental uses. Evaluate the protection of incidental uses in accordance with Section 509.4.2. Do not include those where this code requires automatic sprinkler systems throughout the buildings, including *covered or open mall buildings, high-rise buildings*, public garages and unlimited area buildings. Assign the lowest score from Table 3412.6.19 for the building or floor area being evaluated and enter that value into Table 3412.7 under safety Parameter 3412.6.19, Incidental Use Area, for fire safety, means of egress and general safety. If there are no specific occupancy areas in the building or floor area being evaluated, the value shall be zero.

3412.7 Building score. After determining the appropriate data from Section 3412.6, enter those data in Table 3412.7 and total the building score.

3412.8 Safety scores. The values in Table 3412.8 are the required mandatory safety scores for the evaluation process listed in Section 3412.6.

3412.9 Evaluation of building safety. The mandatory safety score in Table 3412.8 shall be subtracted from the building score in Table 3412.7 for each category. Where the final score for any category equals zero or more, the building is in compliance with the requirements of this section for that category. Where the final score for any category is less than zero, the building is not in compliance with the requirements of this section.

3412.9.1 Mixed occupancies. For mixed occupancies, the following provisions shall apply:

1. Where the separation between mixed occupancies does not qualify for any category indicated in Section 3412.6.16, the mandatory safety scores for the occupancy with the lowest general safety score in Table 3412.8 shall be utilized (see Section 3412.6).
2. Where the separation between mixed occupancies qualifies for any category indicated in Section 3412.6.16, the mandatory safety scores for each occupancy shall be placed against the evaluation scores for the appropriate occupancy.

**TABLE 3412.6.9
INCIDENTAL USE AREA VALUES**

PROTECTION REQUIRED BY TABLE 509	PROTECTION PROVIDED						
	None	1 Hour	AS	AS with SP	1 Hour and AS	2 Hours	2 Hours and AS
2 Hours and AS	-4	-3	-2	-2	-1	-2	0
2 Hours, or 1 Hour and AS	-3	-2	-1	-1	0	0	0
1 Hour and AS	-3	-2	-1	-1	0	-1	0
1 Hour	-1	0	-1	0	0	0	0
1 Hour, or AS with SP	-1	0	-1	0	0	0	0
AS with SP	-1	-1	-1	0	0	-1	0
1 Hour or AS	-1	0	0	0	0	0	0

AS = Automatic sprinkler system; SP = Smoke partitions (See Section 509.4.2).

Note: For Table 3412.7, see next page.

EXISTING BUILDINGS AND STRUCTURES

TABLE 3412.7
SUMMARY SHEET—BUILDING CODE

Existing occupancy: _____ Proposed occupancy: _____

Year building was constructed: _____ Number of stories: _____ Height in feet: _____

Type of construction: _____ Area per floor: _____

Percentage of open perimeter increase: _____%

Completely suppressed: Yes ___ No ___ Corridor wall rating: _____

Compartmentation: Yes ___ No ___ Required door closers: Yes ___ No ___

Fire-resistance rating of vertical opening enclosures: _____

Type of HVAC system: _____, serving number of floors: _____

Automatic fire detection: Yes ___ No ___ Type and location: _____

Fire alarm system: Yes ___ No ___ Type: _____

Smoke control: Yes ___ No ___ Type: _____

Adequate exit routes: Yes ___ No ___ Dead ends: _____ Yes ___ No ___

Maximum exit access travel distance: _____ Elevator controls: Yes ___ No ___

Means of egress emergency lighting: Yes ___ No ___ Mixed occupancies: Yes ___ No ___

SAFETY PARAMETERS	FIRE SAFETY (FS)	MEANS OF EGRESS (ME)	GENERAL SAFETY (GS)
3412.6.1 Building Height			
3412.6.2 Building Area			
3412.6.3 Compartmentation			
3412.6.4 Tenant and Dwelling Unit Separations 3412.6.5 Corridor Walls			
3412.6.6 Vertical Openings			
3412.6.7 HVAC Systems			
3412.6.8 Automatic Fire Detection			
3412.6.9 Fire Alarm Systems			
3412.6.10 Smoke Control	***		
3412.6.11 Means of Egress Capacity	***		
3412.6.12 Dead Ends	***		
3412.6.13 Maximum Exit Access Travel Distance	***		
3412.6.14 Elevator Control	***		
3412.6.15 Means of Egress Emergency Lighting	***		
3412.6.16 Mixed Occupancies		***	
3412.6.17 Automatic Sprinklers		÷ 2 =	
3412.6.18 Standpipes			
3412.6.19 Incidental Use			
Building score — total value			

***No applicable value to be inserted.

**TABLE 3412.8
MANDATORY SAFETY SCORES^a**

OCCUPANCY	FIRE SAFETY (MFS)	MEANS OF EGRESS (MME)	GENERAL SAFETY (MGS)
A-1	20	31	31
A-2	21	32	32
A-3	22	33	33
A-4, E	29	40	40
B	30	40	40
F	24	34	34
M	23	40	40
R	21	38	38
S-1	19	29	29
S-2	29	39	39

- a. MFS = Mandatory Fire Safety;
MME = Mandatory Means of Egress;
MGS = Mandatory General Safety.

**TABLE 3412.9
EVALUATION FORMULAS^a**

FORMULA	T.3412.7		T.3412.8	SCORE	PASS	FAIL
FS-MFS ≥ 0	_____	(FS)	_____ (MFS) =	_____	_____	_____
ME-MME ≥ 0	_____	(ME)	_____ (MME) =	_____	_____	_____
GS-MGS ≥ 0	_____	(GS)	_____ (MGS) =	_____	_____	_____

- a. FS = Fire Safety
ME = Means of Egress
GS = General Safety
MFS = Mandatory Fire Safety
MME = Mandatory Means of Egress
MGS = Mandatory General Safety

PROPOSED

PROPOSED



Georgia State Amendments to the International Residential Code for One- and Two- Family Dwellings (2018 Edition)



Georgia Department of Community Affairs
Community Development Division
60 Executive Park South, N.E.
Atlanta, Georgia 30329-2231
(404) 679-3118
www.dca.ga.gov

Revised January 1, 2020

**GEORGIA STATE MINIMUM STANDARD
ONE AND TWO FAMILY DWELLING CODE
(INTERNATIONAL RESIDENTIAL CODE FOR
ONE- AND TWO-FAMILY DWELLINGS
WITH GEORGIA STATE AMENDMENTS)**

The **INTERNATIONAL RESIDENTIAL CODE FOR ONE- AND TWO-FAMILY DWELLINGS, 2018 Edition**, published by the International Code Council, when used in conjunction with these and any other Georgia State Amendments to the **INTERNATIONAL RESIDENTIAL CODE FOR ONE- AND TWO-FAMILY DWELLINGS, 2018 Edition**, shall constitute the official *Georgia State Minimum Standard One- and Two-Family Dwelling Code*.

Part IV, Energy Conservation (Chapter 11), is deleted from the **INTERNATIONAL RESIDENTIAL CODE FOR ONE- AND TWO-FAMILY DWELLINGS**. Substitute all references to Chapter 11 **ENERGY EFFICIENCY** with references to the *Georgia State Minimum Standard Energy Code (International Energy Conservation Code with Georgia State Supplements and Amendments)*.

Part VII, Plumbing (Chapters 25 through 33), is deleted from the **INTERNATIONAL RESIDENTIAL CODE FOR ONE- AND TWO-FAMILY DWELLINGS**. Substitute for plumbing requirements the *Georgia State Minimum Standard Plumbing Code (International Plumbing Code with Georgia State Amendments)*.

Part VIII, Electrical (Chapters 34 through 43), is deleted from the **INTERNATIONAL RESIDENTIAL CODE FOR ONE- AND TWO-FAMILY DWELLINGS**. Substitute for electrical requirements the *Georgia State Minimum Standard Electrical Code (National Electrical Code with any Georgia State Amendments)*.

GEORGIA STATE AMENDMENTS

CODE REFERENCES:

- (a) Replace all references to the ICC *Electrical Code* with references to the *Georgia State Minimum Standard Electrical Code (National Electrical Code with any Georgia State Amendments)*.
- (b) Replace all references to the *International Energy Conservation Code (IECC)* with references to the *Georgia State Minimum Standard Energy Code (IECC with Georgia State Supplements and Amendments)*. The *Georgia State Minimum Standard Energy Code* shall be used for heating and air conditioning equipment.

SCOPE:

The provisions of the *International Residential Code for One- and Two-family Dwellings* shall apply to the construction, *alteration*, movement, enlargement, replacement, repair, equipment, use and occupancy, location, removal and demolition of detached one- and two-family dwellings and townhouses separated by a 2-hour fire-resistance-rated wall assembly, not more than three stories above *grade plane* in height with a separate means of egress and their *accessory structures*.

Exceptions:

1. Live/work units complying with the requirements of Section 419 of the *International Building Code* shall be permitted to be built as one- and two-family *dwellings* or townhouses. Fire suppression required by Section 419.5 of the *International Building Code* when constructed under the *International Residential Code for One- and Two-family Dwellings* shall conform to NFPA 13D.
2. Owner-occupied lodging houses with five or fewer guestrooms shall be permitted to be constructed in accordance with the *International Residential Code for One- and Two-family Dwellings* when equipped with a fire sprinkler system in accordance with NFPA 13D.

IMPORTANT NOTE:

The intent of the GA amendments is that fire sprinklers shall not be mandatory in one- and two-family dwellings. However, the provisions of the 2018 Edition of the *International Residential Code for One- and Two-Family Dwellings* regarding automatic fire sprinklers are to remain in the Code for use when the builder/developer or owner chooses to install fire sprinklers as an option.

{Ref. O.C.G.A. §8-2-4. Neither the state residential and fire building code nor any residential and fire building code adopted by a political subdivision of the state adopted after May 24, 2010, shall include a requirement that fire sprinklers be installed in a single-family dwelling or a residential building that contains no more than two dwelling units. }

APPENDICES:

Appendices are not enforceable unless they are specifically referenced in the body of the code or adopted by the Department of Community Affairs or the Authority Having Jurisdiction.

****Revise the International Residential Code for One- and Two-Family Dwellings, 2018 Edition, as follows:***

CHAPTER 1 SCOPE AND ADMINISTRATION

****Delete Chapter 1 ‘Scope and Administration’ without substitution. Chapter 1 to remain in the Code as a reference and guide for local governments to use in development of their own Administrative Procedures.
(Effective January 1, 2020)***

CHAPTER 2 DEFINITIONS

SECTION R202 DEFINITIONS

*Revise Section R202 ‘Definitions’ for “[RB] Lodging House” to read as follows:

[RB] LODGING HOUSE. A one-family dwelling with 5 or fewer guestrooms, where one or more occupants are primarily permanent in nature, and rent is paid for guestrooms.
(Effective January 1, 2020)

*Revise Section R202 ‘Definitions’ for “[RB] Townhouse” to read as follows:

[RB] TOWNHOUSE (ROW HOUSE). A single-family *dwelling unit* constructed in a group of three or more attached units. Each unit extends from foundation to roof, not more than three stories in height, with a separate means of egress, and with an open space/*yard* or public way on at least two sides. Each townhouse shall be considered a separate building with independent exterior walls and shall be separated by a 2-hour fire-resistance-rated wall assembly.
(Effective January 1, 2020)

CHAPTER 3 BUILDING PLANNING

SECTION R302 FIRE-RESISTANT CONSTRUCTION

*Revise Section R302.1 ‘Exterior walls’ to read as follows:

R302.1 Exterior walls. Construction, projections, openings and penetrations of *exterior walls* of *dwelling*s and accessory buildings shall comply with Table R302.1(1); or *dwelling*s equipped throughout with an *automatic sprinkler system* installed in accordance with NFPA 13D shall comply with Table R302.1(2).
(Existing exceptions to remain as written).
(Effective January 1, 2020)

*Revise Section R302.2 ‘Townhouses’ to read as follows:

R302.2 Townhouses. Each *townhouse* shall be considered a separate building and shall be separated by fire-resistance-rated wall assemblies meeting the requirements of Section R302.1 for exterior walls.

Exception: A common 2-hour fire-resistance-rated wall assembly tested in accordance with ASTM E 119 or UL 263 is permitted for townhouses, if such walls do not contain plumbing or mechanical equipment, ducts or vents in the cavity of the common wall. The wall shall be rated for fire exposure from both sides and shall extend to and be tight against exterior walls and the underside of the roof sheathing. Electrical installations shall be installed in accordance with the National Electrical Code (NEC). Penetrations of electrical outlet boxes shall be in accordance with Section R302.4.
(Effective January 1, 2020)

* Delete Section R302.2.1 ‘Double walls’ without substitution.
(Effective January 1, 2020)

* Delete Section R302.2.2 ‘Common walls’ without substitution.
(Effective January 1, 2020)

*Revise Section R302.2.6 ‘Structural independence’ to delete exception #5 without substitution.
(Effective January 1, 2020)

*Revise Section R302.5.1 ‘Opening protection’ to read as follows:

R302.5.1 Opening protection. Openings from a private garage directly into a room used for sleeping purposes shall not be permitted. Other openings between the garage and residence shall be equipped with solid wood doors not less than 1 3/8 inches (35 mm) in thickness, solid or honey-comb-core steel doors not less than 1 3/8 inches (35 mm) thick, or 20-minute fire rated doors.
(Effective January 1, 2020)

*Revise Table R302.6 ‘DWELLING-GARAGE SEPARATION’ to add a new footnote “a” to read as follows:

**TABLE R302.6
DWELLING-GARAGE SEPARATION**

SEPARATION	MATERIAL
From the residence and attics	Not less than 1/2-inch gypsum board or equivalent applied to the garage side
From all habitable rooms above the garage	Not less than 5/8-inch Type X gypsum board or equivalent
Structure(s) supporting floor/ceiling assemblies used for separation required by this section ^a	Not less than 1/2-inch gypsum board or equivalent
Garages located less than 3 feet from a dwelling unit on the same lot	Not less than 1/2-inch gypsum board or equivalent applied to the interior side of exterior walls that are within this area

For SI: 1 inch = 25.4 mm, 1 foot = 304.8 mm.

a. Separation of floor/ceiling assemblies is not required in garages protected by an automatic sprinkler system that meets the following criteria:

1. The sprinkler system shall be connected to a reliable water supply system with or without an automatic operated pump.
2. A piping system serving both sprinkler and domestic needs shall be acceptable.
3. Ordinary-temperature-rated residential or quick response sprinklers (135°F to 170°F [57°C to 77°C]) with a 1/2-inch (13 mm) orifice shall be installed.
4. The minimum operating pressure of any residential or quick response sprinkler shall be 7 psi (0.5 bar).
5. Walls that resist the passage of smoke shall separate the sprinklered compartment from any other space(s). Openings in this wall shall be regulated by Section R302.5.
6. The maximum area protected by a single sprinkler head shall not exceed 144 ft² (13.4 m²).
7. The maximum distance between sprinklers shall not exceed 12 feet (3.7 m).
8. The maximum distance to a wall or partition shall not exceed 6 feet (1.8 m).
9. The minimum distance between sprinklers within a compartment shall be 8 feet (2.4 m).
10. Pendent and upright sprinkler heads shall be positioned so that the deflectors are within 1 to 4 inches (25.4 to 102 mm) below framing.
11. Sprinkler heads shall be located on a looped piping configuration.
12. Minimum pipe size, including that for copper, listed chlorinated polyvinyl chloride (CPVC), and polybutylene (PB) piping shall be 3/4-inch (19 mm).
13. Garage doors in the open position shall not interfere with the operation of a sprinkler head.
14. A smoke alarm detector shall be installed in accordance with Section R314.

(Effective January 1, 2020)

*Delete Section R302.13 ‘Fire protection of floors’ without substitution.
(Effective January 1, 2020)

**SECTION R303
LIGHT, VENTILATION AND HEATING**

*Revise Section R303.4 ‘Mechanical ventilation’ to read as follows:

R303.4 Mechanical ventilation. Where the air infiltration rate of a *dwelling unit* is 3 air changes per hour or less where tested with a blower door at a pressure of 0.2 inch w.c (50 Pa) in accordance with Section N1102.4.1.2, the *dwelling unit* shall be provided with whole-house mechanical ventilation in accordance with Section M1505.4.
(Effective January 1, 2020)

**SECTION R306
SANITATION**

*Add new Section R306.5 ‘Exterior hose bibs, sill cocks or outside hydrants’ to read as follows:

R306.5 Exterior hose bibs, sill cocks or outside hydrants. One and two-family dwellings shall have not less than two exterior hose bibs, sill cocks or outside hydrants with one being located on the side or rear of the structure.
(Effective January 1, 2020)

*Add new Section R306.6 ‘Construction worker toilet facilities’ to read as follows:

R306.6 Construction worker toilet facilities. Toilet facilities shall be provided for construction workers and such facilities shall be maintained in a sanitary condition. Construction worker toilet facilities of the non-sewer type shall conform to ANSI Z4.3.
(Effective January 1, 2020)

**SECTION R309
GARAGES AND CARPORTS**

*Delete Section R309.5 ‘Fire sprinklers’ without substitution.
(Effective January 1, 2020)

**SECTION R311
MEANS OF EGRESS**

*Delete Exception to Section R311.7.11 ‘Alternating tread devices’ without substitution.
(Effective January 1, 2020)

**SECTION R312
GUARDS AND WINDOW FALL PROTECTION**

*Revise the heading of Section R312 ‘Guards and Window Fall Protection’ to read as follows:

**SECTION R312
GUARDS
(Effective January 1, 2020)**

*Delete Section R312.2 ‘Window fall protection’ without substitution.
(Effective January 1, 2020)

**SECTION R313
AUTOMATIC FIRE SPRINKLER SYSTEMS**

*Delete Section R313 ‘AUTOMATIC FIRE SPRINKLER SYSTEMS’ and substitute to read as follows:

**SECTION R313
AUTOMATIC FIRE SPRINKLER SYSTEMS
(Optional)**

R313.1 Automatic fire sprinkler systems (Optional). Installation of an automatic residential fire sprinkler system shall be optional and not mandatory in one- and two-family *dwelling*s and *townhouses*.
(Effective January 1, 2020)

R313.2 Design and installation. When installed, automatic residential fire sprinkler systems for one- and two-family *dwelling*s and *townhouses* shall be designed and installed in accordance with NFPA 13D.
(Effective January 1, 2020)

*Delete any other code references to Section P2904 ‘Dwelling unit fire sprinkler systems’ and substitute NFPA 13D.
(Effective January 1, 2020)

**SECTION R315
CARBON MONOXIDE ALARMS**

* Revise Section R315.2.1 ‘New Construction’ to read as follows:

R315.2.1 New construction. For new construction, carbon monoxide alarms shall be provided in dwelling units.
(Effective January 1, 2020)

**SECTION R321
ELEVATORS AND PLATFORM LIFTS**

*Revise Section R321.1 ‘Elevators’ and add a new Section R321.1.1 ‘Hoistway opening framing’ to read as follows:

R321.1 Elevators. Where provided, limited-use and limited-application elevators or private residence elevators shall comply with ASME A17.1/CSA B44.
(Effective January 1, 2020)

R321.1.1 Hoistway opening framing. Limited-use/limited-application elevators or private residence elevators shall have hoistway landing openings that meet the Georgia amended requirements of ASME A17.1/CSA B44 Sections 5.3.1.1 and 5.3.1.7.2. The clearance between the hoistway doors or gates and the hoistway edge of the landing sill shall not exceed 3/4 inch (19 mm). The distance between the hoistway face of the landing door or gate and the car door or gate shall not exceed 3 inches (75 mm).
(Effective January 1, 2020)

**SECTION R322
FLOOD-RESISTANT CONSTRUCTION**

*Delete Section R322.1.9 ‘Manufactured homes’ without substitution.
(Effective January 1, 2020)

**CHAPTER 5
FLOORS**

**SECTION R502
WOOD FLOOR FRAMING**

* Revise Section R502.6 ‘Bearing’ to read as follows:

R502.6 Bearing. The ends of each joist, beam or girder shall have not less than 1 1/2 inches (38 mm) of bearing on wood or metal, have not less than 3 inches of bearing (76 mm) on masonry or concrete or be supported by *approved* joist hangers. Alternatively, the ends of joists shall be supported on a 1-inch by 4-inch (25 mm by 102 mm) ribbon strip and shall be nailed to the adjacent stud. The bearing on masonry or concrete shall be direct, or a sill plate of 2-inch minimum (51mm) nominal thickness shall be provided under the joist, beam or girder.
(Effective January 1, 2020)

SECTION R507 EXTERIOR DECKS

* Revise Figure R507.5.1(1) 'DECK BEAM TO DECK POST' to include a new illustration for "Corner Beam Over Post" as follows:

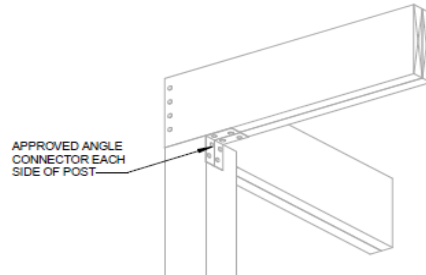

CORNER BEAM OVER POST

(Effective January 1, 2020)

*Revise R507.9.1.3 'Ledger to band joist details' to read as follows:

R507.9.1.3 Ledger to band joist details. Fasteners used in deck ledger connections in accordance with Table R507.9.1.3(1) shall be hot-dipped galvanized, stainless steel, or other approved fasteners and shall be installed in accordance with Table R507.9.1.3(2) and Figures R507.9.1.3(1) and R507.9.1.3(2).

(Effective January 1, 2020)

*Revise Figure R507.9.1.3 (2) 'Placement of Lag Screws and Bolts in Band Joists' as follows:

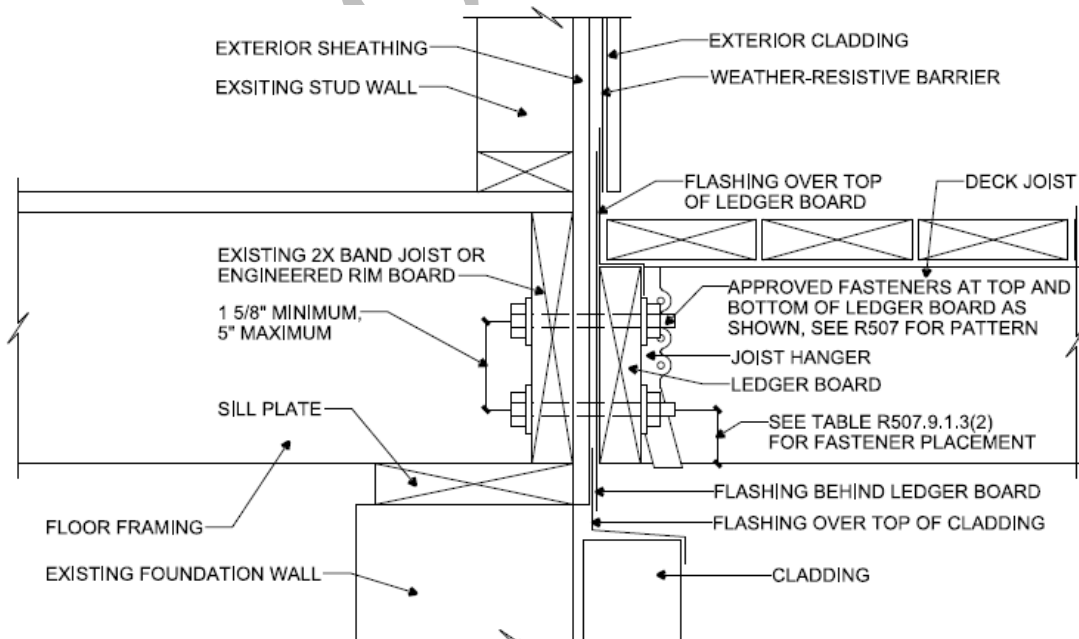

(WITH CLADDING)

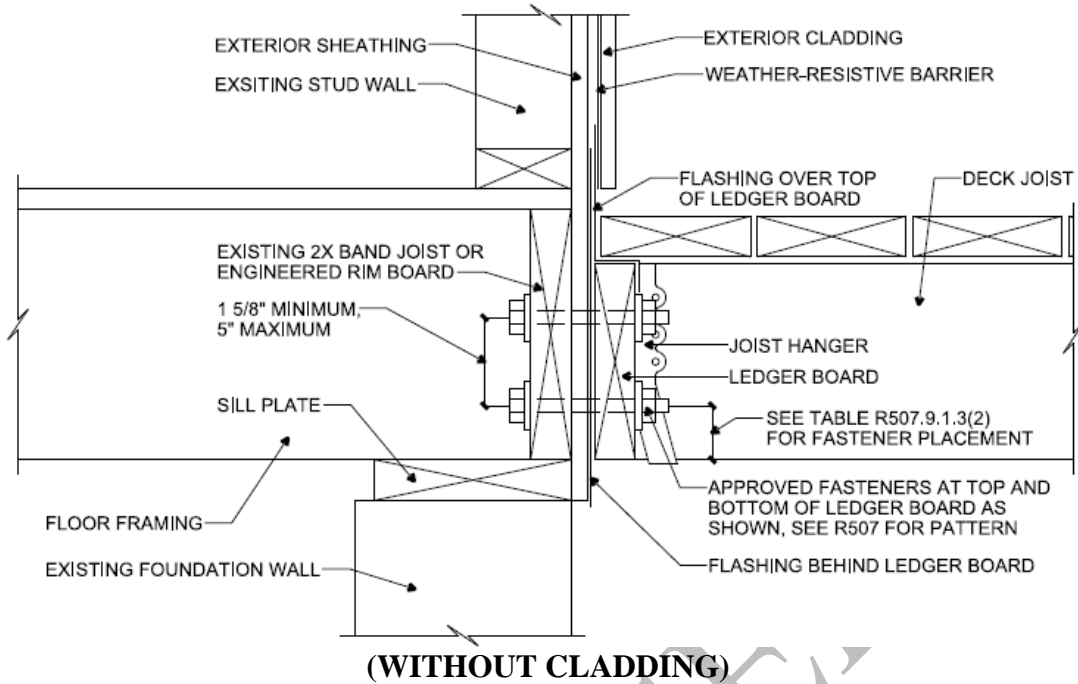

(WITHOUT CLADDING)
FIGURE R507.9.1.3(2)
PLACEMENT LAG SCREWS AND BOLTS IN BAND JOISTS
 (Effective January 1, 2020)

* Revise Figure R507.9.2(1) 'Deck Attachment for Lateral Loads' as follows:

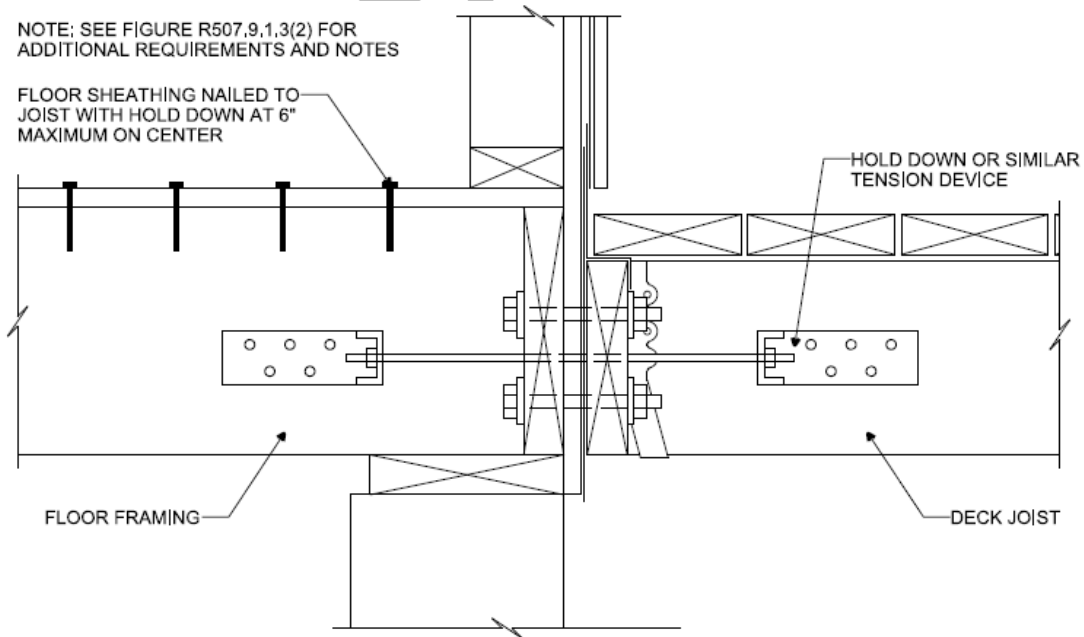

FIGURE R507.9.2(1)
DECK ATTACHMENT FOR LATERAL LOADS
 (Effective January 1, 2020)

*Revise Figure R507.9.2(2) 'Deck Attachment for Lateral Loads' and as follows:

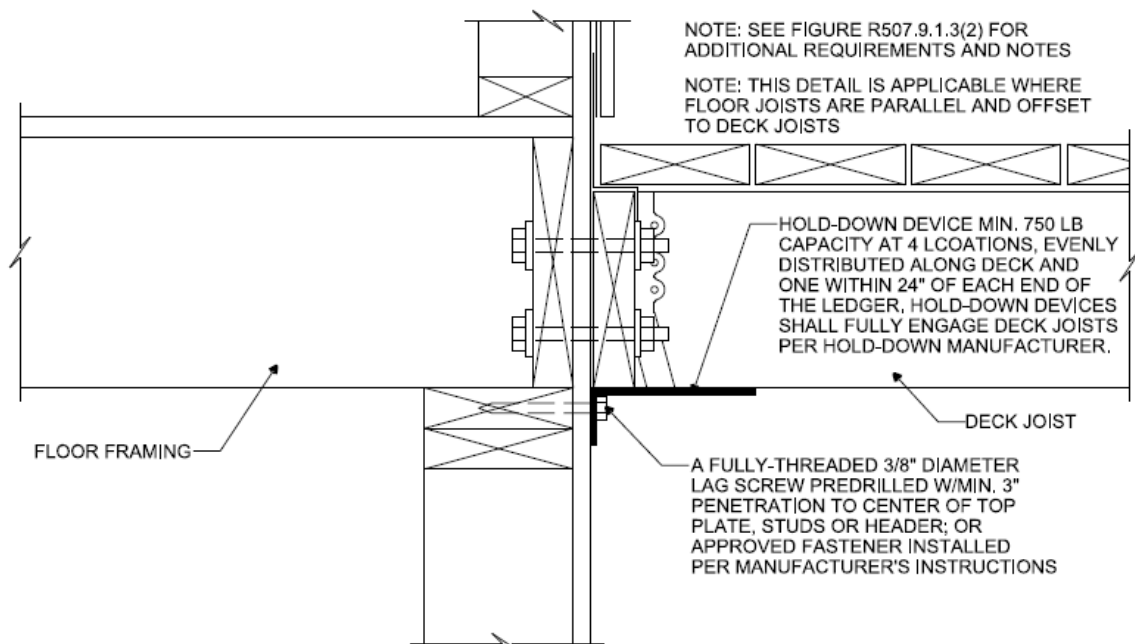

FIGURE R507.9.2(2)
DECK ATTACHMENT FOR LATERAL LOADS
(Effective January 1, 2020)

CHAPTER 6
WALL CONSTRUCTION

SECTION R602
WOOD WALL FRAMING

*Add new exception to R602.10 'Wall bracing' to read as follows:

R602.10 Wall bracing. Buildings shall be braced in accordance with this section or, when applicable, Section R602.12. Where a building, or portion thereof, does not comply with one or more of the bracing requirements in this section, those portions shall be designed and constructed in accordance with Section R301.1.

Exception: APA Simplified Wall Bracing Method, SR-102 may be used as an alternate method of wall bracing subject to limitations in document.
(Effective January 1, 2020)

**CHAPTER 8
ROOF-CEILING CONSTRUCTION**

**SECTION R806
ROOF VENTILATION**

*Delete R806.5 ‘Unvented attic and unvented enclosed rafter assemblies’ Item 5.2 without substitution.

(Effective January 1, 2020)

**SECTION R807
ATTIC ACCESS**

Add new Section R807.1.1 ‘Attic service access’ to read as follows:

R807.1.1 Attic service access. Attics containing appliances or mechanical equipment service shall be accessible by pull down stairs or other permanent steps and at a minimum be sized to allow the removal of the largest appliance.

(Effective January 1, 2020)

**CHAPTER 13
GENERAL MECHANICAL SYSTEM REQUIREMENTS**

**SECTION M1301
GENERAL**

*Revise Section M1301.2 ‘Identification’ to read as follows:

M1301.2 Identification. Each length of pipe and tubing and each pipe fitting utilized in a mechanical system shall bear the identification of the manufacturer. If not provided on the packaging or crating or by other approved documentation, each pipe fitting, utilized in a gas fuel system, shall bear the identification of the manufacturer.

(Effective January 1, 2020)

**CHAPTER 16
DUCT SYSTEMS**

**SECTION M1601
DUCT CONSTRUCTION**

*Delete Section M1601.1.1 ‘Above-ground duct systems’, Item 5 without substitution.

(Effective January 1, 2020)

*Revise Section M1601.1.1 ‘Above ground duct systems’, Item 7.1 as follows:

M1601.1.1 Above-ground duct systems. Above-ground *duct systems* shall conform to the following:

7. Stud wall cavities and the spaces between solid floor joists to be used as air plenums shall comply with the following conditions:

7.1 These cavities or spaces shall not be used as a plenum for supply or return air unless all such supply and return ducts are lined with metal, flex duct, duct board or other material that is approved in this section.

(Remainder of section unchanged.)

(Effective January 1, 2020)

CHAPTER 19 SPECIAL APPLIANCES, EQUIPMENT AND SYSTEMS

SECTION M1901 RANGES AND OVENS

*Revise Section M1901.2 ‘Cooking appliances’ to add a new exception to read as follows:

M1901.2 Cooking appliances. Cooking *appliances* shall be *listed* and *labeled* for household use and shall be installed in accordance with the manufacturer’s instructions. The installation shall not interfere with *combustion air* or access for operation and servicing. Electric cooking appliances shall comply with UL 1026 or UL 858. Solid-fuel-fired fireplace stoves shall comply with UL 737. Microwave ovens shall comply with UL 923.

Exception: Listed and labeled commercial cooking appliances may be installed in dwelling units and domestic kitchens when designed and accepted by a Georgia licensed Professional Engineer.

(Effective January 1, 2020)

CHAPTER 24 FUEL GAS

SECTION G2415 (404) PIPING SYSTEM INSTALLATION

*Delete Section G2415.6 (404.6) ‘Underground penetrations prohibited’ and substitute to read as follows:

G2415.6 (404.6) Piping through foundation wall. Underground piping where installed below grade through the foundation or basement wall of a building, shall be encased in a protective pipe sleeve. The annular space between the gas piping and the sleeve shall be sealed.

(Effective January 1, 2020)

*Revise Section G2415.7.1 (404.7.1) ‘Piping through bored holes or notches’ to read as follows:

G2415.7.1 (404.7.1) Piping through bored holes or notches. Where *piping* is installed through holes or notches in framing members and the *piping* is located less than 1 1/2 inches (38 mm) from the framing member face to which wall, ceiling or floor membranes will be attached, the pipe shall be protected by shield plates that cover the width of the pipe and the framing member. Where the framing member that the *piping* passes through is a bottom plate, bottom track, top plate or top track, the shield plates shall cover the framing member and extend not less than 4 inches (102 mm) above the bottom framing member and not less than 4 inches (102 mm) below the top framing member.

(Effective January 1, 2020)

*Delete Section G2415.7.2 (404.7.2) ‘Piping installed in other locations’ without substitution.

(Effective January 1, 2020)

*Delete Section G2415.11.1 (404.11.1) ‘Galvanizing’ without substitution.

(Effective January 1, 2020)

*Revise Section G2415.18 (404.18) ‘Pipe Cleaning’ to read as follows:

G2415.18 (404.18) Pipe debris removal. The interior of piping shall be clear of debris. The use of a flammable or combustible gas to clean or remove debris from a *piping system* shall be prohibited.

(Effective January 1, 2020)

SECTION G2420 (409) SHUTOFF VALVES

*Add new Section G2420.2.1 (409.2.1) ‘System shutoff valve’ to read as follows:

G2420.2.1 (409.2.1) System Shutoff Valve. Where the point of delivery is the outlet of the service meter assembly, or the outlet of the service regulator, a system shutoff valve shall be installed. Such valve is considered to be part of the customer piping system.

(Effective January 1, 2020)

SECTION G2423 (413) COMPRESSED NATURAL GAS MOTOR VEHICLE FUEL-DISPENSING FACILITIES

*Delete Section G2423.1 (413.1) ‘General’ and substitute to read as follows:

G2423.1 (413.1) General. Under Georgia law, the Rules and Regulations of the Georgia Safety Fire Commissioner govern the storage, delivery and dispensing of compressed natural gas. Refer to the Rules and Regulations of the Georgia Safety Fire Commissioner and NFPA 52 for all requirements concerning compressed natural gas motor vehicle fuel-dispensing stations.

(Effective January 1, 2020)

*Add new APPENDIX Q ‘TINY HOUSES’ to read as follows:

APPENDIX Q

TINY HOUSES

(The provisions contained in this appendix are not mandatory unless specifically referenced in the adopted ordinance.)

SECTION AS101 GENERAL

AQ101.1 Scope. This appendix shall be applicable to *tiny houses* used as single dwelling units. *Tiny houses* shall comply with this code except as otherwise stated in this appendix.

APPENDIX AS102 DEFINITIONS

AQ102.1 General. The following words and terms shall, for the purposes of this appendix, have the meanings shown herein. Refer to Chapter 2 of this code for general definitions.

EGRESS ROOF ACCESS WINDOW. A *skylight* or roof window designed and installed to satisfy the emergency escape and rescue opening requirements in Section R310.2.

LANDING PLATFORM. A landing provided as the top step of a stairway accessing a *loft*.

LOFT. A floor level located more than 30 inches (762 mm) above the main floor, open to the main floor on one or more sides with a ceiling height of less than 6 feet 8 inches (2032 mm) and used as a living or sleeping space.

LOFT. A floor level located more than 30 inches (762 mm) above the main floor, and open to it on at least one side with a ceiling height of a maximum of 5 feet, used as a living or sleeping space.

TINY HOUSE. A dwelling that is 400 square feet (37 m²) or less in floor area excluding *lofts*.

SECTION AS103 CEILING HEIGHT

AQ103.1 Minimum ceiling height. *Habitable space* and hallways in *tiny houses* shall have a finished ceiling height of not less than 6 feet 8 inches (2032 mm). Bathrooms, toilet rooms and kitchens shall have a ceiling height of not less than 6 feet 4 inches (1930 mm). Obstructions including, but not limited to, beams, girders, ducts and lighting, shall not extend below these minimum ceiling heights including beams, girders, ducts, lighting and other obstructions.

Exception: Ceiling heights in *lofts* are permitted to be less than 6 feet 8 inches (2032 mm) a maximum of 5 feet (1524 mm).

SECTION AS104 LOFTS

AQ104.1 Minimum loft area and dimensions. *Lofts* used as a sleeping or living space shall meet the minimum area and dimension requirements of Sections AS104.1.1 through AS104.1.3.

AQ104.1.1 Minimum area. *Lofts* shall have a floor area of not less than 35 square feet (3.25 m²).

AQ104.1.2 Minimum dimensions. *Lofts* shall be not less than 5 feet (1524 mm) in any horizontal dimension.

AQ104.1.3 Height effect on loft area. Portions of a *loft* with a sloped ceiling measuring less than 3 feet (914 mm) from the finished floor to the finished ceiling shall not be considered as contributing to the minimum required area for the loft.

Exception: Under gable roofs with a minimum slope of 6:12, portions of a *loft* with a sloped ceiling measuring less than 16 inches (406 mm) from the finished floor to the finished ceiling shall not be considered as contributing to the minimum required area for the *loft*.

AQ104.2 Loft access. The access to and primary egress from *lofts* shall be any type described in Sections AQ104.2.1 through AQ104.2.4.

AQ104.2.1 Stairways. Stairways accessing *lofts* shall comply with this code or with Sections AQ104.2.1.1 through AQ104.2.1.6.

AQ104.2.1.1 Width. Stairways accessing a *loft* shall not be less than 17 inches (432 mm) in clear width at or above the handrail. The minimum width below the handrail shall be not less than 20 inches (508 mm).

AQ104.2.1.2 Headroom. The headroom in stairways accessing a *loft* shall be not less than 6 feet 2 inches (1880 mm), as measured vertically, from a sloped line connecting the tread or landing platform nosings in the middle of their width.

AQ104.2.1.3 Treads and risers. Risers for stairs accessing a *loft* shall be not less than 7 inches (178 mm) and not more than 12 inches (305 mm) in height. Tread depth and riser height shall be calculated in accordance with one of the following formulas:

1. The tread depth shall be 20 inches (508 mm) minus $\frac{4}{3}$ of the riser height, or
2. The riser height shall be 15 inches (381 mm) minus $\frac{3}{4}$ of the tread depth.

AQ104.2.1.4 Landing platforms. The top tread and riser of stairways accessing *lofts* shall be constructed as a *landing platform* where the *loft* ceiling height is less than 6 feet 2 inches (1880 mm) where the stairway meets the *loft*. The *landing platform* shall be 18 inches to 22 inches (457 to 559 mm) in depth measured from the nosing of the landing platform to the edge of the *loft*, and 16 to 18 inches (406 to 457 mm) in height measured from the *landing platform* to the *loft* floor.

AQ104.2.1.4.1 Landing platform guards. Guards at the open side of landing platforms shall comply with Section R312.1 or shall be at least as high as the loft guard; whichever is greater.

AQ104.2.1.5 Handrails. Handrails shall comply with Section R311.7.8.

AQ104.2.1.6 Stairway guards. Guards at open sides of stairways shall comply with Section R312.1.

AQ104.2.2 Ladders. Ladders accessing *lofts* shall comply with Sections AS104.2.2.1 and AS104.2.2.2.

AQ104.2.2.1 Size and capacity. Ladders accessing *lofts* shall have a rung width of not less than 12 inches (305 mm), and 10 inches (254 mm) to 14 inches (356 mm) spacing between rungs. Ladders shall be capable of supporting a 300-pound (75 kg) load on any rung. Rung spacing shall be uniform within 3/8 inch (9.5 mm).

AQ104.2.2.2 Incline. Ladders shall be installed at 70 to 80 degrees from horizontal.

AQ104.2.3 Ships ladders. Ships ladders accessing *lofts* shall have a minimum tread depth of 5 inches (127 mm). The tread shall be projected such that the total of the tread depth plus the nosing projection is no less than 8 1/2 inches (216 mm). The maximum riser height shall be 9 1/2 inches (241 mm). Handrails shall be provided on both sides of ship ladders and shall comply with Section R311.7.8. Handrail height shall be uniform, not less than 30 inches (762 mm) and not more than 34 inches (864). The clear width at and below handrails shall be not less than 20 inches (508 mm). Compliant ship ladders may also access additional stories of a tiny house.

AQ104.2.4 Loft guards. *Loft* guards shall be located along the open side of *lofts*. *Loft* guards shall not be less than 36 inches (914 mm) in height or one-half of the clear height to the ceiling, whichever is less, but no less than 18 inches.

SECTION AQ105 EMERGENCY ESCAPE AND RESCUE OPENINGS

AQ105.1 General. *Tiny houses* shall meet the requirements of Section R310 for emergency escape and rescue openings.

Exception: *Egress roof access windows* in *lofts* used as sleeping rooms shall be deemed to meet the requirements of Section R310 where installed such that the bottom of the opening is not more than 44 inches (1118 mm) above the *loft* floor, provided the *egress roof access window* complies with the minimum opening area requirements of Section R310.2.1.

**SECTION AQ106
SMOKE AND CARBON MONOXIDE DETECTORS**

AQ106.1 SMOKE AND CARBON MONOXIDE DETECTORS. Smoke and carbon monoxide detectors shall be installed as required in Sections R314 and R315 and on the ceiling directly underneath any loft and just below the highest point of any loft.
(Effective January 1, 2020)

**APPENDIX U
DISASTER RESILIENT CONSTRUCTION**

*The Department of Community Affairs hereby adopts Appendix U ‘Disaster Resilient Construction’ as optional. This document is available to download free from DCA’s webpage at: https://dca.ga.gov/sites/default/files/appendix_u_-_irc_-_final_5-21-2018rev1.pdf
(Effective January 1, 2020)

End of Amendments.

PROPOSED



Georgia State
International Residential Code
Appendix U
Disaster Resilient Construction
(2020 Edition)



Georgia Department of Community Affairs
Community Development Division
60 Executive Park South, N.E.
Atlanta, Georgia 30329-2231
(404) 679-3118
www.dca.ga.gov

January 1, 2020

GEORGIA STATE INTERNATIONAL RESIDENTIAL CODE

APPENDIX U DISASTER RESILIENT CONSTRUCTION

The INTERNATIONAL RESIDENTIAL CODE, 2018 Edition, published by the International Code Council, when used in conjunction with the Georgia State Amendments to the INTERNATIONAL RESIDENTIAL CODE, 2018 Edition and Appendix U Disaster Resilient Construction, shall constitute the official *Georgia State Minimum Standard Residential Code*.

FORWARD

Introduction

The Department of Community Affairs (DCA) was awarded a grant through the U.S. Department of Housing and Urban Development (HUD) to develop Disaster Resilient Building Code (DRBC) Appendices for the International Building Code (IBC) and the International Residential Code (IRC). The DRBC Appendices are optional regulations that local jurisdictions may adopt, in whole or in part, through local ordinance. A task force of stakeholders was appointed to look for opportunities to improve any code provisions relating to damage from hurricane, flood, and tornado disasters. In addition to the approved recommendations from the task force, the state has developed and will conduct a comprehensive training program for code enforcement officials on the importance, implementation and enforcement of the Disaster Resilient Construction Appendices.

The meetings for the Disaster Resilient Building Code Appendices Task Force were open to the public, interested individuals and organizations that desired participation. The technical content of currently published documents on flooding, high-wind construction, and storm shelters, were used and referenced. Those publications included documents of the International Code Council (ICC), American Society of Civil Engineers (ASCE), the Federal Emergency Management Agency (FEMA), Mitigation Assessment Team (MAT) Program, Georgia Emergency Management Agency/Homeland Security (GEMA), APA – The Engineered Wood Association, National Institute of Standards and Technology (NIST), National Oceanic and Atmospheric Administration (NOAA), National Science Foundation (NSF), The State of Florida, American Forest & Paper Association’s American Wood Council, Southern Forest Products Association, NAHB Research Center, Insurance Institute for Business & Home Safety, and the Federal Alliance for Safe Homes.

Adoption

Local jurisdictions may adopt this entire appendix with chosen options or specific sections that apply to their communities through a local ordinance. The adopting ordinance must also be filed on record with DCA. A sample ordinance has been included in this document to assist the local jurisdictions with the adoption process. Recommended training is being offered to assist code enforcement officials in the implementation and enforcement of the appendices documents. Contact DCA at (404) 679-3118 or www.dca.ga.gov for more information.

Neither The Disaster Resilient Building Code Appendices Task Force, its members nor those participating in the development of Appendix U Disaster Resilient Construction accept any liability resulting from compliance or noncompliance with the provisions of Appendix U Disaster Resilient Construction.

The 2012 Disaster Resilient Building Code (DRBC) Appendices Task Force was charged with the development of two appendices. One appendix is for the International Residential Code and the other appendix is for the International Building Code. These two appendices look for opportunities to improve any provisions relating to hurricane, flood, and tornado disasters. In addition to improving existing provisions in the codes, the task force also developed new provisions to be included in the appendices that address these issues. These appendices contain increased construction requirements for disaster resilience and are intended to be made available for adoption by local jurisdictions in the State of Georgia.

These appendices have reasonable and substantial connection with the public health, safety, and general welfare. In addition, the financial impact and costs associated with these appendices have been taken into consideration.

Members:

Mr. Gregori Anderson, Chairman, States Codes Advisory Committee (SCAC)
Mr. David L. Adams, , Vice Chairman, States Codes Advisory Committee (SCAC)
Mr. Bill Abballe, AIA, American Institute of Architects (AIA) – Georgia Chapter
Mr. John Hutton, P.E., S.E., American Council of Engineering Companies of Georgia (ACEC/G)
Mr. Ron Anderson, Code Consultant
Mr. Lamar Smith, Home Builders Association of Georgia (HBAG)
Mr. Thomas Harper, Georgia State Inspectors Association (GSIA)
Mr. Tom Buttram, Building Officials Association of Georgia (BOAG)
Capt. Zane Newman, Georgia State Fire Marshal’s Office (Local Fire Official)
Mr. Terry Lunn, Georgia Emergency Management Agency (GEMA)
Mr. Alan Giles, CFM, Georgia Department of Natural Resources (EPD / Floodplain Management Unit)
Mr. Tony Hebert, HUD Georgia State Representative (Region IV Office)
Mr. Jim C. Beck, Sr., Georgia Underwriting Association
Mr. Tim Thornton, Georgia Association of Realtors (GAR)
Mr. Steve Harrison, Building Owners and Managers Association – Georgia (BOMA)
Mr. Tom Aderhold, Georgia Apartment Association (GAA)
Mr. Tim Bromley, Accessibility Consultant – Georgia State ADA Coordinator’s Office
Mayor Mark Mathews, Georgia Municipal Association (GMA)
Commissioner Jeff Long, Association of County Commissioners of Georgia (ACCG)

Ad Hoc Subcommittee:

Mr. Tom Buttram, Chairman, DRBC Task Force Liaison (BOAG)
Mr. Ron Anderson, Vice Chairman, Code Consultant
Mr. Stephen V. Skalko, P.E. Concrete Industry
Mr. Jeffrey B. Stone, PhD., Wood Industry (AWC)
Mr. Robert Wills, Steel Industry (AISC)
Mr. Tom Cunningham, PhD., Residential Building Design
Mr. Duncan J. Hastie, P.E., Disaster Mitigation

DCA Staff:

Mr. Ted Miltiades, Director of Construction Codes & Industrialized Buildings
Mrs. Deirdre “Dee” Leclair, DRBC Grant Project Manager
Mr. Max Rietschier, Lead Codes Consultant
Mr. Bill Towson, 2012 International Residential Code Task Force Liaison, Code Consultant
Mr. Calvin Jordan, 2012 International Building Code Task Force Liaison, Code Consultant

How to Use Appendix U Disaster Resilient Construction

The appendix may be adopted in whole or in part by Local Jurisdictions to fit the needs of their community. The following sample ordinance has been provided to aid in the process of identifying Chapters and Sections of the appendix that may be adopted. The format easily allows for choosing to adopt, revise or delete individual Chapters and Sections. Download the MS Word (.doc) version from the DCA website to take advantage of the dropdown menu choices and edit ability features of the document. Note that in Chapter 3, choose one of three options for flood elevation. Only one option may be chosen and that option must be higher than what has been previously adopted and enforced by your jurisdiction. Also note that in Chapter 4, choose one of four options for increased wind speed. Only one option may be chosen and that option must be higher than the mapped wind speed shown in the International Residential Code. The Sample Ordinance document takes into account the flood elevation option in Chapter 3 and the wind speed option in Chapter 4 of this appendix.

**SAMPLE ORDINANCE FOR ADOPTION OF
GEORGIA STATE INTERNATIONAL RESIDENTIAL CODE**

APPENDIX U

DISASTER RESILIENT CONSTRUCTION

ORDINANCE NO. _____

An ordinance of the [JURISDICTION] adopting the latest edition as adopted and amended by the Georgia Department of Community Affairs of *Appendix U Disaster Resilient Construction* regulating and governing the mitigation of hazard to life and property from natural weather related disasters, high-wind damages, flooding, and establishing construction standards for storm shelters in the [JURISDICTION]; providing for the issuance of permits and collection of fees therefore; repealing Ordinance No. ____ of the [JURISDICTION] and all other ordinances or parts of the laws in conflict therewith.

The [GOVERNING BODY] of the [JURISDICTION] does ordain as follows:

Section 1. That a certain document, three (3) copies of which are on file in the office of the [TITLE OF JURISDICTION'S KEEPER OF RECORDS] of [NAME OF JURISDICTION], being marked and designated as *Appendix U Disaster Resilient Construction* to the International Residential Code, the latest edition as adopted and amended by the Georgia Department of Community Affairs, be and is adopted as the *Appendix U Disaster Resilient Construction* of the [JURISDICTION], in the State of Georgia for regulating and governing the mitigation of hazard to life and property from natural weather related disasters, high-wind damages, flooding, and establishing construction standards for storm shelters; providing for the issuance of permits and collection of fees therefore; and each and all of the regulations, provisions, penalties, conditions and terms of said *Appendix U Disaster Resilient Construction* on file in the office of the [JURISDICTION] are hereby referred to, adopted, and made a part hereof, as if fully set out in this ordinance, with the additions, insertions, deletions and changes, if any prescribed in Section 2 of this ordinance.

Section 2. [NAME OF JURISDICTION] hereby:

Choose an item. CHAPTER AU1 SCOPE AND ADMINISTRATION Choose an item.

Choose an item. SECTION AU101 ADMINISTRATION Choose an item.

Choose an item. AU101.1 Purpose Choose an item.

Choose an item. AU101.2 Objectives Choose an item.

Choose an item. AU101.3 Scope Choose an item.

AU101.3.1 Insert [Name Of Jurisdiction] for [NAME OF JURISDICTION].

Choose an item. AU101.4 Violations Choose an item.

Insert [Name Of Jurisdiction] for [NAME OF JURISDICTION].

Choose an item. SECTION AU102 APPLICABILITY Choose an item.

Choose an item. AU102.1 General Choose an item.

Choose an item. AU102.2 Other laws Choose an item.

Choose an item. AU102.3 Referenced codes and standards Choose an item.

Choose an item. SECTION AU103 POST DISASTER EVENT INSPECTIONS GUIDELINES Choose an item.

Choose an item. AU103.1 Inspections Choose an item.

Choose an item. AU103.1.1 Right of entry Choose an item.

Choose an item. AU103.2 Types of inspections Choose an item.

Choose an item. AU103.3 Post disaster building safety evaluation chart Choose an item.

Choose an item. Figure AU103.3 Post Disaster Building Safety Evaluation Chart Choose an item.

Choose an item. AU103.4 Evaluation forms Choose an item.

Insert [Name Of Jurisdiction] for [NAME OF JURISDICTION].

Choose an item. AU103.5 Placement and remove of placards Choose an item.

Choose an item. CHAPTER AU2 DEFINITIONS Choose an item.

Choose an item. SECTION AU201 GENERAL Choose an item.

Choose an item. AU201.1 Scope Choose an item.

Choose an item. AU201.2 Terms defined in other codes Choose an item.
Choose an item. AU201.3 Terms not defined Choose an item.
Choose an item. SECTION AU202 DEFINITIONS Choose an item.
Choose an item. CHAPTER AU3 FLOOD-RESISTANT CONSTRUCTION Choose an item.
Choose an item. SECTION AU301 HAZARD IDENTIFICATION Choose an item.
Choose an item. AU301.1 Identification of flood hazard areas Choose an item.
Insert [Name Of Jurisdiction] for [NAME OF JURISDICTION].
Insert [Date] for [INSERT DATE ISSUANCE].
Choose an item. SECTION AU302 SCOPE Choose an item.
Choose an item. AU302.1 Flood loads Choose an item.
Choose an item. FLOOD ELEVATION OPTION Choose an item. Choose an item.
Choose an item. SECTION AU303 FLOOD DAMAGE-RESISTANT MATERIALS Choose an item.
Choose an item. AU303.1 Flood damage-resistant materials Choose an item.
Choose an item. AU303.2 Location of flood damage-resistant materials Choose an item.
Choose an item. AU303.3 Fasteners and connectors used for flood-resistant materials Choose an item.
Choose an item. CHAPTER AU4 HIGH-WIND RESISTIVE CONSTRUCTION Choose an item.
Choose an item. SECTION AU401 GENERAL Choose an item.
Choose an item. AU401.1 Scope Choose an item.
Choose an item. AU401.2 Continuous load path Choose an item.
Choose an item. AU401.3 Adoption of wind speed Choose an item.
[Name Of Jurisdiction] adopts Option Choose an item.
Choose an item. SECTION Choose an item. Choose an item.
Choose an item. SECTION AU406 FASTENERS AND CONNECTIONS FOR CLADDING Choose an item.
Choose an item. AU406.1 Fasteners and connectors for cladding Choose an item.
Choose an item. SECTION AU407 FENESTRATION Choose an item.
Choose an item. AU407.1 Design pressure Choose an item.
Choose an item. AU407.2 Anchorage methods Choose an item.
Choose an item. SECTION AU408 ROOFING Choose an item.
Choose an item. AU408.1 Secondary water barrier Choose an item.
Choose an item. AU408.2 Fasteners Choose an item.
Choose an item. AU408.3 Attachment Choose an item.
Choose an item. CHAPTER AU5 RESIDENTIAL STORM SHELTERS AND SAFE ROOMS Choose an item.
Choose an item. SECTION AU501 GENERAL Choose an item.
Choose an item. AU501.1 General Choose an item.
Choose an item. SECTION AU502 RESIDENTIAL STORM SHELTERS AND SAFE ROOMS Choose an item.
Choose an item. AU502.1 Residential storm shelters Choose an item.
Choose an item. AU502.2 Residential safe rooms Choose an item.

Section 3. That Ordinance No. ____ of [JURISDICTION] entitled [FILL IN HERE THE COMPLETE TITLE OF THE LEGISLATION OR LAWS IN EFFECT AT THE PRESENT TIME SO THAT THEY WILL BE REPEALED BY DEFINITE MENTION] and all other ordinances or parts of laws in conflict herewith are hereby repealed.

Section 4. That if any section, subsection, sentence, clause or phrase of this ordinance is, for any reason, held to be unconstitutional, such decision shall not affect the validity of the remaining portions of this ordinance. The [GOVERNING BODY] hereby declares that it would have passed this law, and each section, subsection, clause or phrase thereof, irrespective of the fact that any one or more sections, subsections, sentences, clauses and phrases be declared unconstitutional.

Section 5. That nothing in this ordinance or in *Appendix U Disaster Resilient Construction* hereby adopted shall be construed to affect any suit or proceeding impending in any court, or any rights acquired, or liability incurred, or any cause or causes of action acquired or existing under any act or ordinance hereby repealed as cited in Section 3 of this ordinance; nor shall any just or legal right or remedy of any character be lost, impaired or affected by this ordinance.

Section 6. That the [JURISDICTION'S KEEPER OF RECORDS] is hereby ordered and directed to cause this ordinance to be published. (An additional provision may be required to direct the number of times the ordinance is to be published and to specify that it is to be in a newspaper in general circulation. Posting may also be required.)

Section 7. That this ordinance and the rules, regulations, provisions, requirements, orders and matters established and adopted hereby shall take effect and be in full force and effect [TIME PERIOD] from and after the date of its final passage and adoption.

Section 8. Chapter AU6 Resources of this document is intended to be used by the building officials as a resource guide.

PROPOSED

TABLE OF CONTENTS

CHAPTER AU1 Scope and Administration	8	CHAPTER AU5 Residential Storm Shelters and Safe Rooms	21
Section		Section	
AU101 Administration	8	AU501 General	21
AU102 Applicability	8	AU502 Residential Storm Shelters and Safe Rooms . .	21
AU103 Post Disaster Event Inspections Guidelines . . .	9		
CHAPTER AU2 Definitions	11	CHAPTER AU6 Resources	22
Section		Section	
AU201 General	11	AU601 Contacts	22
AU202 Definitions	11	AU602 Emergency Inspection Kit	22
		AU603 Safety Tips	23
CHAPTER AU3 Flood-resistant Construction	12	AU604 Major Disaster Process	23
Section		AU605 Sample Evaluation Forms and Inspected Placards	23
AU301 Hazard Identification	12		
AU302 Scope	12	CHAPTER AU7 References	30
AU303 Flood Damage-Resistant Materials	12		
		INDEX OF FIGURES	30
CHAPTER AU4 High-wind Resistive Construction	13		
Section			
AU401 General	13		
AU402 Option A – Minimum Wind Speed 100 MPH .13			
AU403 Option B – Minimum Wind Speed 110 MPH .19			
AU404 Option C – Minimum Wind Speed 120 MPH .19			
AU405 Option D – Minimum Wind Speed 130 MPH .19			
AU406 Fasteners and Connectors for Cladding	19		
AU407 Fenestrations	19		
AU408 Roofing	20		

APPENDIX U DISASTER RESILIENT CONSTRUCTION

CHAPTER AU1 SCOPE AND ADMINISTRATION

SECTION AU101 ADMINISTRATION

AU101.1 Purpose. The scope of this appendix is to promote enhanced public health, safety and general welfare and to reduce public and private property losses due to hazards and natural disasters associated with flooding, high-winds, and windborne debris above that which is provided in the general provisions of this appendix.

AU101.2 Objectives. The objectives of this appendix are to:

1. Protect human life, to minimize property loss and to minimize the expenditures of public money associated with natural weather related disasters, including flooding, tornadoes and other high-wind events.
2. Establish enhanced design and construction regulations consistent with nationally recognized good practices for the safeguarding of life and property.

AU101.3 Scope.

AU101.3.1 The provisions of this appendix are not mandatory unless specifically referenced in an adopting ordinance of [NAME OF JURISDICTION]. If adopted, the provisions shall apply to all new development and to substantial improvements to existing development.

AU101.3.2 The provisions of this appendix supplement the jurisdiction's building codes to provide for enhanced provisions to mitigate the hazard to life and property from natural weather related disasters, including flooding, tornadoes and other high-wind events.

AU101.3.3 The provisions of this appendix establish design and construction standards for storm shelters.

AU101.4 Violations. Any violation of a provision of this appendix or failure to comply with a permit of variance issued pursuant to this appendix or any requirement of this appendix shall be handled in accordance with the ordinances of [NAME OF JURISDICTION].

SECTION AU102 APPLICABILITY

AU102.1 General. This appendix provides enhanced minimum requirements for development of new construction and substantial improvement of existing development above that contained in the *International Residential Code* (IRC).

AU102.1.1 Regardless of the category of work being performed, the work shall not cause the structure to become unsafe or adversely affect the performance of the building; shall not cause an existing mechanical or plumbing system to become unsafe, hazardous, insanitary or overloaded; and unless expressly permitted by these provisions, shall not make the building any less compliant with this appendix or to any previously approved alternative arrangements than it was before the work was undertaken.

AU102.1.2 Where there is a conflict between a requirement of the *International Residential Code* and a requirement of this appendix, the requirement of this appendix shall govern. Where there is a conflict between a general requirement of this appendix and a specific requirement of this appendix, the specific requirement shall govern. Where, in any specific case, different sections of this appendix specify different materials, methods of construction or other requirements, the most restrictive shall govern.

AU102.2 Other laws. The provisions of this appendix shall not be deemed to nullify any provisions of local, state or federal law.

AU102.3 Referenced codes and standards. The codes and standards referenced in this appendix shall be those that are listed in Chapter AR7 and such codes and standards shall be considered as part of the requirements of this appendix to the prescribed extent of each such reference. Where differences occur between provisions this appendix and references and standards, the provisions of this appendix shall apply.

SECTION AU103
POST DISASTER EVENT INSPECTIONS
GUIDELINES

AU103.1 Inspections. The building official or agents shall inspect residential buildings and structures to determine the habitability of each with the goal of getting the community back into their residences quickly and safely. Inspections shall always be performed by teams of at least two individuals, also known as disaster assessment teams.

AU103.1.1 Right of entry. Unless permitted under the exigent circumstances provisions or from an order from State or Federal Authorities, disaster assessment teams shall confirm the right of entry requirements with the incident commander. Upon approval, the assessment teams shall be authorized to enter the structure or premises at reasonable times to inspect or perform duties as provided by this code, provided that the structure or premises be occupied, that credentials are presented, that entry is requested, and that entry is granted by the owner or person having charge over the structure or premises.

AU103.2 Types of inspections.

AU103.2.1 Rapid evaluation. Rapid evaluation is performed after a disaster event to determine if a building is apparently safe or obviously unsafe. The evaluation should last 10 to 30 minutes per building and shall be performed by the building official and/or their designated responders. Evaluation shall determine if a detailed evaluation is necessary. Placards are posted on buildings indicating status as one of the following:

1. INSPECTED
2. RESTRICTED USE
3. UNSAFE

See Section AU605 for Placards that may be reproduced for use in the field during evaluations. The jurisdiction shall alter placards to meet the jurisdiction and building department's requirements.

AU103.2.2 Detailed evaluation. Detailed evaluation is a thorough visual examination of a damaged building performed by a team of two, including an inspector and a design professional. Evaluation should last 30 minutes to 4 hours per building. Evaluation shall determine necessary restrictions on a damaged building's use, the need for an engineering evaluation or to evaluate postings.

AU103.2.3 Engineering evaluation. When indicated by the building official as necessary, engineering evaluations shall be completed by a registered design professional hired by the building owner.

AU103.3 Post disaster building safety evaluation Chart. See Figure AU103.3 for Post Disaster Building Safety Evaluation Chart.

AU103.4 Evaluation forms. *ATC-45 Rapid Evaluation Safety Assessment Form* and *ATC-45 Detailed Evaluation Safety Assessment Form* shall be used by [NAME OF JURISDICTION]'s Building Official for post disaster inspections. See Section AU605 for copies of the Safety Assessment Forms.

AU103.5 Placement and removal of placards.

AU103.5.1 Placement. Placards are to be posted in a clearly visible location near the main entrance and shall be visible from the public right-of-way. In addition RESTRICTED USE or UNSAFE placards shall be placed at all entrances.

AU103.5.2 Removal. Placards shall not be removed or replaced, except by the authorized representatives of the local jurisdiction.

Figure AU103.3 Post Disaster Building Safety Evaluation Chart ^a

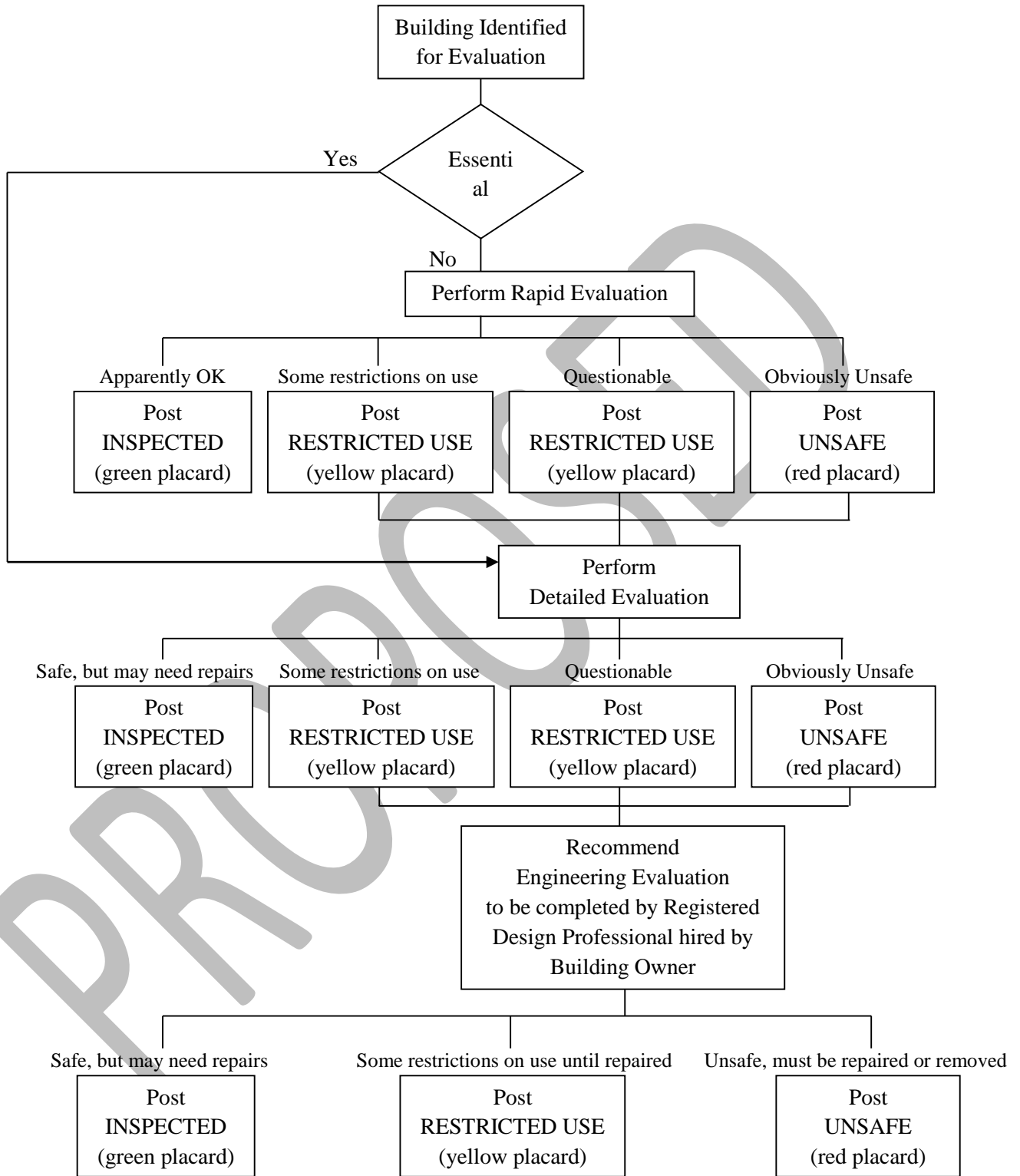

^(a) *When Disaster Strikes* by the International Code Council, Inc., Seventh Printing: November 2011, copyright 2007

CHAPTER AU2 DEFINITIONS

SECTION AU201 GENERAL

AU201.1 Scope. Unless otherwise expressly stated the following words and terms shall, for the purposes of this appendix, have the meanings shown in this chapter.

AU201.2 Terms defined in other codes. Where terms are not defined in this appendix and are defined in other *International Codes*, such terms shall have the meanings ascribed to them as in those codes.

AU201.3 Terms not defined. Where terms are not defined through the methods authorized by this section, such terms shall have their ordinarily accepted meanings such as the context implies.

SECTION AU202 DEFINITIONS

500-YEAR FLOOD. Flood having a 0.2% annual probability of being equaled or exceeded.

ADVISORY BASE FLOOD ELEVATION (ABFE). An advisory base flood elevation (BFE) issued by the Federal Emergency Management Agency (FEMA) that reflects post-storm conditions and vulnerability to damages from future flooding.

BASE FLOOD. Flood having a 1% chance of being equaled or exceeded in any given year, also referred to as the 100-year flood.

BASE FLOOD ELEVATION (BFE). The elevation of flooding, including wave height, having a 1% chance of being equaled or exceeded in any given year established relative to the National Geodetic Vertical Datum (NGVD), North American Vertical Datum (NAVD) or other datum specified on the *Flood Insurance Rate Map* (FIRM).

BUILDING OFFICIAL. The officer or other designated authority charged with the administration and enforcement of the *International Residential Code*, or the building official's duly authorized representative.

DESIGN FLOOD. The greater of the following two flood events:

- (1) The *base flood*, affecting those areas identified as *special flood hazard areas* on the community's FIRM;

- (2) The flood corresponding to the area designated as a *flood hazard area* on a community's *flood hazard map* or otherwise legally designated.

DESIGN FLOOD ELEVATION (DFE). The elevation of the *design flood*, including wave height, relative to the datum specified on the community's legally designated flood hazard map. In areas designated as Zone AO, the *design flood elevation* shall be the elevation of the highest existing grade of the building's perimeter plus the depth number (in feet) specified on the flood hazard map.

FLOOD [DAMAGE]-RESISTANT MATERIAL. Any building product [material, component or system] capable of withstanding direct and prolonged contact with floodwaters without sustaining significant damage.

FLOOD HAZARD AREA. The area subject to flooding during the *design flood*.

FLOOD HAZARD MAP. Map delineating *flood hazard areas* adopted by the authority having jurisdiction.

FLOOD INSURANCE RATE MAP (FIRM). An official map of a community on which the Federal Emergency Management Agency (FEMA) has delineated both the *special flood hazard areas* and the risk premium zones applicable to the community.

FREEBOARD. A factor of safety expressed in feet above a flood level for purposes of floodplain management.

FUTURE-CONDITIONS FLOOD. The flood having a 1% chance of being equaled or exceeded in any given year based on future-conditions hydrology. Also known as the 100-year future-conditions flood.

FUTURE-CONDITIONS FLOOD ELEVATION. The flood standard equal to or higher than the Base Flood Elevation. The future-conditions flood elevation is defined as the highest water surface anticipated at any given point during the future-conditions flood.

CHAPTER AU3 FLOOD-RESISTANT CONSTRUCTION

Forward: This appendix provides three different options for increased freeboard. The jurisdiction may pick only one option that is higher than previously adopted and enforced by the jurisdiction. The National Flood Insurance Program (NFIP) minimum standards reference Base Flood Elevation without any freeboard in high risk flood hazard areas. Due to the flood damage prevention updates performed during the Map Modernization initiative that led to flood risks being digitally identified in all 159 Georgia counties, all Georgia NFIP participating communities have freeboard standards that meet or exceed the 1 foot standard used in the State model ordinances for areas where BFEs have been established.

SECTION AU301 HAZARD IDENTIFICATION

AU301.1 Identification of flood hazard areas. To establish flood hazard areas:

- (a) flood hazard map adopted by jurisdiction based on areas of special flood hazard as identified by the Federal Emergency Management Agency in an engineering report entitled “The Flood Insurance Study of [INSERT NAME OF JURISDICTION],” dated [INSERT DATE ISSUANCE], and amended or revised with the accompanying Flood Insurance Rate Map (FIRM) and Flood Boundary and Floodway Map (FBFM) and related supporting data along with any revisions thereto.
- (b) FIRM maps provided by the Federal Emergency Management Agency.

SECTION AU302 SCOPE

AU302.1 Flood loads. Buildings designed and constructed in flood hazard areas defined in Table R301.2(1) of the *International Residential Code* shall comply with the following:

AU302.1.1 Flood hazard areas without base flood elevations. In flood hazard areas without base flood or future-conditions flood elevation data, new construction and substantial improvements of existing structures shall have the lowest floor of the lowest enclosed area (including basement) elevated no less than three (3) feet above the highest adjacent grade to the building foundation.

OPTION A – FLOOD ELEVATION

AU302.1.2 Increase to base flood elevation requirements. Floors required by ASCE 24 to be built above base flood elevations as follows:

The higher of:

- (a) Design flood elevation plus one (1) foot, or
- (b) Base flood elevation plus one (1) foot, or
- (c) Advisory base flood elevation, or

- (d) Future-conditions plus one (1) foot, if known or
- (e) 500-year flood, if known

OPTION B – FLOOD ELEVATION

AU302.1.3 Increase to base flood elevation requirements. Floors required by ASCE 24 to be built above base flood elevations as follows:

The higher of:

- (a) Design flood elevation plus two (2) feet, or
- (b) Base flood elevation plus two (2) feet, or
- (c) Advisory base flood elevation, or
- (d) Future-conditions plus one (1) foot, if known or
- (e) 500-year flood, if known

OPTION C – FLOOD ELEVATION

AU302.1.4 Increase to base flood elevation requirements. Floors required by ASCE 24 to be built above base flood elevations as follows:

The higher of:

- (a) Design flood elevation plus three (3) feet, or
- (b) Base flood elevation plus three (3) feet, or
- (c) Advisory base flood elevation, or
- (d) Future-conditions plus one (1) foot, if known or
- (e) 500-year flood, if known

SECTION AU303 FLOOD DAMAGE-RESISTANT MATERIALS

AU303.1 Flood damage-resistant materials. Flood damage-resistant materials comply with FEMA Technical Bulletin 2, Table 2. Types, Uses, and Classifications of Materials.

AU303.2 Location of flood damage-resistant materials. Building components and materials located below the increase to base flood elevation as determined by the local jurisdiction in accordance with AU302.1 shall be flood damage-resistant as defined by Section AU303.1.

AU303.3 Fasteners and connectors used for flood damage-resistant materials. Fasteners and connectors used for flood damage-resistant materials to be made of stainless steel, hot-dipped zinc-coated galvanized steel, mechanically deposited-zinc coated, silicon bronze or copper. Copper fasteners shall not be permitted for use in conjunction with steel.

CHAPTER AU4 HIGH-WIND RESISTIVE CONSTRUCTION

Forward: This appendix provides four different options for increased wind speed. The jurisdiction may pick only one option that is higher than the mapped wind speed shown in the International Residential Code.

SECTION AU401 GENERAL

AU401.1 Scope. The provisions of this appendix shall govern the structural design of one- and two-family dwellings (townhouses) not more than three stories in height with separate means of egress and their accessory structures. The building or structure shall comply with all aspects of the International Residential Code in addition to the requirements of this appendix.

AU401.2 Continuous load path. A continuous load path shall be provided to transmit the applicable forces from the roof assembly to the foundation.

AU401.3 Adoption of wind speed. [INSERT NAME OF JURISDICTION] adopts Option [PICK A, B, C, or D] MINIMUM WIND SPEED [INSERT WIND SPEED].

AU401.4 Alternative materials, design and methods of construction and equipment. The provisions of this appendix are not intended to prevent the installation of any material or to prohibit any design or method of construction not specifically prescribed by this appendix, provided such material is listed and tested for such application intended. An alternative material, design or method of construction shall be *approved* where the *building official* finds that the proposed design is satisfactory and complies with the intent of the provisions of this appendix, and that the material, method or work offered is, for the purpose intended, at least the equivalent of that prescribed in this appendix. Compliance with the specific performance-based provisions of the International Codes in lieu of specific requirements of this appendix shall also be permitted as an alternate.

AU401.4.1 Tests. Whenever there is insufficient evidence of compliance with the provisions of this appendix, or evidence that a material or method does not conform to the requirements of this appendix, or in order to substantiate claims for alternative materials or methods, the *building official* shall have the authority to require tests as evidence of compliance to be made at no expense to the *jurisdiction*. Test methods shall be as specified in this appendix or by other recognized test standards. In the absence of recognized and accepted test methods, the *building official* shall approve the testing procedures. Tests shall be performed by an *approved*

agency. Reports of such tests shall be retained by the *building official* for the period required for retention of public records.

SECTION AU402 OPTION A – MINIMUM WIND SPEED 100 MPH

AU402.1 Wind speed. Buildings shall be designed and constructed to comply with minimum wind speed of 100 mph Exposure B in accordance with AU402.1.1 or in accordance with Prescriptive Method AU402.2. Buildings with minimum wind speed of 100 mph Exposure C shall be in accordance with AU402.1.1.

AU402.1.1 Design methods. The design of buildings for wind loads shall be in accordance with one or more of the following methods:

1. AF&PA Wood Frame Construction Manual (WFCM), or
2. AF&PA Wood Frame Construction Manual Guide to Wood Construction in High Wind Areas for One- and Two-Family Dwellings: 100 MPH Exposure B (WFCM); or
3. ICC Standard for Residential Construction in High-Wind Regions (ICC 600); or
4. ASCE Minimum Design Loads for Buildings and Other Structures (ASCE 7); or
5. AISI Standard for Cold-Formed Steel Framing – Prescriptive Method For One- and Two-Family Dwellings (AISI S230); or
6. International Building Code; or
7. Concrete walls in accordance with R404 and R608 of the International Residential Code; or
8. Walls of structural insulated panels in accordance with R610 of the International Residential Code.

AU402.2 Prescriptive wood frame construction method deemed to comply with 100 MPH Exposure B. Prescriptive construction method for wood frame structures shall be in accordance with IRC requirements for 100 mph Exposure B construction as modified in this section. A continuous load path shall be provided to transmit uplift forces from the roof assembly to the ground as follows:

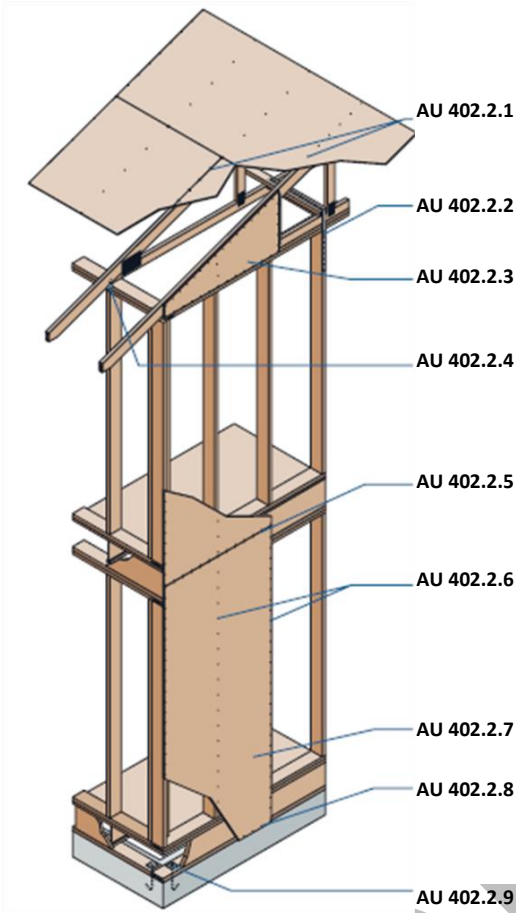

Figure U402.2^b

(b) Form No. M310B © 2011 APA – The Engineered Wood Association.

AU402.2.1 Roof sheathing attachment. Nail roof sheathing with 8d ring shank (or deformed shank) (0.131" x 2-1/2") nails at 4 inches on center along the ends of the sheathing and gable end framing 6 inches on center along intermediate framing. See Figure AU402.2.1.

AU402.2.2 Gable end wall connection. Tie gable end walls back to the structure. See Figure AU402.2.2.

AU402.2.3 Gable end wall sheathing. Continuously sheath gable end walls with wood structural panels or equivalent approved material meeting loading requirements. See Figure AU402.2.3.

AU402.2.4 Roof framing to wall connection. Connect roof framing to wall using an approved connector or connectors having allowable loads when attached to Southern Pine or Douglas Fir lumber of 585 pounds in the upward direction, 485 pounds in the direction parallel to the wall and 165 pounds in the direction perpendicular

to the wall. Attachment to be on exterior face of the exterior walls. See Figure AU402.2.4.

AU402.2.5 Sheathing attachment at elevated floor level. Nail upper story sheathing and lower story sheathing into common wood structural panel or engineered rim board. See Figure AU402.2.5.

AU402.2.6 Wall sheathing attachment. Attach wall sheathing with 8d common (0.131" x 2-1/2") nails at 4 inches on center at end and edges of wood structural panels and 6 inches on center in the intermediate framing. See Figure AU402.2.6a. Adjacent edges in wood structural panel wall sheathing that do not occur over common framing members shall be attached to flat wise blocking as illustrated in Figure AU402.2.6b.

AU402.2.7 Continuous wall sheathing. Continuously sheath all walls with wood structural panels or equivalent approved material meeting loading requirements. Continuously sheath areas around openings for windows and doors. Minimum wall bracing requirements shall be in accordance with IRC Section R602.10 or R602.12 continuous sheathing methods as modified in Section AU402.2.

AU402.2.8 Wall sheathing to sill plate connection. Extend sheathing material to lap the sill plate. See Figure AU402.2.8.

AU402.2.9 Anchor bolt connection. Space 1/2" anchor bolts with 7 inches of embedment 48 inches on center with 0.229" x 3" x 3" square plate washers with slotted holes. See Figure AU402.2.9. There shall be a minimum of 2 bolts per plate section with one bolt located not more than 12" or less than 3.5" from each end of the plate section.

AU402.2.10 Top plate intersection detail. Double top plates shall be provided at the top of all exterior stud walls. The double plates shall overlap at corners and at intersections with other exterior or interior load bearing walls. Double top plates shall be lap-spliced with end joints offset in accordance with the minimum requirements given in the *WFCM Guides to Wood Construction in High Wind Areas for One- and Two-Family Dwellings: 100 MPH Exposure B*. See Figure AU402.2.10.

AU402.3 Wall openings. Uplift load path connections at wall openings shall be in accordance with IRC Section R602.3.5.

NAIL ROOF SHEATHING WITH 8d RING SHANK (0.131" X 2-1/2") OR DEFORMED SHANK NAILS AT 4" ON CENTER ALONG THE ENDS OF THE SHEATHING AND GABLE END FRAMING 6 INCHES ON CENTER ALONG INTERMEDIATE FRAMING

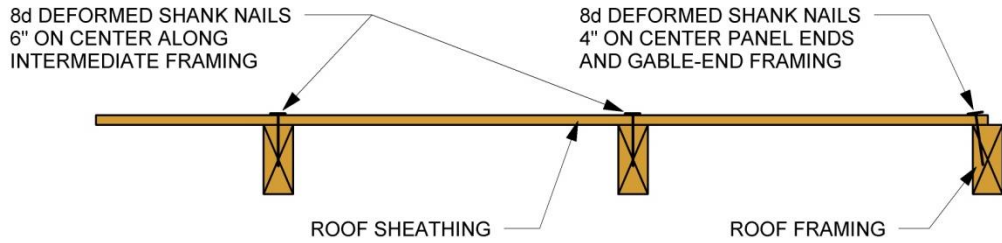

Figure AU402.2.1^b
Roof Sheathing Attachment Detail

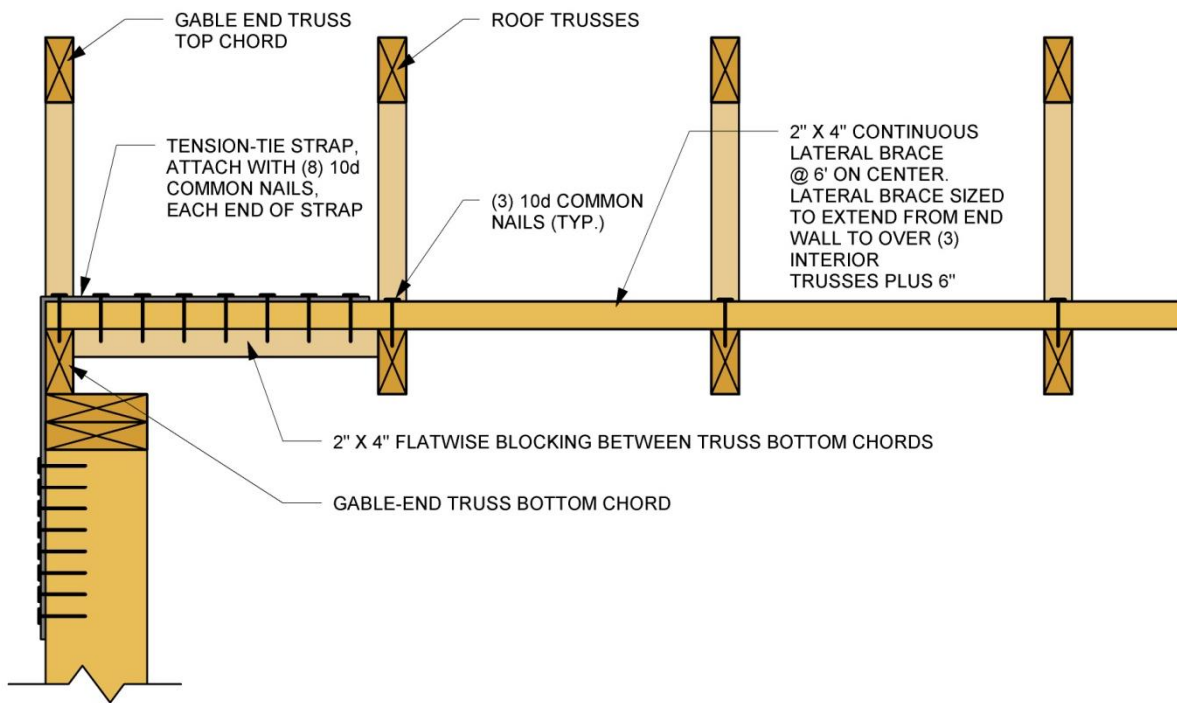

Figure AU402.2.2^b
Gable End Wall Connection Detail

SHEATH GABLE END WALLS WITH WOOD STRUCTURAL PANELS OR EQUIVALENT APPROVED MATERIAL MEETING LOADING REQUIREMENTS

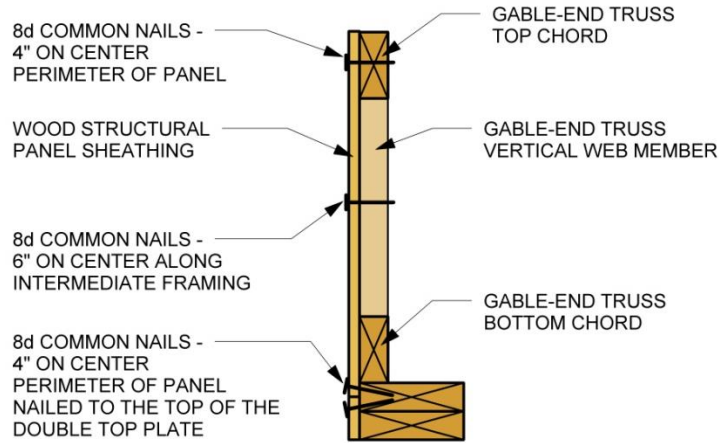

Figure AU402.2.3^b
Gable End Wall Sheathing Detail

ROOF FRAMING TO WALL CONNECTION WITH FRAMING ANCHOR TO MEET UPLIFT AND SHEAR CAPACITY ATTACHED ON SHEATHING SIDE OF THE EXTERIOR WALLS

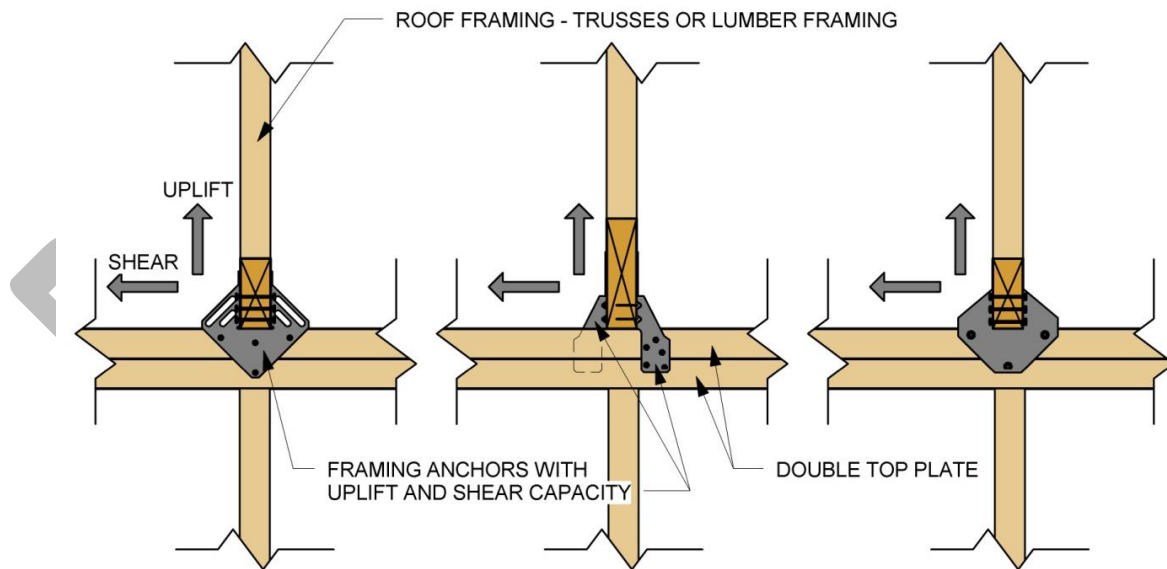

Figure AU402.2.4^b
Roof Framing to Wall Connection Detail

NAIL OFF UPPER STORY AND LOWER STORY SHEATHING INTO COMMON WOOD STRUCTURAL PANEL RIM BOARD

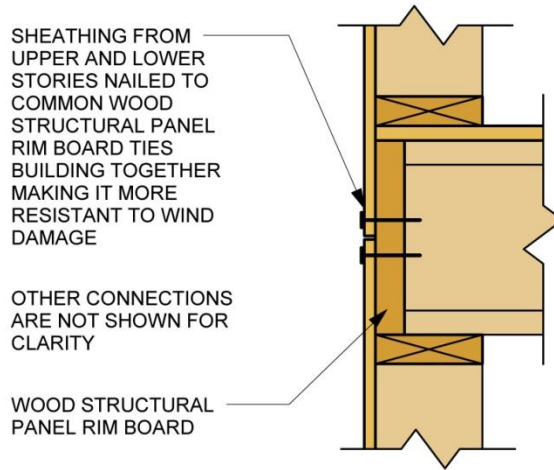

Figure AU402.2.5^b
Sheathing Attachment at Elevated Floor Level Detail

NAIL WALL SHEATHING WITH 8d COMMON (0.131" X 2-1/2") NAILS AT 4" ON CENTER IN THE BOUNDARY OF WOOD STRUCTURAL PANEL WALLSHEATHING AND 6" ON CENTER IN THE INTERMEDIATE STUDS

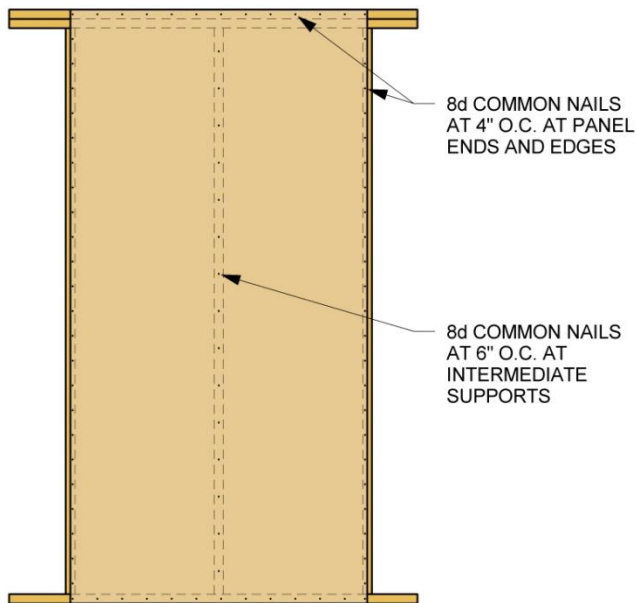

Figure AU402.2.6a^b
Wall Sheathing Attachment Detail

WOOD STRUCTURAL PANEL FLAT-WISE BLOCKING DETAIL

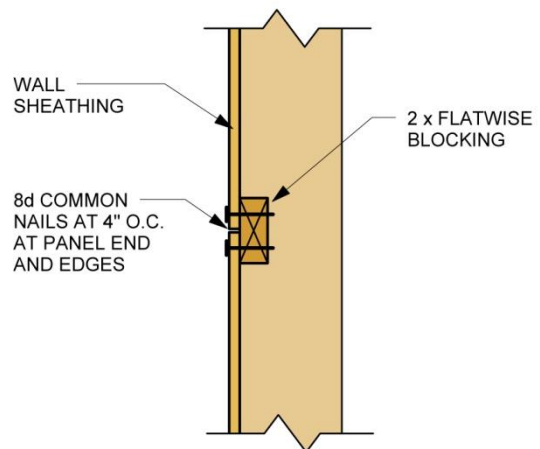

Figure AU402.2.6b
Panel Splice Detail

EXTEND WOOD STRUCTURAL PANEL SHEATHING AT BOTTOM WALL TO SILL PLATE INTERSECTION

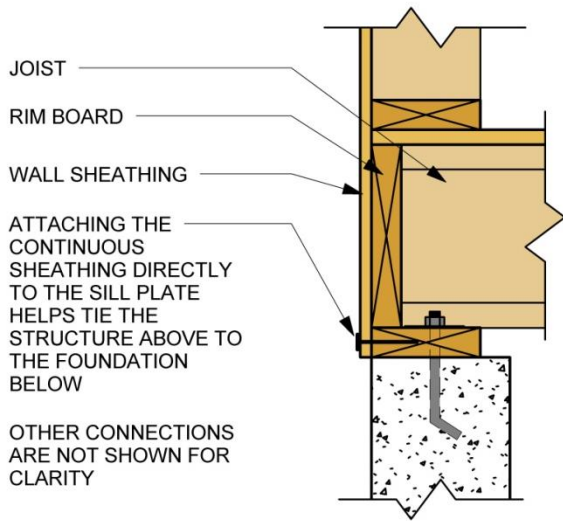

Figure AU402.2.8^b

Wall Sheathing to Sill Plate Connection Detail

SPACE 1/2" ANCHOR BOLTS 48" ON CENTER WITH 0.229" X 3" X 3" SLOTTED SQUARE PLATE WASHERS AT THE WALL TO SILL PLATE INTERSECTION

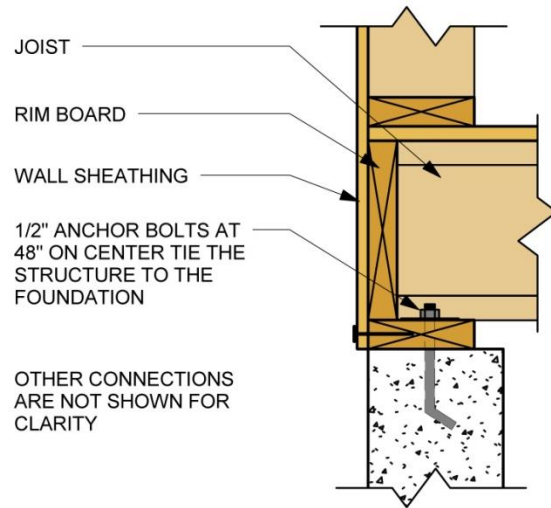

Figure AU402.2.9^b

Anchor Bolt Connection Detail

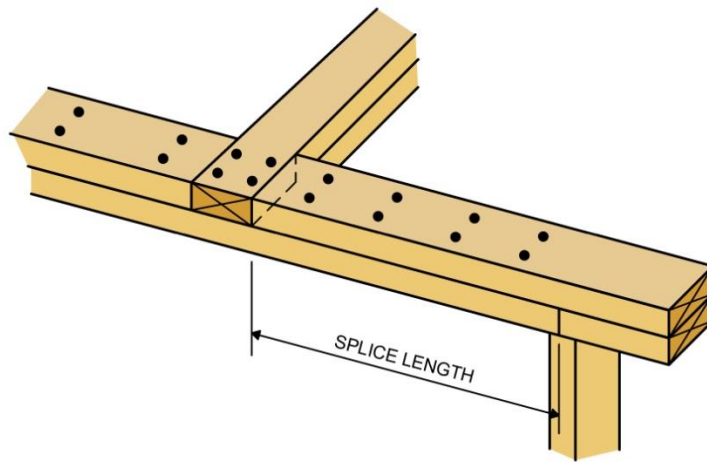

Figure AU402.2.10^c

Top Plate Intersection Detail

(b) *Form No. M310B* August 2011 APA – The Engineered Wood Association

(c) *WFCM Guide to Wood Construction in High Wind Areas for One- and Two-Family Dwellings* – American Forest & Paper Association and the American Wood Council

SECTION AU403

OPTION B –MINIMUM WIND SPEED 110 MPH

AU403.1 Wind speed. Buildings shall be designed and constructed to comply with minimum wind speed of 110 mph Exposure B.

AU403.1.1 Design methods. The design of buildings for wind loads shall be in accordance with one or more of the following methods:

1. AF&PA *Wood Frame Construction Manual* (WFCM); or
2. ICC *Standard for Residential Construction in High-Wind Regions* (ICC 600); or
3. ASCE *Minimum Design Loads for Buildings and Other Structures* (ASCE 7); or
4. AISI *Standard for Cold-Formed Steel Framing – Prescriptive Method For One- and Two-Family Dwellings* (AISI S230); or
5. *International Building Code*; or
6. *Concrete walls in accordance with R404 and R608 of the International Residential Code*; or
7. *Walls of structural insulated panels in accordance with R610 of the International Residential Code*.

SECTION AU404

OPTION C –MINIMUM WIND SPEED 120 MPH

AU404.1 Wind speed. Buildings shall be designed and constructed to comply with minimum wind speed of 120 mph Exposure B.

AU404.1.1 Design methods. The design of buildings for wind loads shall be in accordance with one or more of the following methods:

1. AF&PA *Wood Frame Construction Manual* (WFCM); or
2. ICC *Standard for Residential Construction in High-Wind Regions* (ICC 600); or
3. ASCE *Minimum Design Loads for Buildings and Other Structures* (ASCE 7); or
4. AISI *Standard for Cold-Formed Steel Framing – Prescriptive Method For One- and Two-Family Dwellings* (AISI S230); or
5. *International Building Code*; or
6. *Concrete walls in accordance with R404 and R608 of the International Residential Code*; or
7. *Walls of structural insulated panels in accordance with R610 of the International Residential Code*.

SECTION AU405

OPTION D – MINIMUM WIND SPEED 130 MPH

AU405.1 Wind speed. Buildings shall be designed and constructed to comply with minimum wind speed of 130 mph Exposure B.

AU405.1.1 Design methods. The design of buildings for wind loads shall be in accordance with one or more of the following methods:

1. AF&PA *Wood Frame Construction Manual* (WFCM); or
2. ICC *Standard for Residential Construction in High-Wind Regions* (ICC 600); or
3. ASCE *Minimum Design Loads for Buildings and Other Structures* (ASCE 7); or
4. AISI *Standard for Cold-Formed Steel Framing – Prescriptive Method For One- and Two-Family Dwellings* (AISI S230); or
5. *International Building Code*; or
6. *Concrete walls in accordance with R404 and R608 of the International Residential Code*.

SECTION AU406

FASTENERS AND CONNECTORS FOR CLADDING

AU406.1 Fasteners and connectors for cladding. Fasteners and connectors to be made of stainless steel, hot-dipped zinc-coated galvanized steel, mechanically deposited-zinc coated, silicon bronze or copper. Copper fasteners shall not be permitted for use in conjunction with steel.

SECTION AU407

FENESTRATION

AU407.1 Design pressure. Exterior windows and doors shall be designed to resist the design wind loads specified in *International Residential Code* Table R301.2(2) adjusted for height and exposure per *International Residential Code* Table R301.2(3) based on the minimum wind speed specified in this appendix by the local jurisdiction.

AU407.2 Anchorage methods. Window and door assembly anchoring systems shall be in accordance with the manufacturer's published recommendations to achieve the design pressure specified per Section AU407.1. Substitute anchoring systems shall provide equal or greater anchoring performance as demonstrated by accepted engineering practice. Anchorage shall not exceed the spacing for the tested rated performance.

SECTION AU408 ROOFING

AU408.1 Secondary water barrier. Underlayment shall be two layers applied in the following manner:

- (a) **Self-adhering tape as first layer.** Install minimum 4 inch wide self-adhering modified bitumen tape over sheathing joints. Seal deck penetrations with self-adhering modified bitumen tape. **ASTM D 226 Type I, ASTM D 4869 Type I or ASTM D 6757** as second layer. Apply a 19-inch strip of underlayment felt parallel to and starting at eaves, secure with low-profile, capped-head nails or thin metal disks attached with roofing nails. Fasten at approximately 6 inches on center along the laps and at approximately 12 inches on center along a row in the field of the sheet between the side laps. All laps shall be a minimum of 4 inches. Starting at the eave, apply 36-inch-wide sheets of underlayment, overlapping successive sheets 19 inches, fasten as before. Distortions in the underlayment shall not interfere with the ability of the shingles to seal.
- (b) **Two layers of ASTM D 226 Type I, ASTM D 4869 Type I or ASTM D 6757.** For each layer, apply a 19-inch strip of underlayment felt parallel to and starting at eaves, secure with low-profile, capped-head nails or thin metal disks attached with roofing nails. Fasten at approximately 6 inches on center along the laps and at approximately 12 inches on center along a row in the field of the sheet between the side laps. All laps shall be a minimum of 4 inches. Starting at the eave, apply 36-inch-wide sheets of underlayment, overlapping successive sheets 19 inches, fasten as before. Distortions in the underlayment shall not interfere with the ability of the shingles to seal.

Exception: As an alternative, adhered underlayment complying with ASTM D 1970 shall be permitted.

AU408.2 Fasteners.

AU408.2.1 Underlayment fasteners. Underlayment shall be attached using metal or plastic cap corrosion-resistant nails with a head diameter of not less than 1 inch with a thickness of at least 32-gauge sheet metal. The cap-nail shank shall be a minimum of 12 gauge with a sufficient length to penetrate through the roof sheathing or a minimum of $\frac{3}{4}$ inch into the roof sheathing.

AU408.2.2 Asphalt shingles fasteners. Where asphalt shingles shall be applied with corrosion-resistant nails with shanks made of minimum 12 gauge wire and a minimum head diameter of $\frac{3}{8}$ inch. Nails shall be long enough to penetrate $\frac{3}{4}$ inch into the roof deck. Where the deck is less than $\frac{3}{4}$ inch thick, the nails shall be long enough to penetrate completely through plywood decking and extend at least $\frac{1}{8}$ inch through the roof deck.

AU408.3 Attachment. Where asphalt shingles shall have a minimum number of fasteners required by the manufacturer, but not less than six fasteners per strip shingle or three fasteners per individual shingle. Drive nail head flush with the shingle surface per figure AU408.2.

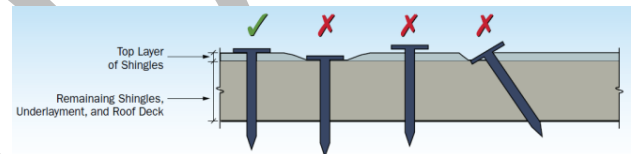

Figure AU408.2^d

(d) FEMA Home Builder's Guide to Coastal Construction Technical Fact Sheet No. 7.3 Asphalt Shingle Roofing for High Wind Regions.

CHAPTER AU5
RESIDENTIAL STORM SHELTERS AND SAFE ROOMS

SECTION AU501

GENERAL

AU501.1 General. This section applies to the construction of residential storm shelters and safe rooms when constructed as separate detached buildings or as internal areas within buildings for the purpose of providing safe refuge for storms that produce high winds, such as tornados and hurricanes. Residential storm shelters or safe rooms shall be offered as an optional package.

SECTION AU502

RESIDENTIAL STORM SHELTERS AND SAFE ROOMS

AU502.1 Residential storm shelters. Residential storm shelters when constructed shall be in compliance with the following:

1. *ICC/NSSA-500* per IRC Section R323.

AU502.2 Residential safe rooms. Residential safe rooms when constructed shall be in compliance with the following:

1. *FEMA 361 Design and Construction Guidance for Community Safe Rooms*; or
2. *FEMA 320 Taking Shelter from the Storm: Building a Safe Room For Your Home and Small Business*

PROPOSED

CHAPTER AU6 RESOURCES

SECTION AU601 CONTACTS

Georgia Department of Community Affairs (DCA) Construction Codes

Georgia State Amendments to the State Minimum
Standard Codes

<https://dca.ga.gov/local-government-assistance/construction-codes-industrialized-buildings/construction-codes>

Phone: 404-679-3118

Georgia Department of Natural Resources (DNR) Floodplain Management

4220 International Parkway, Ste. 101

Atlanta, GA 30354-3902

www.georgiadfirm.com

Phone: 404-675-1757

Federal Emergency Management Agency (FEMA)

www.fema.gov; www.floodsmart.gov

www.fema.gov/rebuild/buildingscience/

FEMA Publications and Technical Bulletins:

www.fema.gov/library/index.jsp

www.fema.gov/plan/prevent/floodplain/techbul.shtm

Georgia Emergency Management Agency (GEMA)

Georgia Office of Homeland Security

P.O. Box 18055

Atlanta, GA 30316-0055

www.gema.ga.gov

www.ready.ga.gov

Phone: 404-635-7000

Georgia Association of Regional Commissions (GARC)

www.garc.ga.gov

<http://garc.ga.gov/main.php?Regional-Commissions-2>

(for assistance in identifying Flood Hazard Areas)

International Code Council (ICC)

www.iccsafe.org

National Weather Service

www.srh.weather.gov

State Fire Marshal's Office

2 Martin Luther King Jr. Drive

Suite 920 / West Tower

Atlanta, Georgia 30334

www.oci.ga.gov

Phone: 404-656-7087

SECTION AU602

EMERGENCY INSPECTION KIT^e

- Staff's disaster response management plan
- Team contact list
- Area maps
- Official identification
- Personal identification
- Inspection forms and placards
- Communication equipment
- Clipboard
- Hard hat
- Orange safety vest
- Dust mask
- Work gloves
- Steel toe and waterproof boots
- Whistle
- First aid kit
- Latex gloves
- Safety glasses
- Sunglasses
- Pocket knife
- Matches
- Antibacterial hand wipes or alcohol-based hand sanitizer
- Insect repellent (w/ Deet or Picaridin)
- Sunscreen (SPF 15 or greater)
- Camera
- Black markers
- Pens & pencils
- Envelope for expense receipts
- Compass, GPS unit
- Backpack, waistpack
- Flashlight and extra batteries
- Battery-operated radio
- Duct tape
- Staples & stapler
- Staple gun
- Calculator
- Tire repair kit

Remember to grab:

- Personal identification
- Rain gear, extra clothing
- Water bottle
- Prescription medication
- Cell phone and charger
- Cash for personal expenses
- Toiletries

SECTION AU603

SAFETY TIPS ^a

1. Always travel in teams of at least two people.
2. Always wear a hard hat, gloves, goggles, safety vest, and dust masks.
3. Always wear safety shoes capable of protecting the toes and bottom of the foot.
4. Survey the building exterior completely before entering.
5. Enter building only if authorized and if deemed safe to do so.
6. Be alert for falling objects.
7. In case of fire, injuries or victims, evacuate the area and alert the fire department immediately.
8. Avoid downed power lines and buildings under them or water surrounding them.
9. In case of gas leaks, shut off the gas (if possible) and report the leak.
10. In a flood situation, have a “walking stick.”

(a) *When Disaster Strikes* by the International Code Council, Inc., Seventh Printing: November 2011, copyright 2007

SECTION AU604

MAJOR DISASTER PROCESS

(from link <http://www.fema.gov/hazard/dproc.shtm>)

A Major Disaster Declaration usually follows these steps:

- **Incident occurs and local government responds**, supplemented by neighboring communities and volunteer agencies. If overwhelmed, turn to the state for assistance;

Generally the local government will issue a local state of emergency

- **The State responds** with state resources, such as the National Guard and state agencies;

Prior to committing state resources, the Governor will declare a state of emergency in the counties impacted by the event for which assistance is needed.

- **Damage assessment** by local, state, federal, and volunteer organizations determine losses and recovery needs;

Generally the locals will submit a preliminary damage assessment to the State and the State will review and determine if state and/or federal assistance is needed. If federal assistance is needed, the state will request FEMA perform a preliminary joint damage assessment. If the Governor determines that the incident is of such severity and magnitude that effective response is beyond the capabilities of the State and the affected local governments then supplementary Federal assistance is requested (next step).

- **A Major Disaster Declaration** is requested by the Governor, based on the damage assessment, and agreement to commit state funds and resources to the long-term recovery;
- **FEMA evaluates** the request and recommends action to the White House based on the disaster, the local community and the state’s ability to recover;
- **The President approves** the request or FEMA informs the Governor it has been denied. This decision process could take a few hours or several weeks depending on the nature of the disaster.

SECTION AU605

SAMPLE EVALUATION FORMS AND INSPECTION PLACARDS ^e (following pages)

Figure AU605.1 e

ATC-45 Rapid Evaluation Safety Assessment Form

Inspection
 Inspector ID: _____ Inspection date: _____
 Affiliation: _____ Inspection time: _____ AM PM
 Areas inspected: Exterior only Exterior and interior

Building Description

Building name: _____ Type of Building
 Address: _____ Mid-rise or high-rise Pre-fabricated
 _____ Low-rise multi-family One- or two-family dwelling
 _____ Low-rise commercial

Building contact/phone: _____ Primary Occupancy
 Number of stories: _____ Dwelling Commercial Government
 "Footprint area" (square feet): _____ Other residential Offices Historic
 Number of residential units: _____ Public assembly Industrial School
 _____ Emergency services Other: _____

Evaluation
 Investigate the building for the conditions below and check the appropriate column. **Estimated Building Damage**
(excluding contents)

Observed Conditions:	Minor/None	Moderate	Severe	
Collapse, partial collapse, or building off foundation	<input type="checkbox"/>	<input type="checkbox"/>	<input type="checkbox"/>	<input type="checkbox"/> None
Building significantly out of plumb or in danger	<input type="checkbox"/>	<input type="checkbox"/>	<input type="checkbox"/>	<input type="checkbox"/> > 0 to < 1%
Damage to primary structural members, racking of walls	<input type="checkbox"/>	<input type="checkbox"/>	<input type="checkbox"/>	<input type="checkbox"/> 1 to < 10%
Falling hazard due to nonstructural damage	<input type="checkbox"/>	<input type="checkbox"/>	<input type="checkbox"/>	<input type="checkbox"/> 10 to < 30%
Geotechnical hazard, scour, erosion, slope failure, etc.	<input type="checkbox"/>	<input type="checkbox"/>	<input type="checkbox"/>	<input type="checkbox"/> 30 to < 70%
Electrical lines / fixtures submerged / leaning trees	<input type="checkbox"/>	<input type="checkbox"/>	<input type="checkbox"/>	<input type="checkbox"/> 70 to < 100%
Other (specify) _____	<input type="checkbox"/>	<input type="checkbox"/>	<input type="checkbox"/>	<input type="checkbox"/> 100%

See back of form for further comments.

Posting
 Choose a posting based on the evaluation and team judgment. Severe conditions endangering the overall building are grounds for an Unsafe posting. Localized Severe and overall Moderate conditions may allow a Restricted Use posting.

INSPECTED (Green placard) **RESTRICTED USE** (Yellow placard) **UNSAFE** (Red placard)

Record any use and entry restrictions exactly as written on placard: _____

Number of residential units vacated: _____

Further Actions Check the boxes below only if further actions are needed.

Barricades needed in the following areas: _____

Detailed Evaluation recommended: Structural Geotechnical Other: _____

Substantial Damage determination recommended

Other recommendations: _____

See back of form for further comments.

© Copyright 2004-07, Applied Technology Council.
 Permission is granted for unlimited, non-exclusive, non-commercial use and distribution of ATC evaluation forms, provided that this Copyright Notice appears on all copies and the Applied Technology Council name shall not be used in any advertising or publicity of Licensee product. Permission is further subject to the following conditions: (1) Licensee does not reprint, repackage or offer this form for sale or license; and (2) no material gain or financial profit is to be made from any sale or license of this form. Placards may be used without restrictions for their intended use as building postings. All rights not specifically granted to Licensee are herein reserved by ATC.

Figure AU605.2 °

ATC-45 Detailed Evaluation Safety Assessment Form

Inspection

Inspector ID: _____ Inspection date: _____

Affiliation: _____ Inspection time: _____ AM PM

Final Posting
from page 2

Inspected
 Restricted Use
 Unsafe

Building Description

Building name: _____

Address: _____

Building contact/phone: _____

Number of stories: _____

"Footprint area" (square feet): _____

Number of residential units: _____

Type of Building

Mid-rise or High-rise
 Low-rise multi-family
 Low-rise commercial

Pre-fabricated
 One- or two-family dwelling
 Other: _____

Primary Occupancy

Dwelling
 Other residential
 Public assembly
 Emergency services

Commercial
 Offices
 Industrial
 Other: _____

Government
 Historic
 School

Evaluation

Investigate the building for the conditions below and check the appropriate column. There is room on the second page for a sketch.

	Minor/None	Moderate	Severe	Comments
Overall hazards:				
Collapse or partial collapse	<input type="checkbox"/>	<input type="checkbox"/>	<input type="checkbox"/>	_____
Building or story lean or drift	<input type="checkbox"/>	<input type="checkbox"/>	<input type="checkbox"/>	_____
Fractured or displaced foundation	<input type="checkbox"/>	<input type="checkbox"/>	<input type="checkbox"/>	_____
Structural hazards:				
Failure of significant element/connection	<input type="checkbox"/>	<input type="checkbox"/>	<input type="checkbox"/>	_____
Column, pier, or bearing wall	<input type="checkbox"/>	<input type="checkbox"/>	<input type="checkbox"/>	_____
Roof/floor framing or connection	<input type="checkbox"/>	<input type="checkbox"/>	<input type="checkbox"/>	_____
Superstructure/foundation connection	<input type="checkbox"/>	<input type="checkbox"/>	<input type="checkbox"/>	_____
Moment frame	<input type="checkbox"/>	<input type="checkbox"/>	<input type="checkbox"/>	_____
Diaphragm/horizontal bracing	<input type="checkbox"/>	<input type="checkbox"/>	<input type="checkbox"/>	_____
Vertical bracing	<input type="checkbox"/>	<input type="checkbox"/>	<input type="checkbox"/>	_____
Shear wall	<input type="checkbox"/>	<input type="checkbox"/>	<input type="checkbox"/>	_____
Nonstructural hazards:				
Parapets, ornamentation	<input type="checkbox"/>	<input type="checkbox"/>	<input type="checkbox"/>	_____
Canopy	<input type="checkbox"/>	<input type="checkbox"/>	<input type="checkbox"/>	_____
Cladding, glazing	<input type="checkbox"/>	<input type="checkbox"/>	<input type="checkbox"/>	_____
Ceilings, light fixtures	<input type="checkbox"/>	<input type="checkbox"/>	<input type="checkbox"/>	_____
Stairs, exits, access walkways, gratings	<input type="checkbox"/>	<input type="checkbox"/>	<input type="checkbox"/>	_____
Interior walls, partitions	<input type="checkbox"/>	<input type="checkbox"/>	<input type="checkbox"/>	_____
Mechanical & electrical equipment	<input type="checkbox"/>	<input type="checkbox"/>	<input type="checkbox"/>	_____
Elevators	<input type="checkbox"/>	<input type="checkbox"/>	<input type="checkbox"/>	_____
Building contents, other _____	<input type="checkbox"/>	<input type="checkbox"/>	<input type="checkbox"/>	_____
Geotechnical hazards:				
Slope failure, debris impact	<input type="checkbox"/>	<input type="checkbox"/>	<input type="checkbox"/>	_____
Ground movement, erosion, sedimentation	<input type="checkbox"/>	<input type="checkbox"/>	<input type="checkbox"/>	_____
Differential settlement	<input type="checkbox"/>	<input type="checkbox"/>	<input type="checkbox"/>	_____

Continue on page 2

Georgia International Residential Code Appendix U Disaster Resilient Construction

25

INSPECTED

LAWFUL OCCUPANCY PERMITTED

This structure has been inspected (as indicated below) and no apparent structural hazard has been found.

Inspected Exterior Only

Inspected Exterior and Interior

Report any unsafe condition to local authorities; reinspection may be required.

Inspector Comments:

Facility Name and Address:

Date _____

Time _____

This facility was inspected under emergency conditions for:

(Jurisdiction)

Inspector ID / Agency

**Do Not Remove, Alter, or Cover this Placard
until Authorized by Governing Authority**

RESTRICTED USE

Caution: This structure has been inspected and found to be damaged as described below:

Date _____
Time _____

Entry, occupancy, and lawful use are restricted as indicated below:

- Do not enter the following areas: _____
- Brief entry allowed for access to contents: _____
- Other restrictions: _____

Facility name and address:

This facility was inspected under emergency conditions for:

(Jurisdiction)

Inspector ID / Agency

**Do Not Remove, Alter, or Cover this Placard
until Authorized by Governing Authority**

Figure AU605.5 e

UNSAFE

**DO NOT ENTER OR OCCUPY
(THIS PLACARD IS NOT A DEMOLITION ORDER)**

This structure has been inspected, found to be seriously damaged and is unsafe to occupy, as described below:

Do not enter, except as specifically authorized in writing by jurisdiction. Entry may result in death or injury.

Facility Name and Address:

Date _____
Time _____

This facility was inspected under emergency conditions for:

(Jurisdiction)

Inspector ID / Agency

**Do Not Remove, Alter, or Cover this Placard
until Authorized by Governing Authority**

CHAPTER AU7 REFERENCES

REFERENCED STANDARDS

ASCE Standards ASCE/SEI 24-05 Flood Resistant Design and Construction
FEMA P-320, Third Edition / August 2008 Taking Shelter From the Storm: Building a Safe Room For Your Home or Small Business, Includes Construction Plans and Cost Estimates
FEMA 361, Second Edition / August 2008 Design and Construction Guidance for Community Safe Rooms
FEMA Technical Bulletin 2, Table 2. Types, Uses, and Classifications of Materials

REFERENCED RESOURCES

- (a) *When Disaster Strikes* by the International Code Council, Inc., Seventh Printing: November 2011, copyright 2007
- (b) *Form No. M310B* August 2011 APA – The Engineered Wood Association; www.apawood.org
- (c) *WFCM Guide to Wood Construction in High Wind Areas for One- and Two-Family Dwellings* – American Forest & Paper Association and the American Wood Council; www.awc.org
- (d) *FEMA Home Builder's Guide to Coastal Construction Technical Fact Sheet No. 7.3 Asphalt Shingle Roofing for High Wind Regions*.
- (e) *Disaster Mitigation: A Guide for Building Departments* by the International Code Council, Inc., copyright 2009

Index of Figures:

Figure AU103.3	Post Disaster Building Safety Evaluation Chart ^a	10
Figure AU402.2	Prescriptive wood frame construction method deemed to comply with 100 mph	14
Figure AU402.2.1	Roof Sheathing Attachment Detail	15
Figure AU402.2.2	Gable End Wall Connection Detail	15
Figure AU402.2.3	Gable End Wall Sheathing Detail	16
Figure AU402.2.4	Roof Framing to Wall Connection Detail	16
Figure AU402.2.5	Sheathing Attachment at Elevated Floor Level Detail	17
Figure AU402.2.6a	Wall Sheathing Attachment Detail	17
Figure AU402.2.6b	Panel Splice Detail	17
Figure AU402.2.8	Wall Sheathing to Sill Plate Connection Detail	18
Figure AU402.2.9	Anchor Bolt Connection Detail	18
Figure AU402.2.10	Top Plate Intersection Detail	18
Figure AU408.2	Roof Shingle Nailing Detail	20
Figure AU605.1	ATC-45 Rapid Evaluation Form	24
Figure AU605.2	ATC-45 Detail Evaluation Form	25
Figure AU605.3	Inspected Placard	27
Figure AU605.4	Restricted Placard	28
Figure AU605.5	Unsafe Placard	29