

Air Barrier and Insulation Installation Component Guide

| | COMPONENT | AIR BARRIER CRITERIA | INSULATION INSTALLATION CRITERIA |
|----|--|---|---|
| 1 | General requirements | A continuous air barrier shall be installed in the building envelope. The exterior thermal envelope contains a continuous air barrier. Breaks or joints in the air barrier shall be sealed. | Air-permeable insulation shall not be used as a sealing material. |
| 2 | Ceiling/attic | The air barrier in any dropped ceiling/soffit shall be aligned with the insulation and any gaps in the air barrier shall be sealed. Access openings, drop down stairs or knee wall doors to unconditioned attic spaces shall be sealed. | The insulation in any dropped ceiling/soffit shall be aligned with the air barrier. |
| 3 | Walls | The junction of the foundation and sill plate shall be sealed. The junction of the top plate and the top of exterior walls shall be sealed. Knee walls shall be sealed. | Cavities within corners and headers of frame walls shall be insulated by completely filling the cavity with a material having a thermal resistance of R-3 per inch minimum. Exterior thermal envelope insulation for framed walls shall be installed in substantial contact and continuous alignment with the air barrier. |
| 4 | Windows, skylights and doors | The space between window/door jambs and framing, and skylights and framing shall be sealed. | |
| 5 | Rim joists | Rim joists shall include the air barrier. | Rim joists shall be insulated. |
| 6 | Floors (including above garage and cantilevered floors) | The air barrier shall be installed at any exposed edge of insulation. | Floor framing cavity insulation shall be installed to maintain permanent contact with the underside of subfloor decking, or floor framing cavity insulation shall be permitted to be in contact with the top side of sheathing, or continuous insulation installed on the underside of floor framing and extends from the bottom to the top of all perimeter floor framing members. |
| 7 | Crawl space walls | Exposed earth in unvented crawl spaces shall be covered with a Class I vapor retarder with overlapping joints taped. | Where provided instead of floor insulation (unvented crawl spaces), insulation shall be permanently attached to the crawlspace walls. |
| 8 | Shafts, penetrations | Duct shafts, utility penetrations, and flue shafts opening to exterior or unconditioned space shall be sealed. | Capped chases shall be insulated to surrounding ceiling R-values (maintain clearance from combustion flues). |
| 9 | Narrow cavities | | Batts in narrow cavities shall be cut to fit, or narrow cavities shall be filled by insulation that on installation readily conforms to the available cavity space. |
| 10 | Garage separation | Air sealing shall be provided between the garage and conditioned spaces. | Band area shall be blocked, sealed and insulated. |
| 11 | Recessed lighting | Recessed light fixtures installed in the building thermal envelope shall be sealed to the drywall. | Recessed light fixtures installed in the building thermal envelope shall be air tight and IC rated. |
| 12 | Plumbing and wiring | Wiring and plumbing penetrations shall be sealed. | Batt insulation shall be cut neatly to fit around wiring and plumbing in exterior walls, or insulation that on installation readily conforms to available space shall extend behind piping and wiring. |
| 13 | Shower/tub on exterior wall | The air barrier installed at exterior walls adjacent to showers and tubs shall separate them from the showers and tubs. | Exterior walls adjacent to showers and tubs shall be insulated. |
| 14 | Electrical/phone box on exterior walls | The air barrier shall be installed behind electrical or communication boxes or air-sealed boxes shall be installed. | |
| 15 | HVAC register boots | HVAC register boots shall be sealed to the subfloor or drywall. | Boots in unconditioned spaces shall be insulated. Recommend insulating boots in conditioned spaces for condensation control. |
| 16 | Concealed sprinklers | When required to be sealed, concealed fire sprinklers shall only be sealed in a manner that is recommended by the manufacturer. Caulking or other adhesive sealants shall not be used to fill voids between fire sprinkler cover plates and walls or ceilings. | |
| 17 | Blocking between framing (e.g. beneath knee walls, cantilevered floors, garage separation walls) | Blocking shall be sealed to framing. | Insulation shall be in contact with blocking. |
| 18 | Common walls | Air barrier is installed in common wall between dwelling units. | |
| 19 | Fireplaces | New wood-burning fireplaces shall have tight-fitting flue dampers or doors, and outdoor combustion air. | Fireplace chase insulation shall be restrained to stay in place. |

Disclaimer: This document was created by Southface and is intended solely to help graphically demonstrate the air leakage and insulation provisions of the 2015 IECC (2019 Georgia Energy Code). It does not cover all air sealing locations, materials or techniques. Other code provisions may be applicable as well.

Air sealing key points

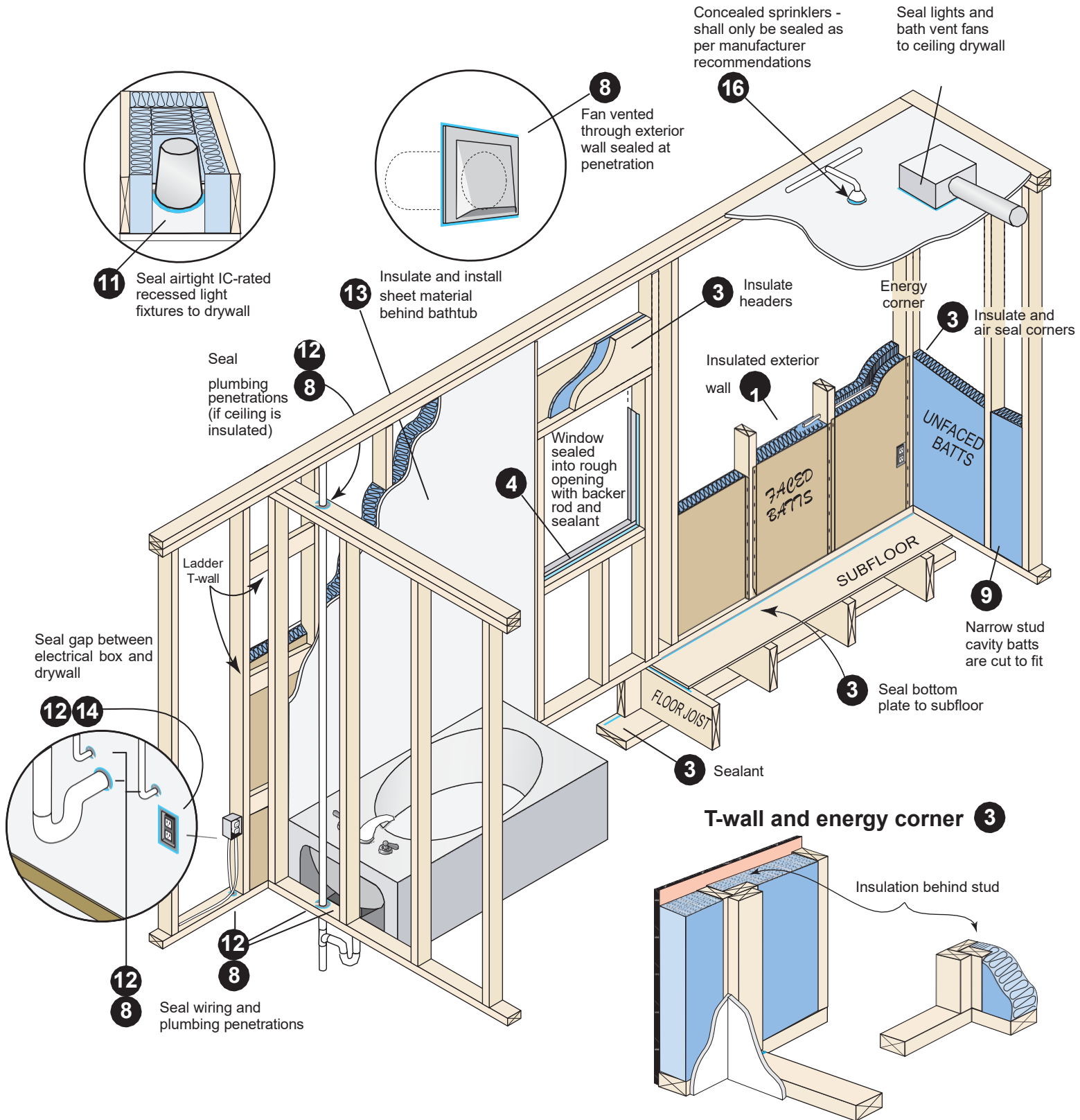

Disclaimer:
 This document was created by Southface and is intended solely to help graphically demonstrate the air leakage and insulation provisions of the 2015 IECC (2019 Georgia Energy Code). It does not cover all air sealing locations, materials or techniques. Other code provisions may be applicable as well.

Air sealing key points *continued*

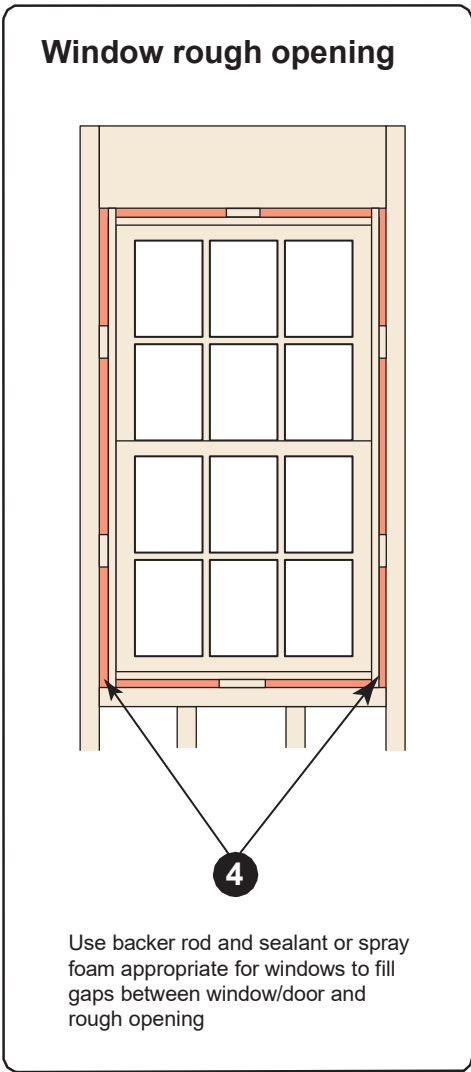

Wall cross-section

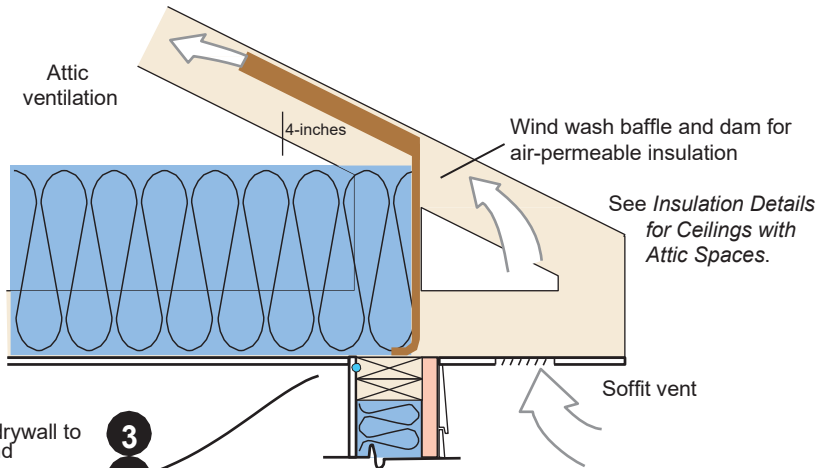

3
1
Seal drywall to top and bottom plates with caulk, gaskets or glue (recommended)

3
Seal bottom plate to subfloor

5
Seal band joist to subfloor and plates

1
Seal drywall to top plate with caulk, gaskets or glue (recommended)

1
Tape or caulk exterior sheathing seams (often the sheathing is the primary air barrier in framed walls)

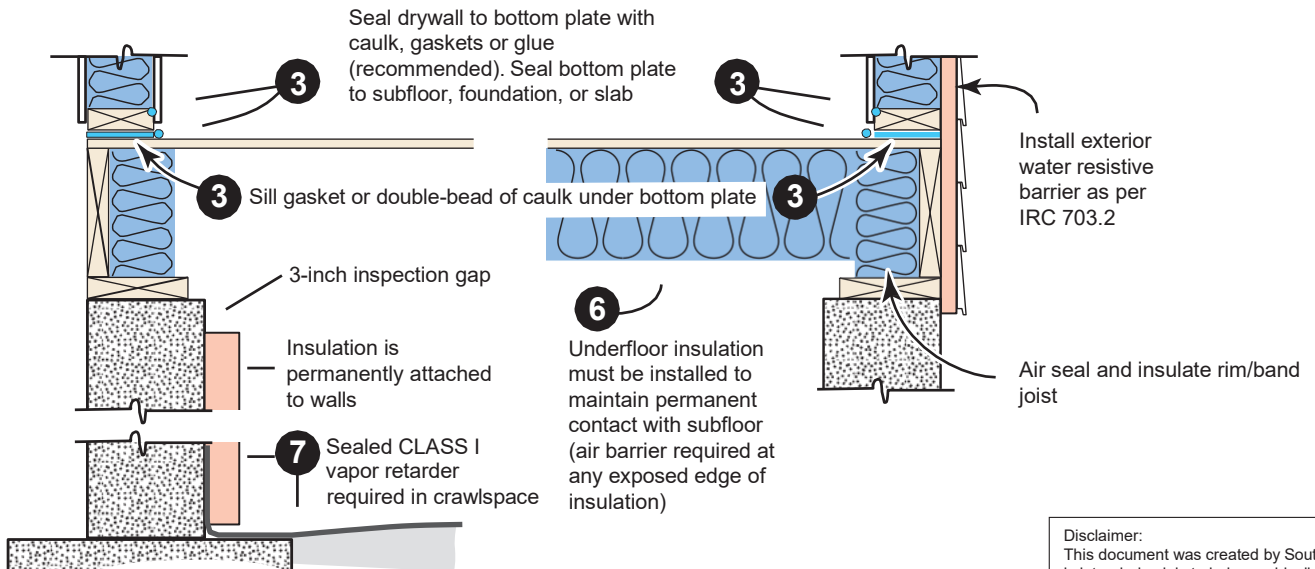

Disclaimer:
 This document was created by Southface and is intended solely to help graphically demonstrate the air leakage and insulation provisions of the 2015 IECC (2019 Georgia Energy Code). It does not cover all air sealing locations, materials or techniques. Other code provisions may be applicable as well.

Air sealing key points *continued*

Combustion chase penetrations

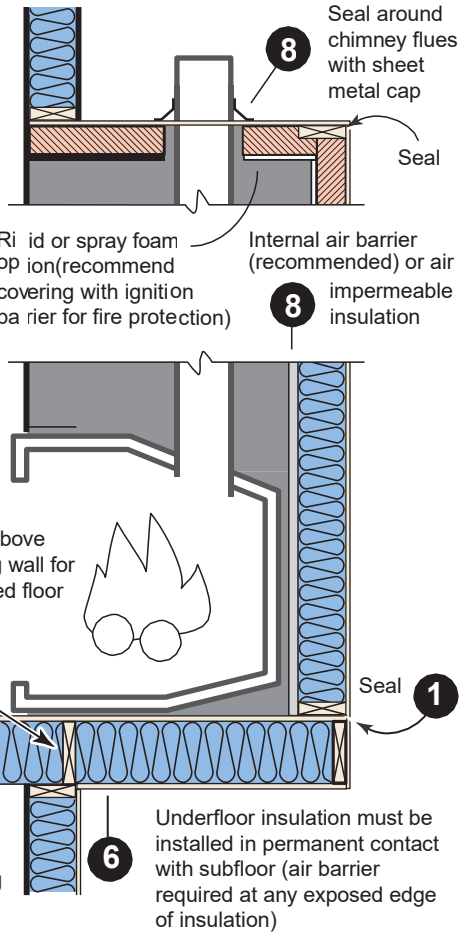

Exterior penetrations

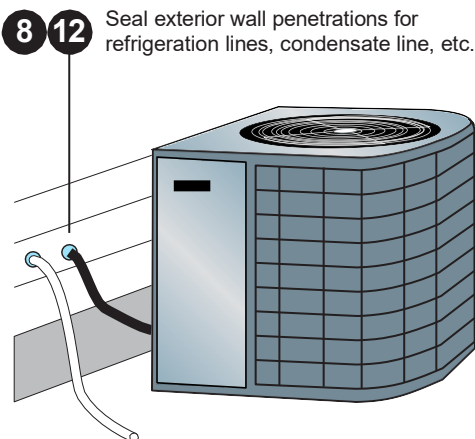

Combustion closet

Combustion air inlets
as per mechanical and/or fuel gas code

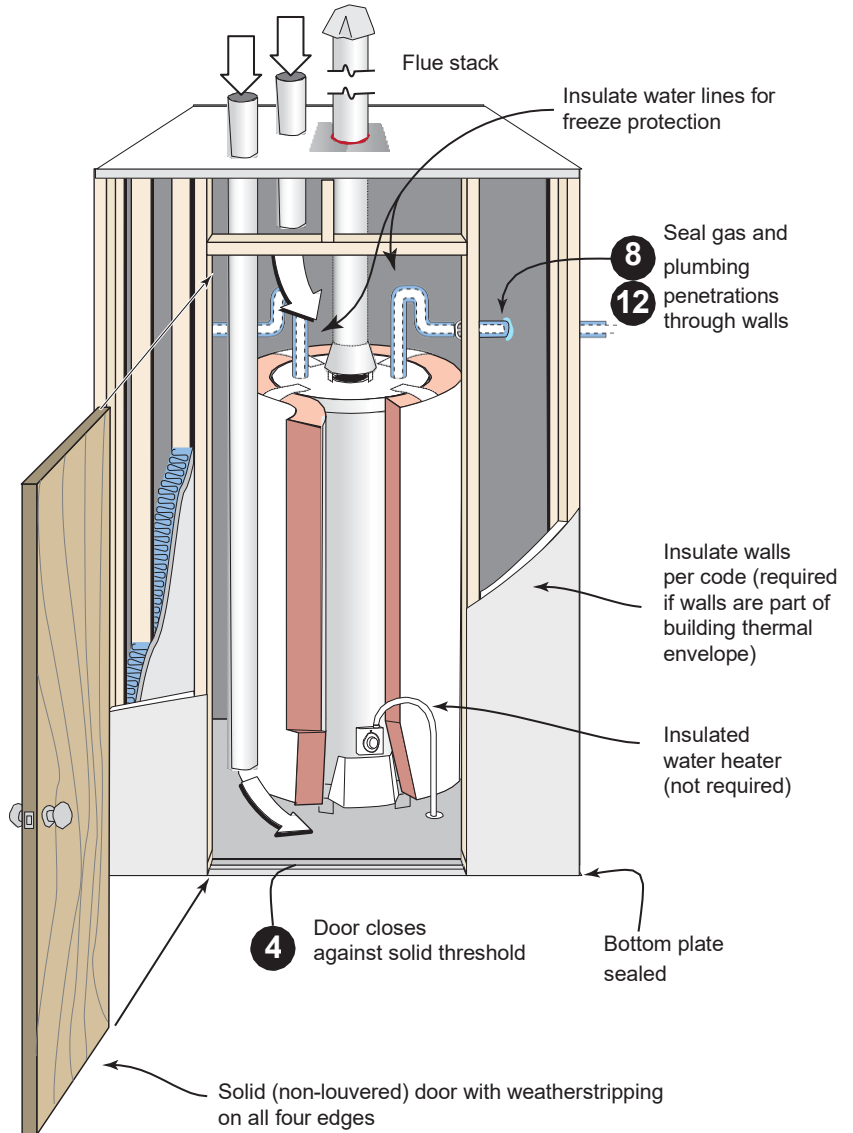

Disclaimer:
This document was created by Southface and is intended solely to help graphically demonstrate the air leakage and insulation provisions of the 2015 IECC (2019 Georgia Energy Code). It does not cover all air sealing locations, materials or techniques. Other code provisions may be applicable as well.

Air sealing key points *continued*

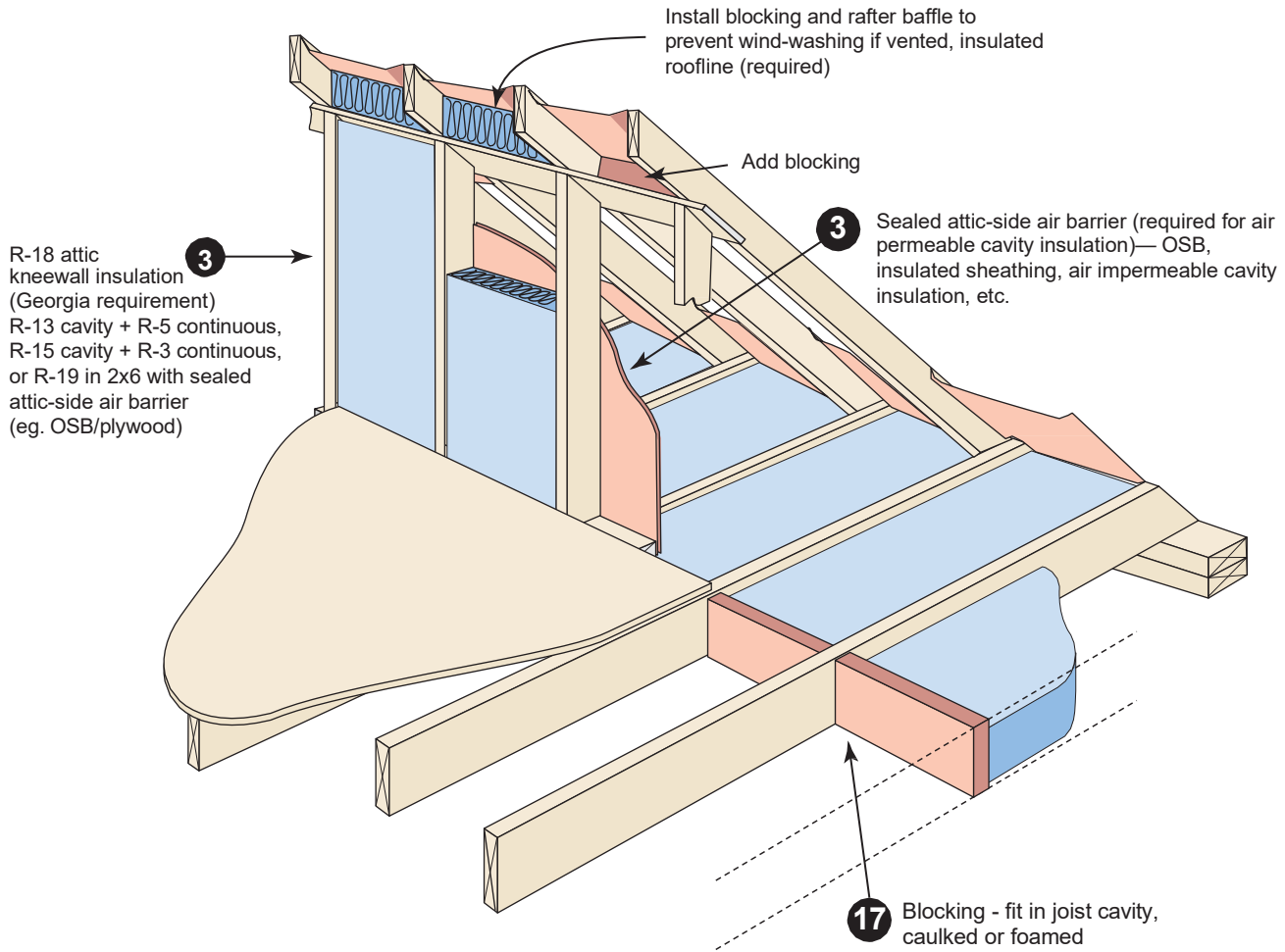

Attic knee-walls

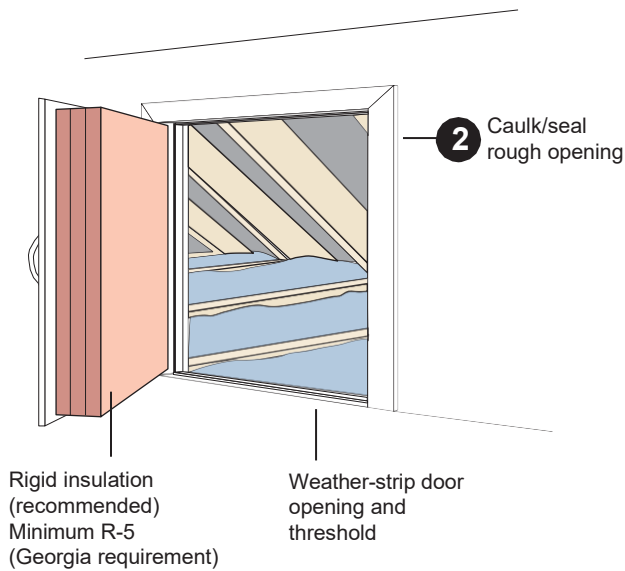

Two-level attic

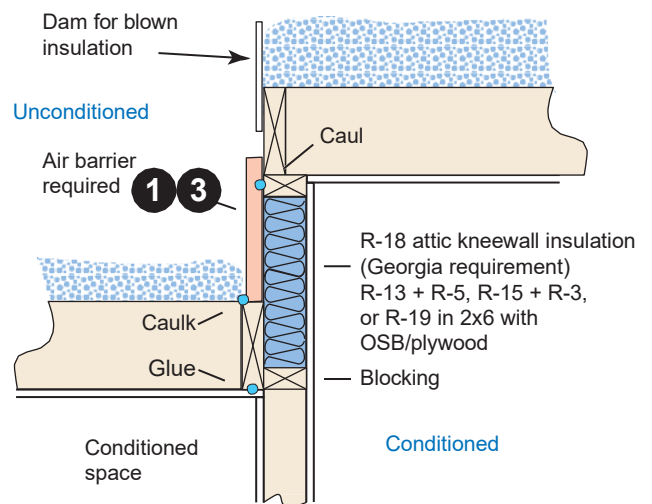

Disclaimer:
This document was created by Southface and is intended solely to help graphically demonstrate the air leakage and insulation provisions of the 2015 IECC (2019 Georgia Energy Code). It does not cover all air sealing locations, materials or techniques. Other code provisions may be applicable as well.

Air sealing key points *continued*

Attic scuttle

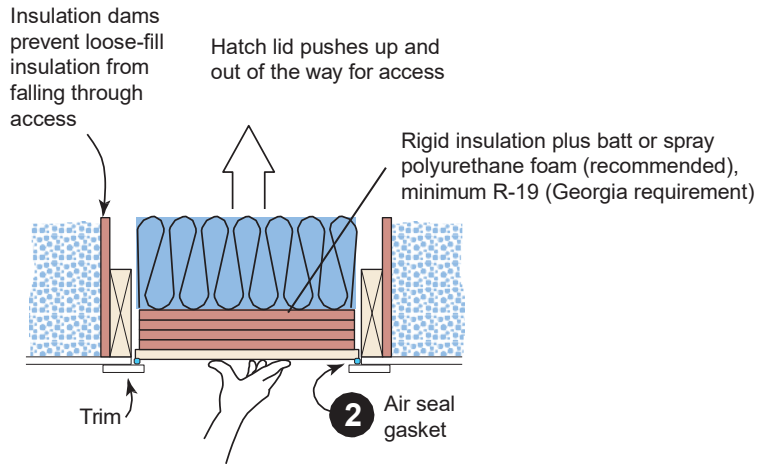

Attic pull-down stairs

Rigid insulation box forms lid for pull-down attic staircase (recommended)

Insulation dams prevent loose-fill insulation from falling through access

Cover box pushes up and out of the way for access

Minimum R-5 (Georgia requirement)

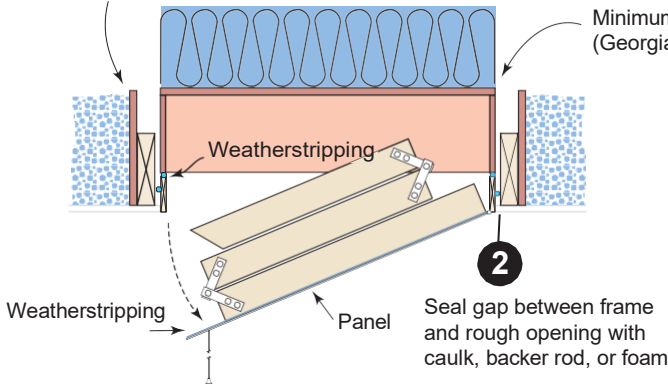

Boxed enclosure for staircase has rigid hinged lid with insulation on top

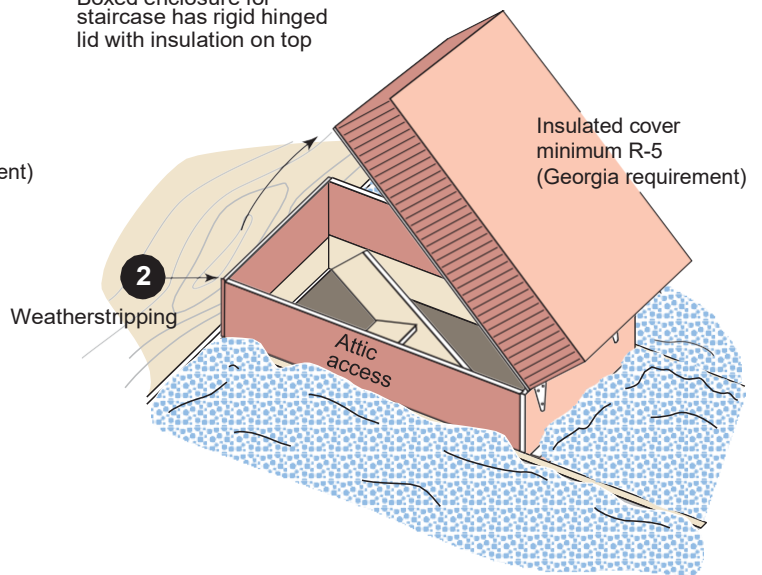

Attic pull-down stairs

Insulation dams prevent loose-fill insulation from falling through access

2 Seal gap between frame and rough opening with caulk, backer rod, or foam

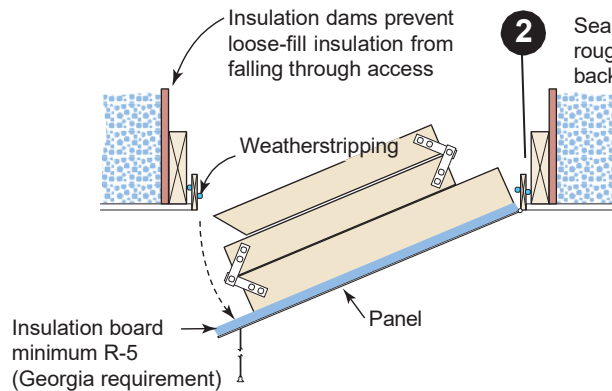

Disclaimer:
This document was created by Southface and is intended solely to help graphically demonstrate the air leakage and insulation provisions of the 2015 IECC (2019 Georgia Energy Code). It does not cover all air sealing locations, materials or techniques. Other code provisions may be applicable as well.

Garage blocking and sealing key points

Blocking, air sealing and insulation required above garage separation wall

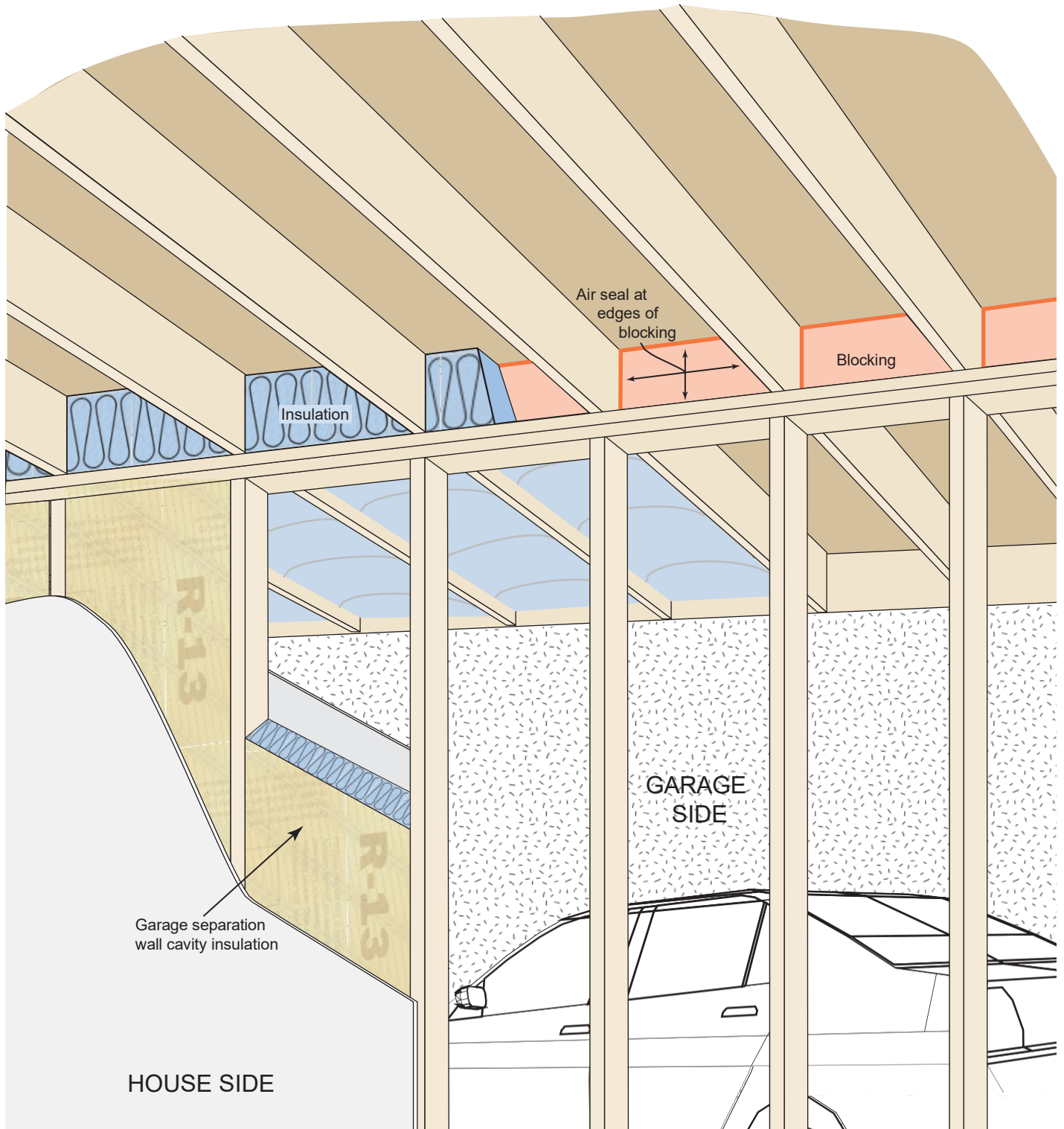

Disclaimer:
This document was created by Southface and is intended solely to help graphically demonstrate the air leakage and insulation provisions of the 2015 IECC (2019 Georgia Energy Code). It does not cover all air sealing locations, materials or techniques. Other code provisions may be applicable as well.

Air sealing key points *continued*

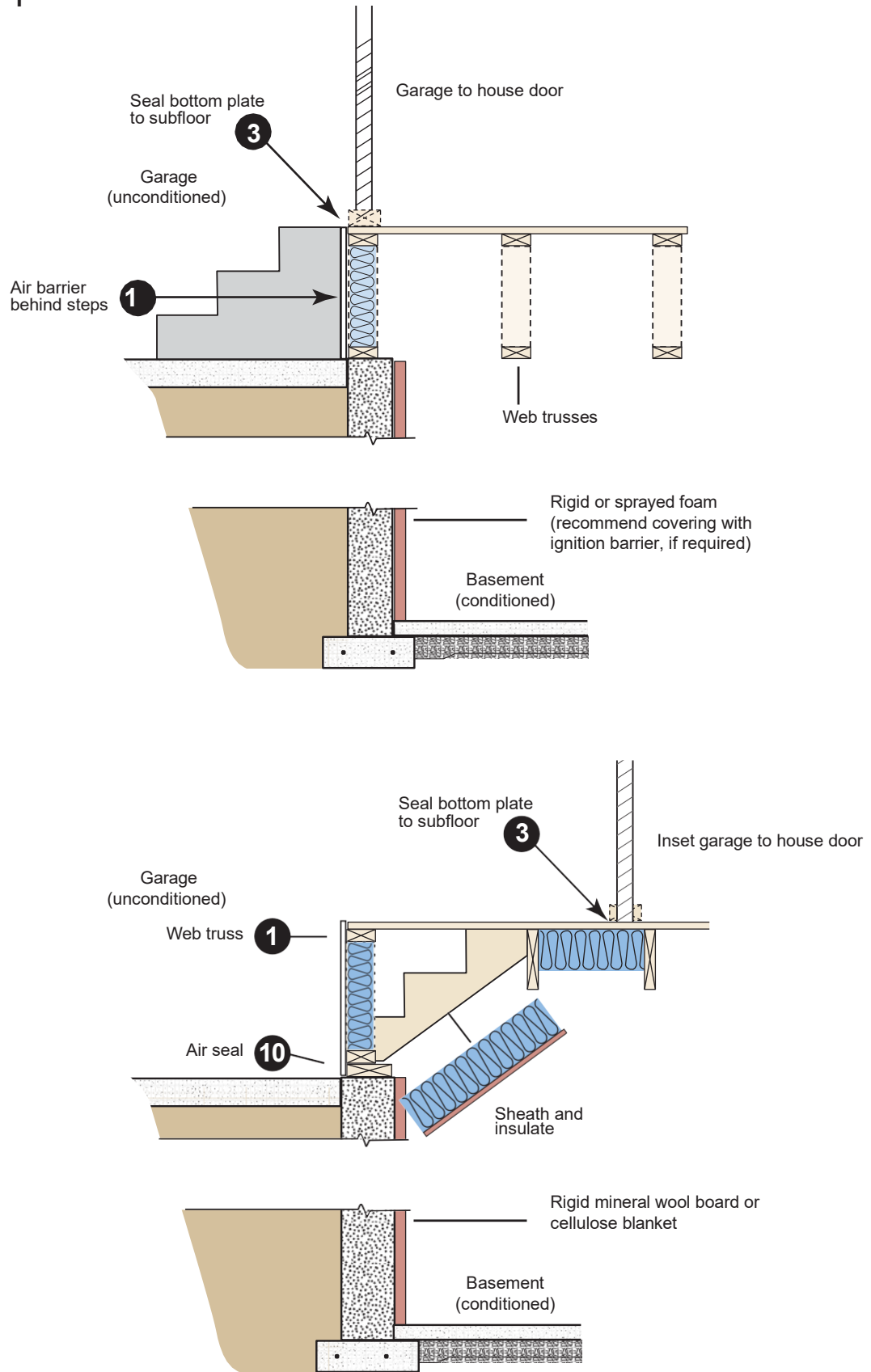

Disclaimer:
This document was created by Southface and is intended solely to help graphically demonstrate the air leakage and insulation provisions of the 2015 IECC (2019 Georgia Energy Code). It does not cover all air sealing locations, materials or techniques. Other code provisions may be applicable as well.

Duct Sealing key points

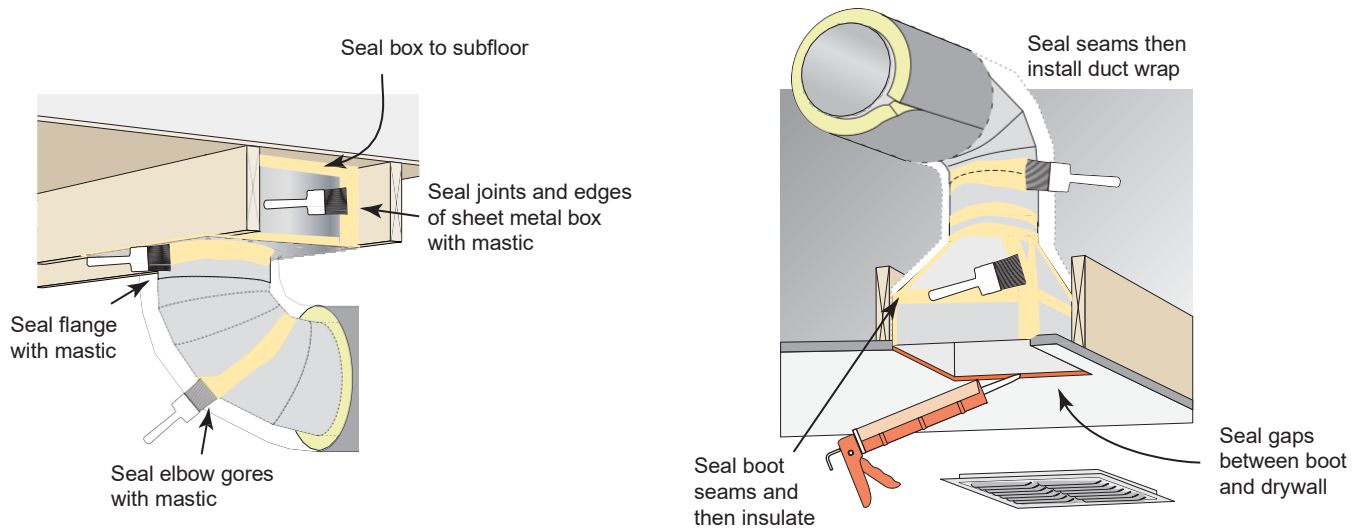
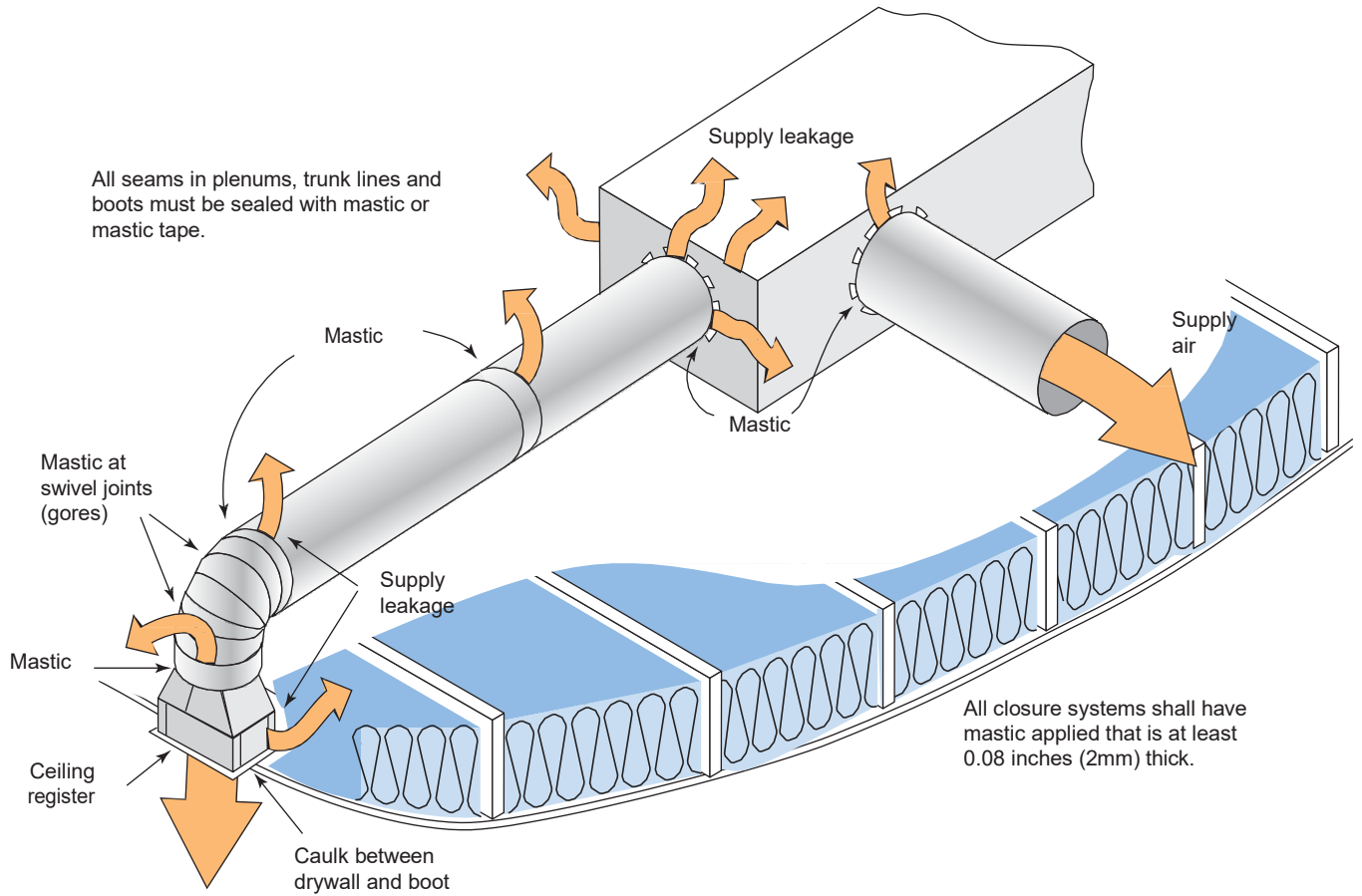

Disclaimer:
 This document was created by Southface and is intended solely to help graphically demonstrate the air leakage and insulation provisions of the 2015 IECC (2019 Georgia Energy Code). It does not cover all air sealing locations, materials or techniques. Other code provisions may be applicable as well.

Air Handler Sealing key points

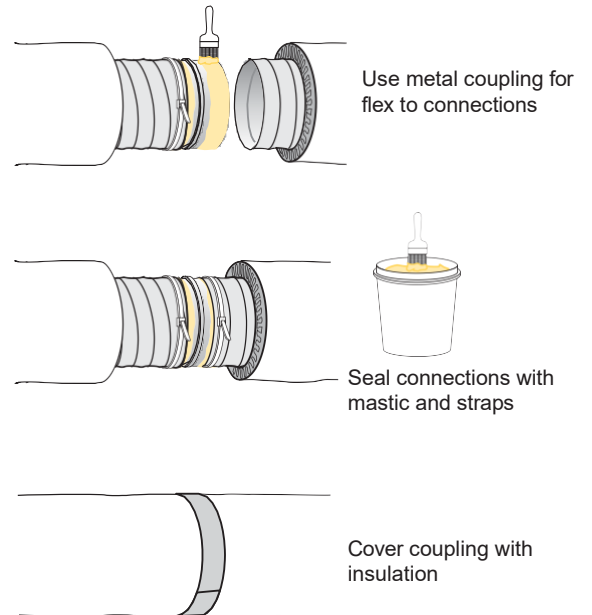
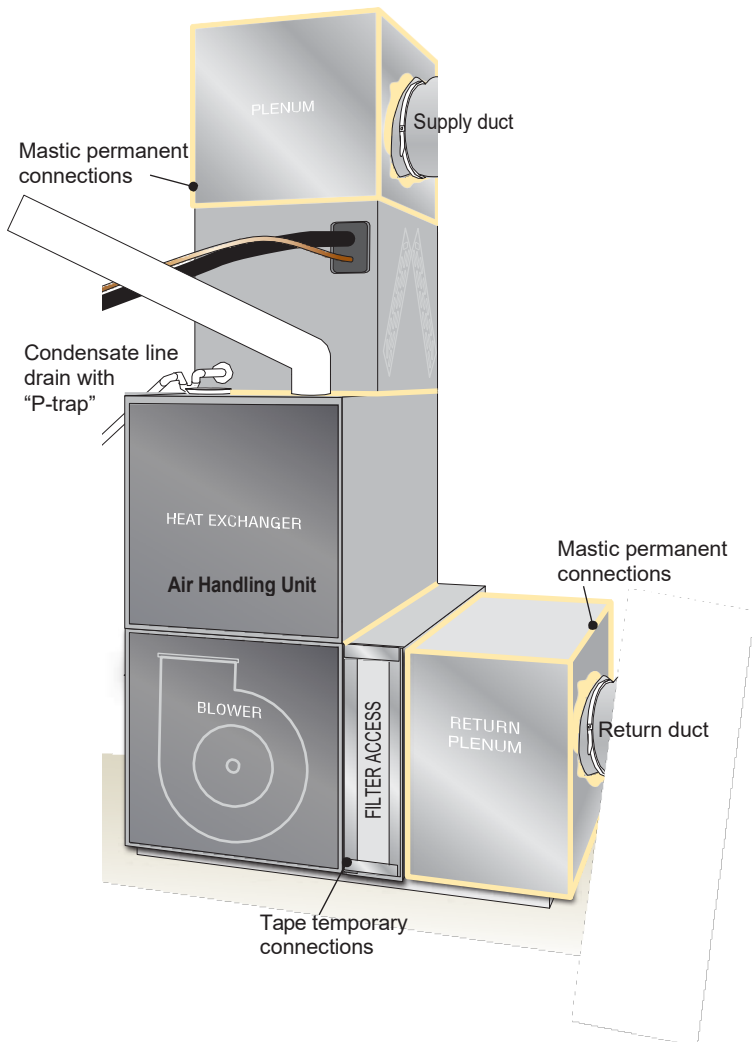
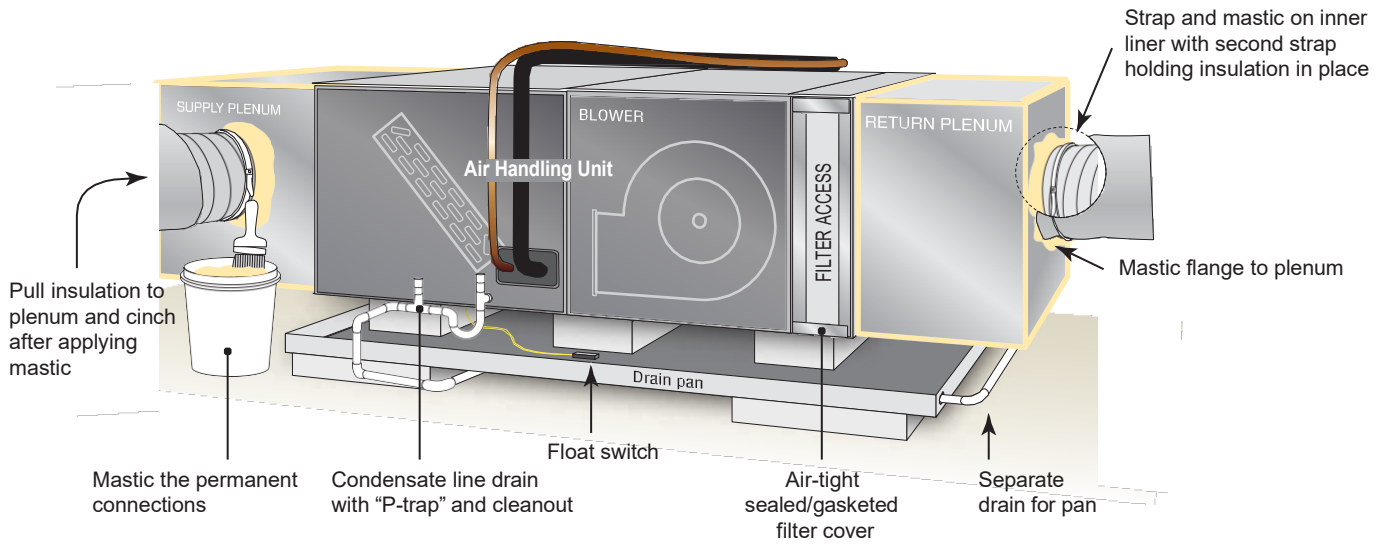

Disclaimer:
 This document was created by Southface and is intended solely to help graphically demonstrate the air leakage and insulation provisions of the 2015 IECC (2019 Georgia Energy Code). It does not cover all air sealing locations, materials or techniques. Other code provisions may be applicable as well.

Air sealing key points *continued*

Multifamily

Multifamily Air-sealing Details

- 8 Cap and seal all chases including chases for grouped utility lines and radon vents

Seal penetrations in mechanical closet including penetrations for the:

- 8 supply plenum
 - 8 outside air ventilation
 - 8 12 refrigerant line
 - 12 plumbing
 - 12 14 electrical
 - 12 gas fuel
- 5 Seal band area at exterior sheathing side and all penetrations through band
 - 1 3 UL-compliant air sealing at drywall finishing for any wall adjacent to stairwell or elevator. Air seal this gap at every change in floor level
 - 8 Seal miscellaneous clustered penetrations through building envelope (e.g. refrigerant lines)

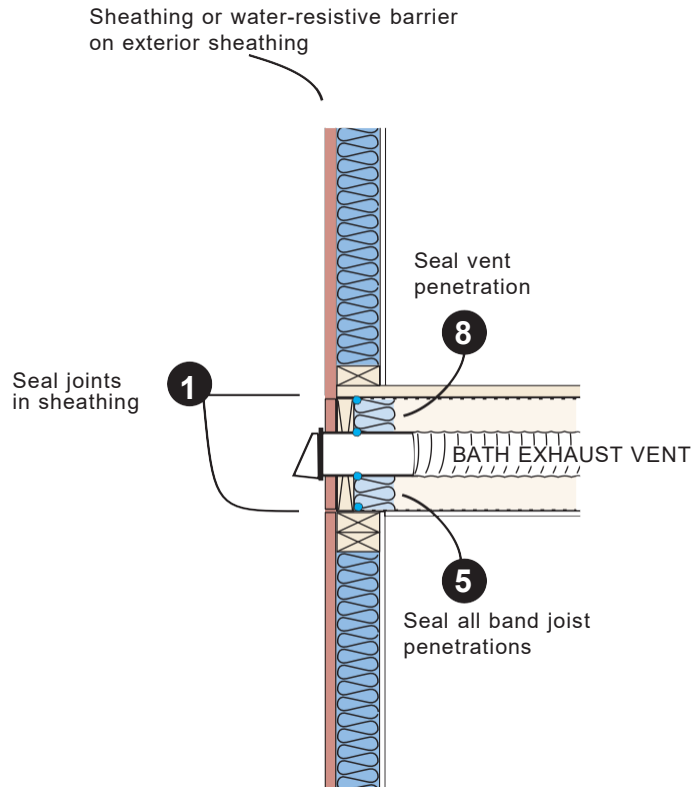

Disclaimer:
This document was created by Southface and is intended solely to help graphically demonstrate the air leakage and insulation provisions of the 2015 IECC (2019 Georgia Energy Code). It does not cover all air sealing locations, materials or techniques. Other code provisions may be applicable as well.

Air sealing key points *continued*

Multifamily

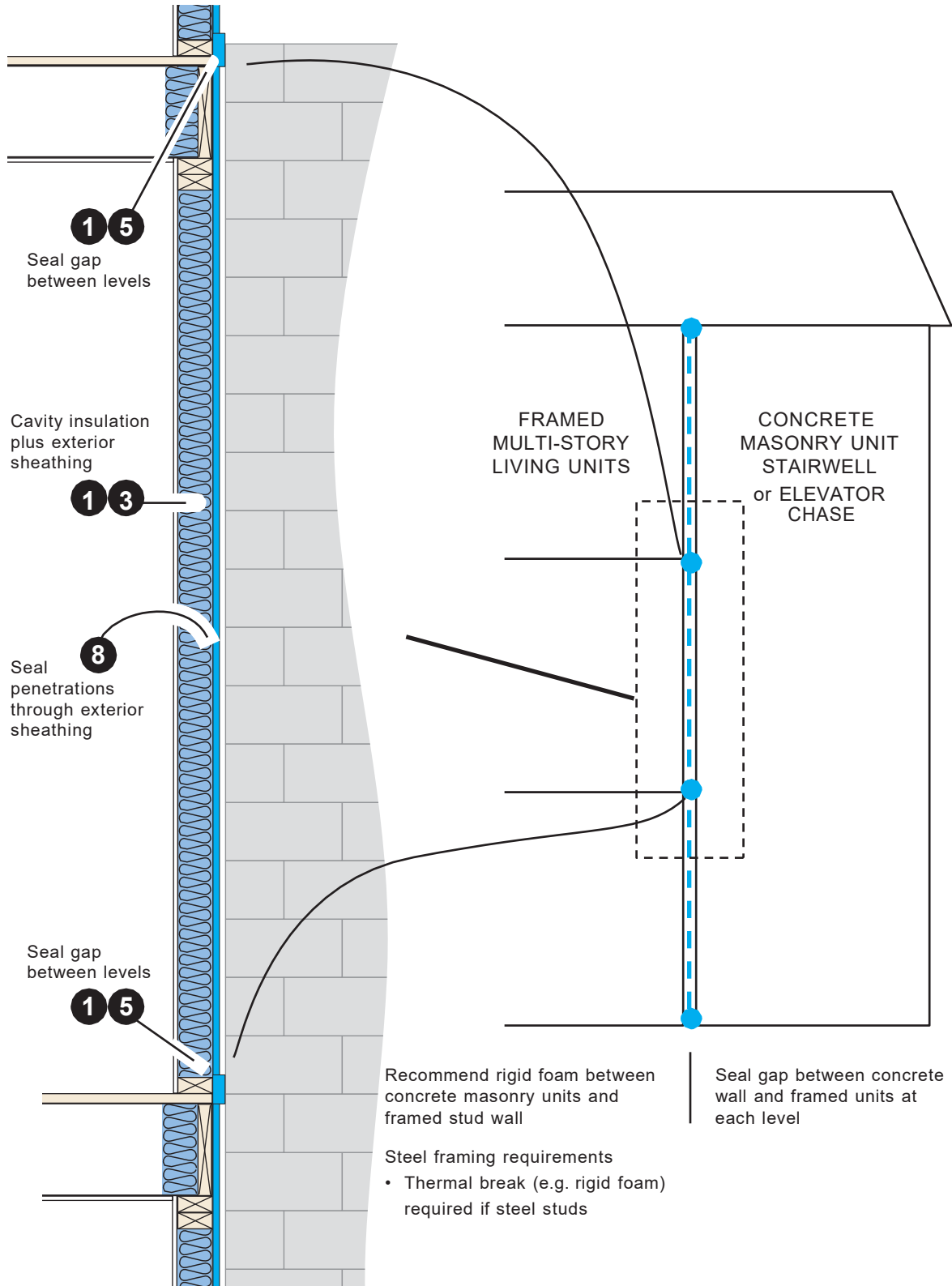

Disclaimer:
This document was created by Southface and is intended solely to help graphically demonstrate the air leakage and insulation provisions of the 2015 IECC (2019 Georgia Energy Code). It does not cover all air sealing locations, materials or techniques. Other code provisions may be applicable as well.

Air sealing key points *continued*

Multifamily Mechanical Closet

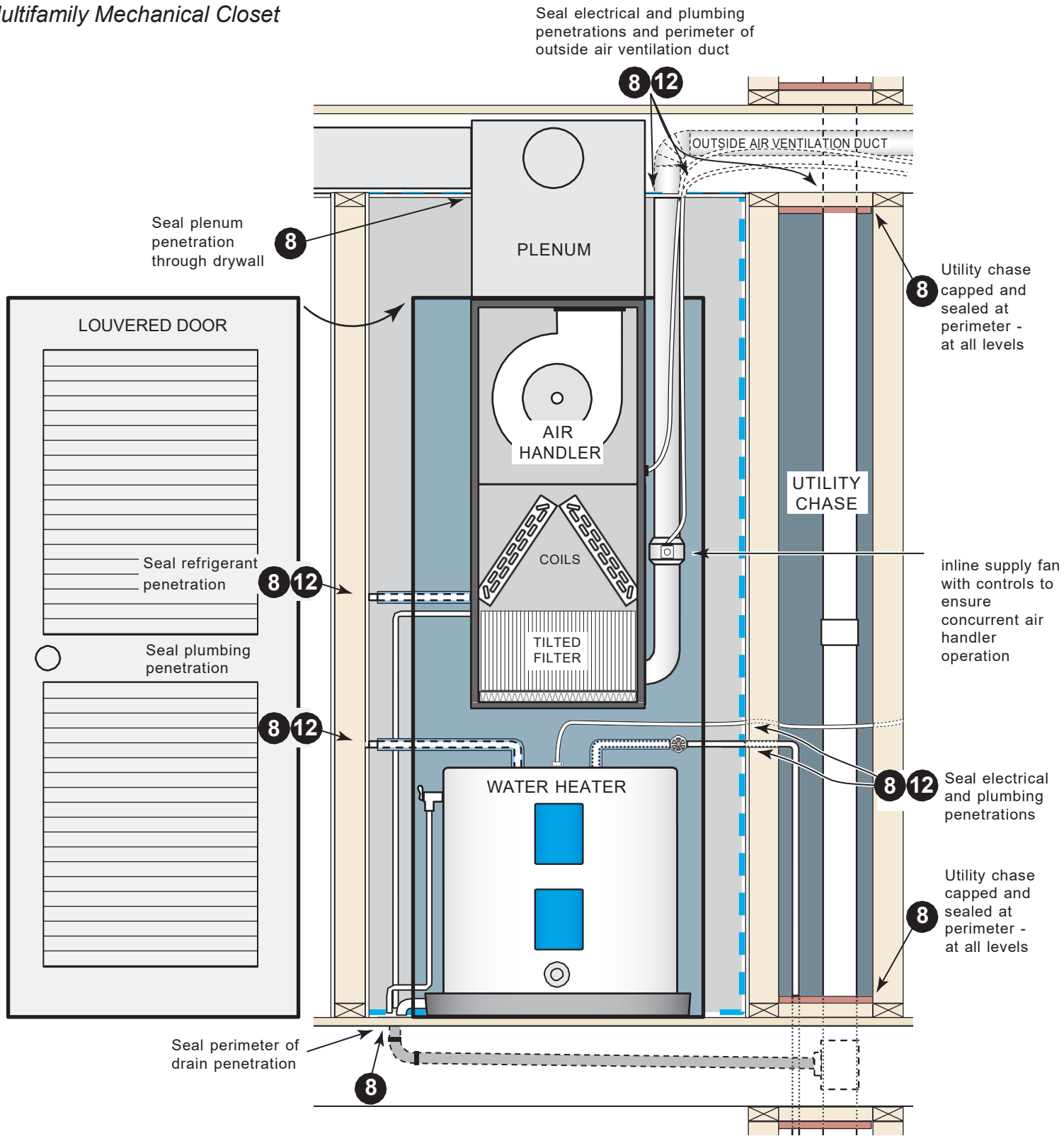

Disclaimer:
 This document was created by Southface and is intended solely to help graphically demonstrate the air leakage and insulation provisions of the 2015 IECC (2019 Georgia Energy Code). It does not cover all air sealing locations, materials or techniques. Other code provisions may be applicable as well.

Building Thermal Envelope

— The basement walls, exterior walls, floor, roof, and any other building element that enclose conditioned space. This boundary also includes the boundary between conditioned space and any exempt or unconditioned space. —2015 IECC

The *building thermal envelope* is the barrier that separates the conditioned space from the outside or unconditioned spaces. The building envelope consists of two parts - an air barrier and a thermal barrier that must be both continuous and contiguous (touching each other). In a typical residence, the building envelope consists of the roof, walls, windows, doors, and foundation. Examples of unconditioned spaces include attics, vented crawlspaces, garages, and basements with ceiling insulation and no HVAC supply registers.

Example 1 – Prescriptive Compliance

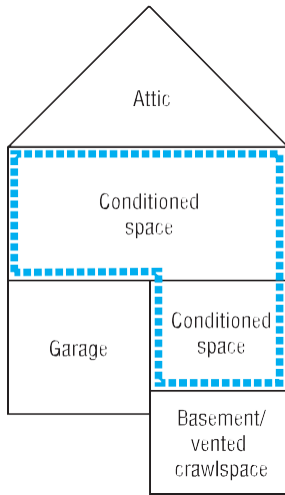

Example 2 – Alternate Compliance

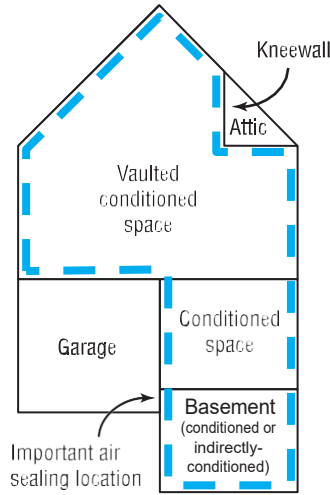

Example 3 – Alternate Compliance

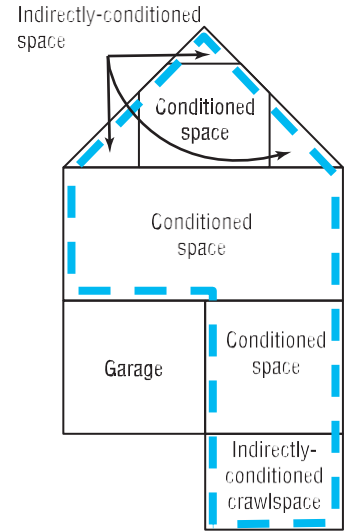

This is a conventional approach that likely locates all ductwork in unconditioned spaces.

Prescriptive R-values

- Flat ceiling: R-38
- Exterior walls: R-13
- Floor over garage and basement/crawl: R-19 (climate zones 3 & 4)
- Ductwork sealed with mastic and insulated to R-8 in attic, R-6 in basement/crawlspace
- Garage⁵, attic and basement/crawl are unconditioned spaces

If supply registers deliver conditioned air to basement, it is considered conditioned. With no supply air, it is considered an indirectly-conditioned space.

Example R-values¹

- Flat ceiling: R-38
- Kneewalls: R-18 (required)² (R-13+R-5, R-15+R-3, R-19 in 2x6)
- Vaulted ceiling: R-20 air-permeable insulation plus R-5 rigid foam board³
- Exterior walls: R-13
- Basement masonry walls: R-5
- Basement slab: R-0⁴
- Ductwork sealed with mastic and insulated to R-8 in attic, R-6 in basement
- Garage⁵ and attic are unconditioned spaces

The top conditioned floor functions as a vaulted ceiling with interior walls although it appears to have kneewalls and a flat ceiling. An advantage of this approach is that all upstairs ductwork is located inside the building envelope.

The crawlspace walls are insulated and do not contain vents. The crawlspace ground is covered with 100% plastic and functions as a “mini-basement.”

Example R-values¹

- Vaulted ceiling: R-20 air-impermeable foam insulation³
- Exterior walls: R-13 + R-5 sheathing
- Crawlspace walls: R-5
- Ductwork sealed with mastic and insulated to R-6
- Garage⁵ is unconditioned space

1 R-values shown are examples and not necessarily prescriptive code requirements. Refer to the Georgia Energy Code for specific prescriptive insulation requirements.

2 An attic kneewall is any vertical wall that separates conditioned space from an unconditioned attic. In Georgia, kneewalls must be insulated to R-18. A sealed attic-side air barrier (OSB, foil-faced sheathing, etc.) is required when using air permeable insulation.

3 Requires trade-off since prescriptive ceiling requirement is R-38, see roofline installed insulation options and section 806.5 of the 2012 IRC.

4 Slab insulation is not required in Georgia due to termite risk.

5 Although there is nothing to prevent the garage walls from being insulated, due to indoor air quality concerns, the garage should never be considered inside the building

Disclaimer:
This document was created by Southface and is intended solely to help graphically demonstrate the air leakage and insulation provisions of the 2015 IECC (2019 Georgia Energy Code). It does not cover all air sealing locations, materials or techniques. Other code provisions may be applicable as well.

Insulation Details for Ceilings with Attic spaces

Rafter and Truss

Standard Truss
 with tapered
 insulation depth

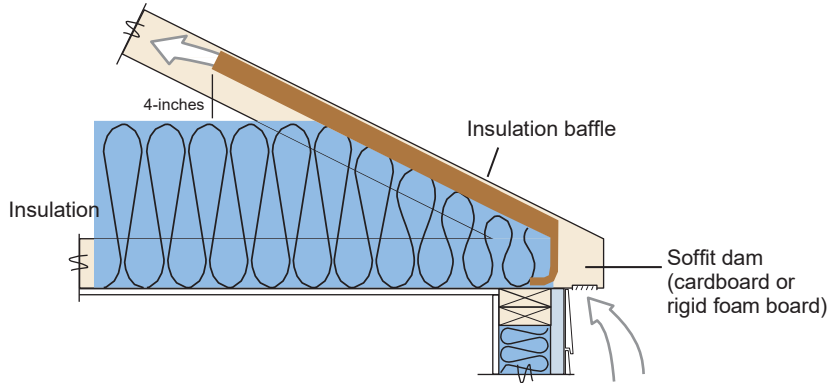

Note: Wind wash baffle and air-permeable insulation dam. For air permeable insulation in vented attics, baffles shall be installed adjacent to soffit and eave vents. A minimum of a 1-inch of space shall be provided between the insulation and the roof sheathing and at the location of the vent. The baffle shall extend over the top of the insulation inward until it is at least 4 inches vertically above the top of the insulation. Any solid material such as cardboard or thin insulating sheathing shall be permissible as the baffle.

Energy Truss
 with full height insulation
 (recommended)

NOTE:
 R-30 complete coverage
 is deemed equivalent to
 prescriptive R-38

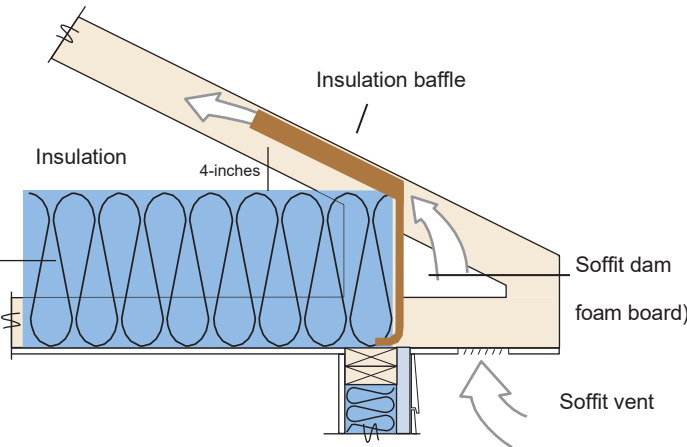

Standard rafter
 and top plate
 with tapered
 insulation depth

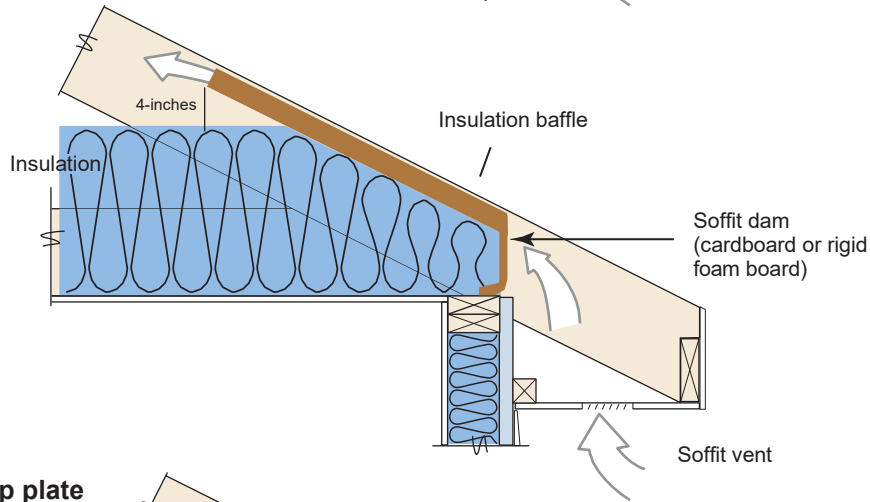

Rafter on raised top plate
 with full height insulation
 (recommended)

NOTE:
 R-30 complete coverage
 is deemed equivalent to
 prescriptive R-38

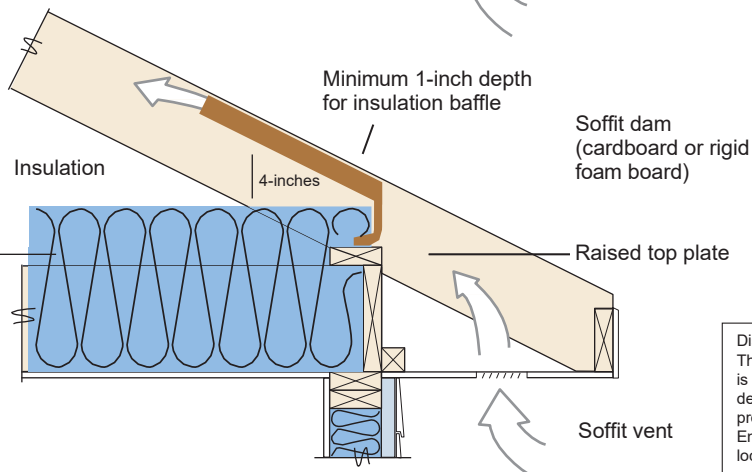

Disclaimer:
 This document was created by Southface and is intended solely to help graphically demonstrate the air leakage and insulation provisions of the 2015 IECC (2019 Georgia Energy Code). It does not cover all air sealing locations, materials or techniques. Other code provisions may be applicable as well.

Roofline Installed Insulation Options

Reference Table 402.1.1 and 402.1.6 in the Georgia Energy Code amendments to the 2015 IECC and Section 806.5 "unvented attic assemblies" in the Georgia Amendments to the 2012 IRC

Vaulted unvented attic – roofline air-impermeable insulation (e.g., spray foam insulation)

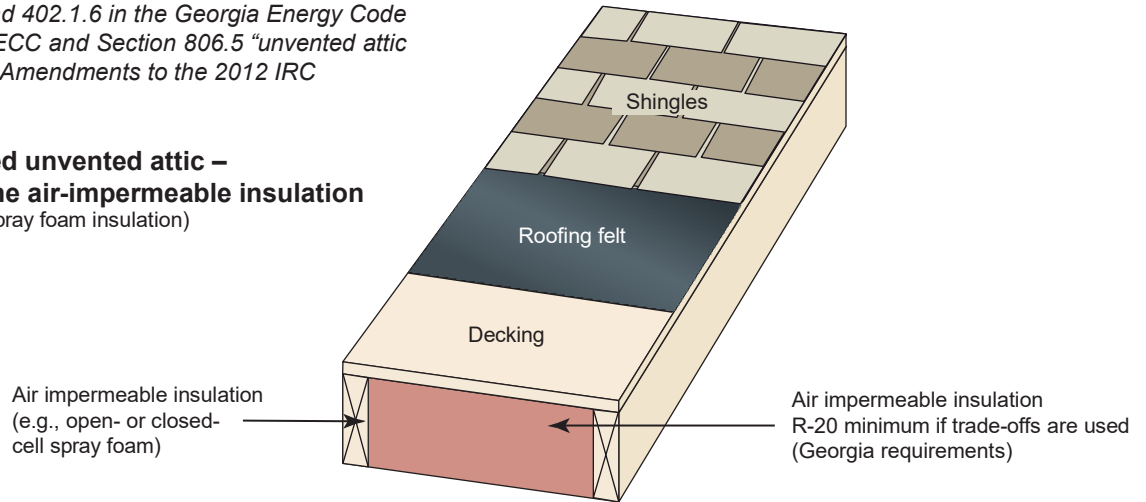

Vaulted unvented attic – roofline air-permeable insulation (e.g., fiberglass, cellulose insulation)

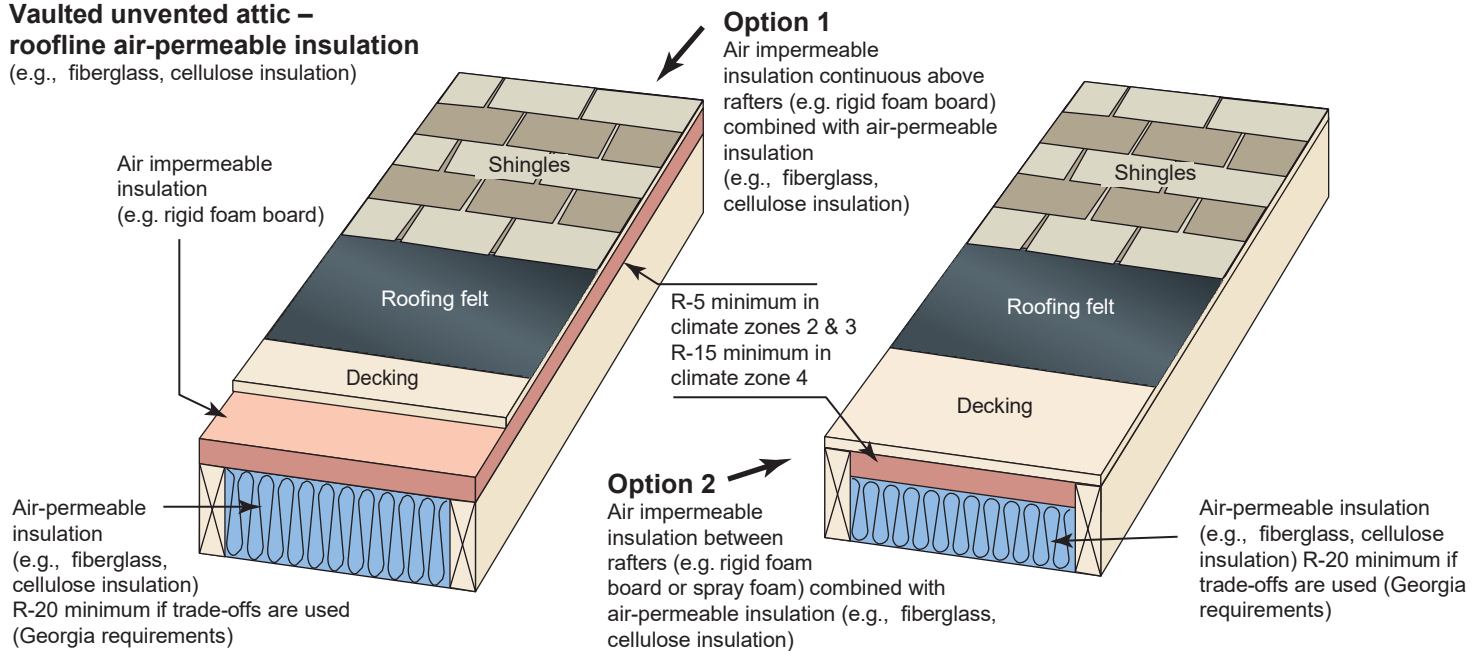

Cathedralized vented ceiling – roofline air-permeable insulation (e.g., fiberglass, cellulose insulation)

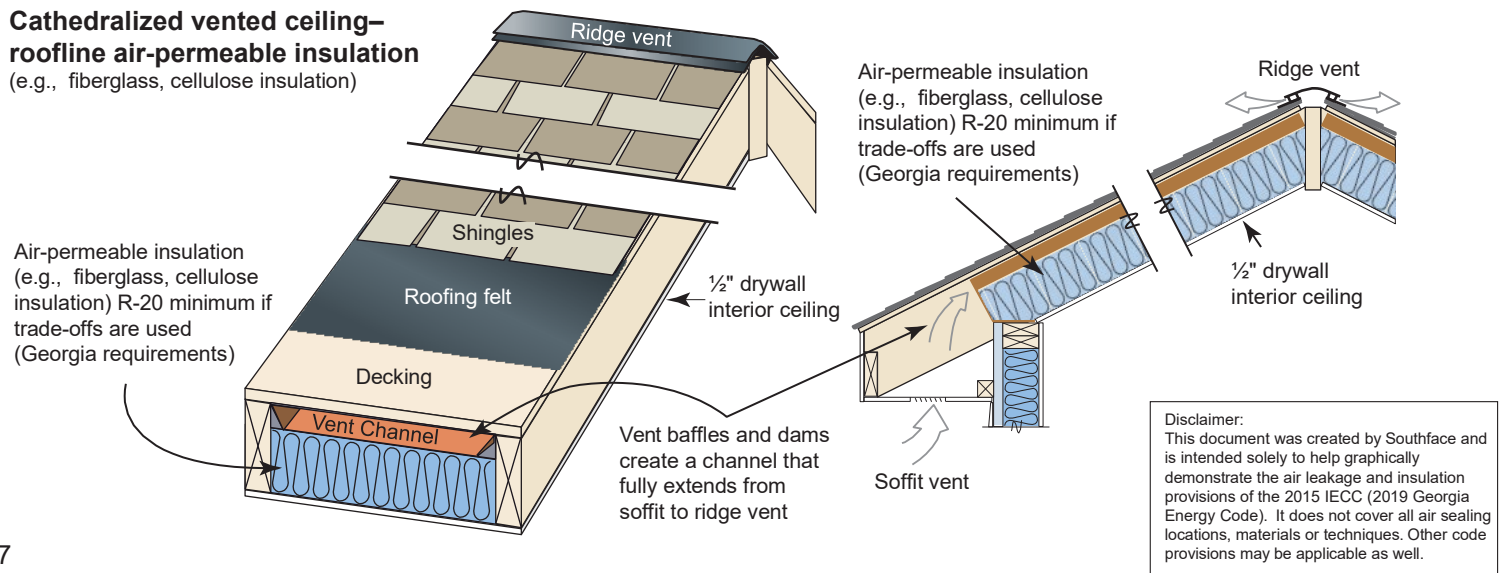

Disclaimer:
 This document was created by Southface and is intended solely to help graphically demonstrate the air leakage and insulation provisions of the 2015 IECC (2019 Georgia Energy Code). It does not cover all air sealing locations, materials or techniques. Other code provisions may be applicable as well.

Georgia Insulation Installation – *Passing Grade Details*

Wall and ceiling insulation that makes up portions of the building thermal envelope shall be installed to Passing Grade quality.

Two criteria affect installed insulation grading: **voids/gaps** (in which no insulation is present in a portion of the overall insulated surface) and **compression/incomplete fill** (in which the insulation does not fully fill out or extend to the desired depth).

Voids/Gaps

- Voids or gaps in the insulation are < 1% of overall component surface area (only occasional and very small gaps allowed for Passing Grade)

Compression/Incomplete Fill

- Compression/Incomplete Fill for both *air permeable insulation* (e.g., fiberglass, cellulose) and *air impermeable insulation* (e.g., spray polyurethane foam) must be less than 1 inch in depth or less than 30% of the intended depth, whichever is more stringent. The allowable area of compression/incomplete fill must be less than 2% of the overall insulated surface to achieve a Passing Grade.
- Any compression/incomplete fill with a **depth** greater than the above specifications (up to 1" or 30% of the intended depth, whichever is more stringent) shall not achieve a Passing Grade.

Additional Wall Insulation Requirements

- All vertical air permeable insulation shall be installed in substantial contact with an air barrier on all six (6) sides.
Exception: Unfinished basements, rim/band joist cavity insulation and fireplaces (insulation shall be restrained to stay in place).
For unfinished basements, air permeable insulation and associated framing in a framed cavity wall shall be installed less than ¼" from the basement wall surface.
- Attic knee wall details – Attic knee walls shall be insulated to a total R-value of at least R-18 through any combination of cavity and continuous insulation. Air permeable insulation shall be installed with a fully sealed attic-side air barrier (e.g., OSB with seams caulked, rigid insulation with joints taped, etc.). Attic knee walls with air impermeable insulation shall not require an additional attic-side air barrier.

Underfloor insulation that makes up portions of the building thermal envelope shall be installed to Passing Grade quality.

Two criteria affect installed insulation grading: **voids/ gaps** (in which no insulation is present in a portion of the overall insulated surface) and **compression/incomplete fill** (in which the insulation does not fully fill out or extend to the desired depth).

Voids/Gaps

- Voids or gaps in the insulation are minimal for Passing Grade (< 2% of overall component surface area)

Compression/Incomplete Fill

- Compression/Incomplete Fill for both *air permeable insulation* (e.g., fiberglass, cellulose) and *air impermeable insulation* (e.g., spray polyurethane foam) must be less than 1 inch in depth or less than 30% of the intended depth, whichever is more stringent. The allowable area of compression/incomplete fill must be less than 10% of the overall insulated surface to achieve a Passing Grade.
- Any compression/incomplete fill with a **depth** greater than the above specifications (up to 1" or 30% of the intended depth, whichever is more stringent) shall not achieve a Passing Grade.
- Air-permeable underfloor insulation shall be permanently installed against the subfloor decking. Adequate insulation supports (e.g., wire staves) for air permeable insulation shall be installed at least every 18-24".
Exception: The floor framing-cavity insulation shall be permitted to be in contact with the topside of sheathing or continuous insulation installed on the bottom side of floor framing where combined with insulation that meets or exceeds the minimum wood frame wall R-value and that extends from the bottom to the top of all perimeter floor framing members.

Disclaimer: This document was created by Southface and is intended solely to help graphically demonstrate the air leakage and insulation provisions of the 2015 IECC (2019 Georgia Energy Code). It does not cover all air sealing locations, materials or techniques. Other code provisions may be applicable as well.

Wall Insulation key points

Voids / Gaps

Passing Grade 

Insulation is notched and completely surrounds electrical box

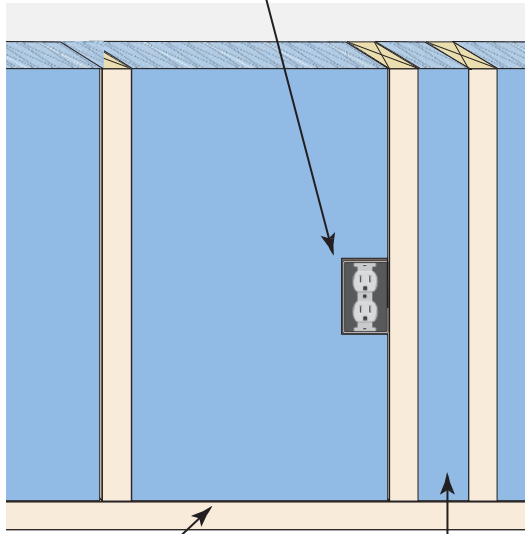

Insulation fully fills cavity at top and bottom

Narrow cavity fully insulated

Unacceptable Installation 

Incomplete insulation coverage around electrical box

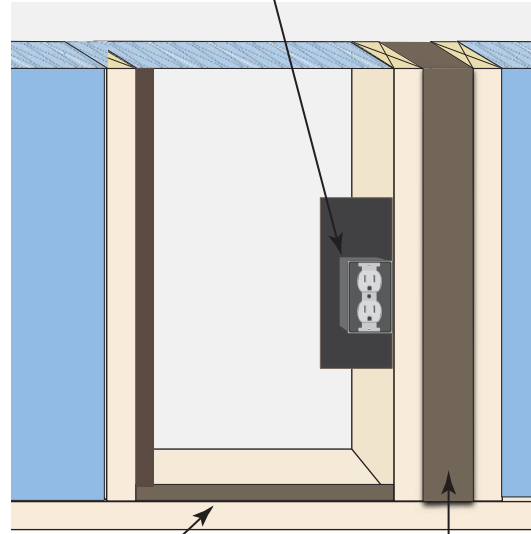

Insulation does not extend to bottom of cavity

Narrow cavity not insulated

Compression / Incomplete Fill

Passing Grade 

Insulation is slit around electrical wire

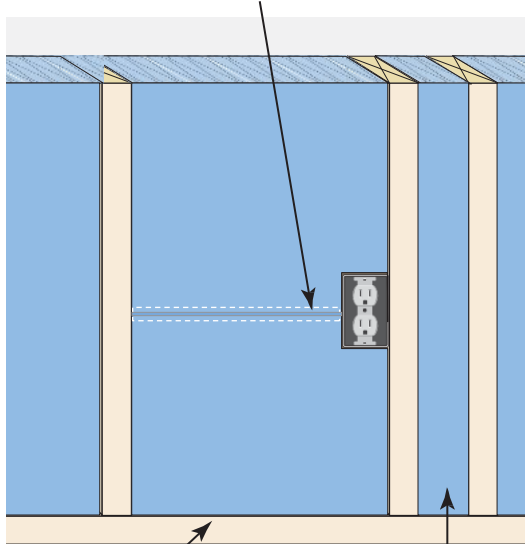

Insulation extends from front to back and fully fills entire cavity

Proper width insulation fully fills narrow cavity

Unacceptable Installation 

Insulation is compressed behind electrical wire

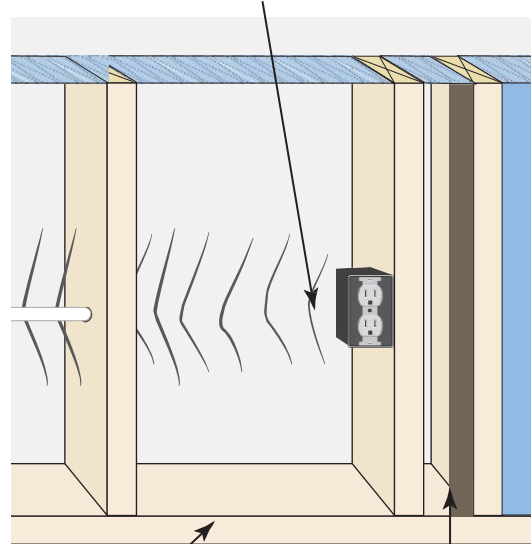

Insulation does not fully fill entire cavity

Improper width insulation is compressed into narrow cavity

Disclaimer:
This document was created by Southface and is intended solely to help graphically demonstrate the air leakage and insulation provisions of the 2015 IECC (2019 Georgia Energy Code). It does not cover all air sealing locations, materials or techniques. Other code provisions may be applicable as well.

Ceiling Insulation key points

Passing Grade 

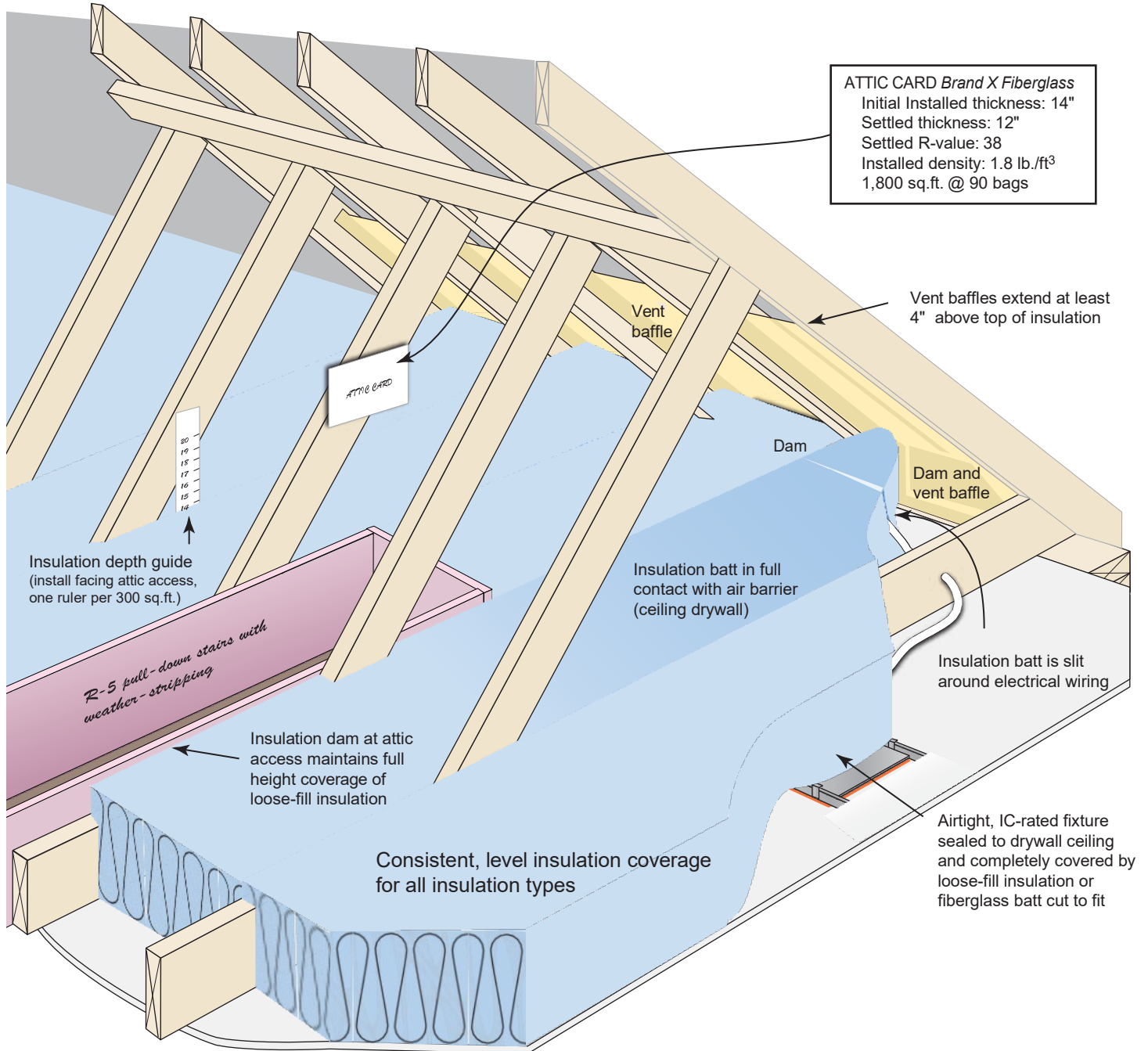

Disclaimer:
This document was created by Southface and is intended solely to help graphically demonstrate the air leakage and insulation provisions of the 2015 IECC (2019 Georgia Energy Code). It does not cover all air sealing locations, materials or techniques. Other code provisions may be applicable as well.

Ceiling Insulation key points

Unacceptable installation 

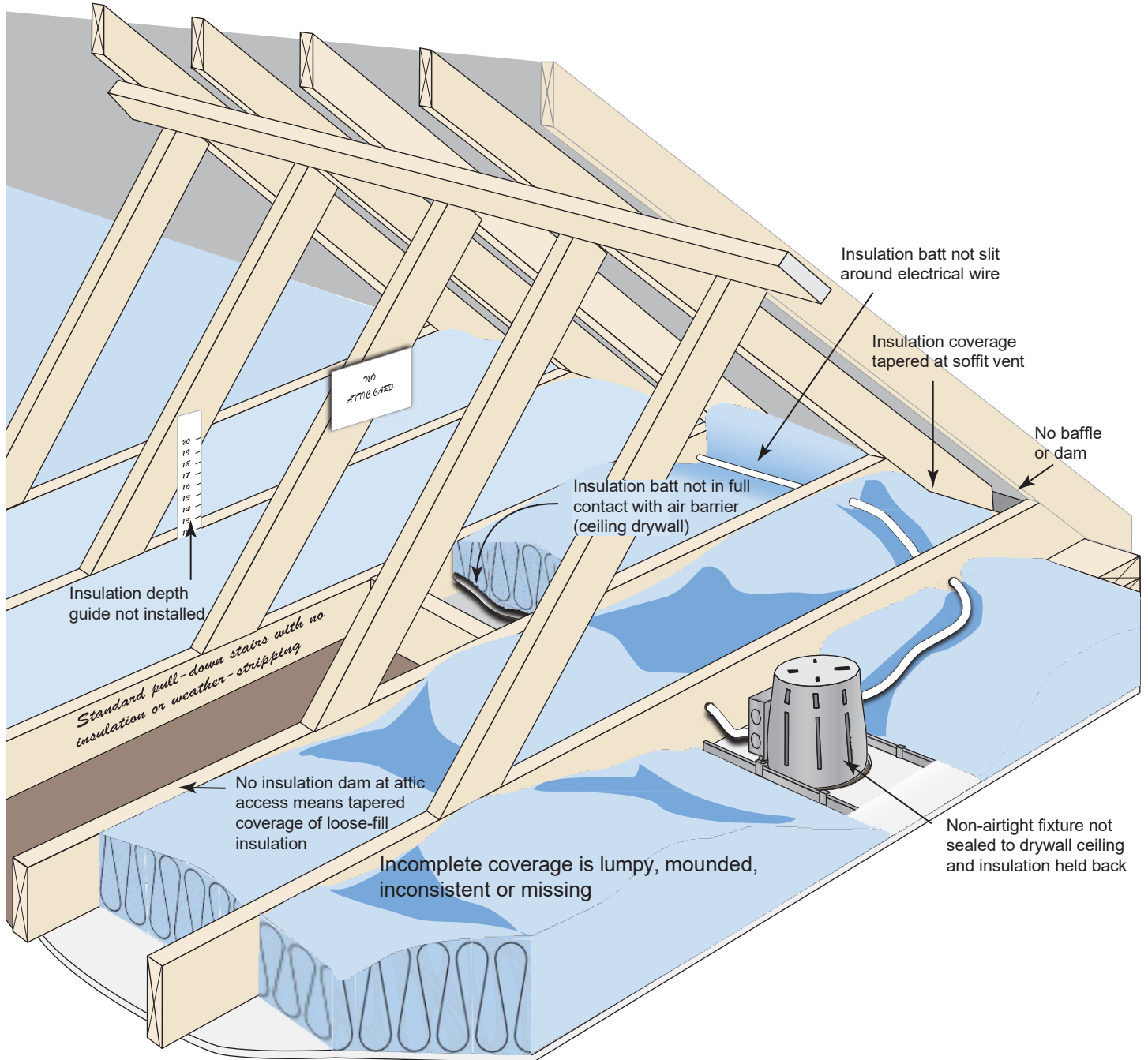

Disclaimer:
This document was created by Southface and is intended solely to help graphically demonstrate the air leakage and insulation provisions of the 2015 IECC (2019 Georgia Energy Code). It does not cover all air sealing locations, materials or techniques. Other code provisions may be applicable as well.

Floor Insulation key points

Passing Grade

Installed insulation is in complete contact with air barrier (subfloor)

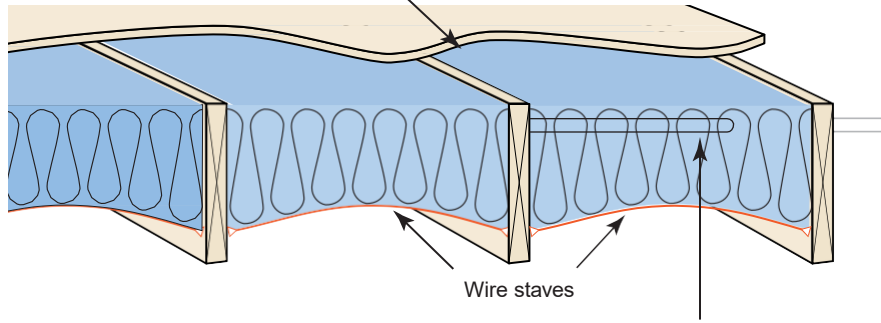

Insulation coverage is complete

Insulation is slit around plumbing and wiring and securely fastened with minimal compression

Unacceptable Installation

Insulation is not installed in complete contact with air barrier (subfloor)

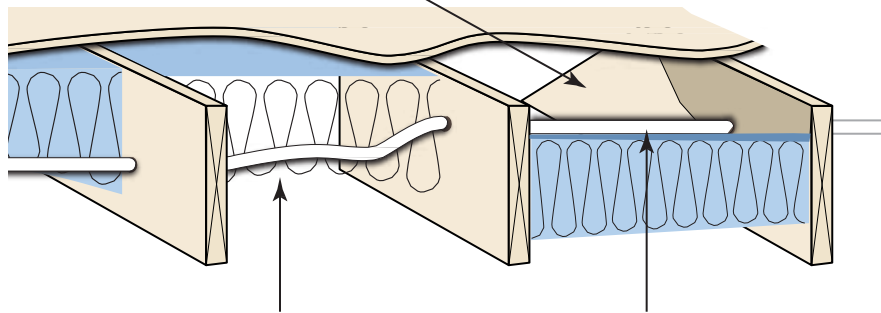

Insulation coverage is incomplete due to obstructions (plumbing, electrical, ductwork, etc.)

Insulation is compressed around plumbing and wiring and is not securely fastened

Disclaimer:
This document was created by Southface and is intended solely to help graphically demonstrate the air leakage and insulation provisions of the 2015 IECC (2019 Georgia Energy Code). It does not cover all air sealing locations, materials or techniques. Other code provisions may be applicable as well.